



2501 Ludelle Street
Fort Worth, Texas 76105
817-244-6212 Phone • 817-244-4024 Fax
888-350-6588 Sales • 800-423-9696 Tech
E-mail: painless@painlessperformance.com
Web: www.painlessperformance.com

EMISSIONS KIT FOR '96-'99 VORTEC ENGINES Part #60320, 60321

This kit includes the wiring for the rear oxygen sensors and the fuel tank pressure sensor.

Disconnect the battery from the vehicle at this time.

NOTE: In 1997 5.0 and 5.7 liter trucks did not have a fuel tank pressure sensor. The 4.3 liter did have a fuel tank pressure sensor. So, depending on the engine you are utilizing you may or may not need the fuel tank pressure sensor wires included in this kit. For this reason, the three wires orange/black, green and gray are provided as a separate pigtail. If using the fuel tank pressure sensor, route the wires as stated below. Do not install these three wires if you are not using the fuel tank pressure sensor.

STEP 1 - ROUTING THE WIRES

Begin by locating the red wire (with a ring terminal), the tan/white, purple/white, pink and black wires that are tie wrapped together, also the tan, purple, pink and black wires that are tie wrapped together, as well as the orange/black, green and gray wires that are tie wrapped together, and a black wire (with a ring terminal). Pass these wires through the Fuel Injection Harness grommet, from the passenger compartment into the engine compartment. These wires are terminated with the correct terminals and wire seals to fit the connectors supplied in the bag kit.

NOTE: DO NOT INSTALL CONNECTOR HOUSING ON THESE WIRES UNTIL AFTER THEY HAVE BEEN PASSED THROUGH THE GROMMET IN THE FIREWALL.

CAUTION: BE CAREFUL ROUTING THE WIRES THROUGH THE FIREWALL TO AVOID DAMAGING THE TERMINALS ON THE ENDS OF THE WIRES.

STEP 2 - INSTALLATION OF CONNECTORS IN THE ENGINE COMPARTMENT

In the bag kit you will find three connector housings and three Terminal Position Assurance locks (TPA). Take one of the four-way connector housings and insert the tan/white, purple/white, pink and black wires into the A, B, C, and D cavities until the terminal locking tang engages, as shown in **Illustration 1**. Repeat this step for the tan, purple, pink and black wires using the remaining four-way connector. The connector with the striped wires will be connected to the left oxygen sensor and the other to the right.

NOTE: THE TERMINAL WILL ONLY FIT ONE WAY INTO THE CONNECTOR. DO NOT TRY TO FORCE THE TERMINAL.

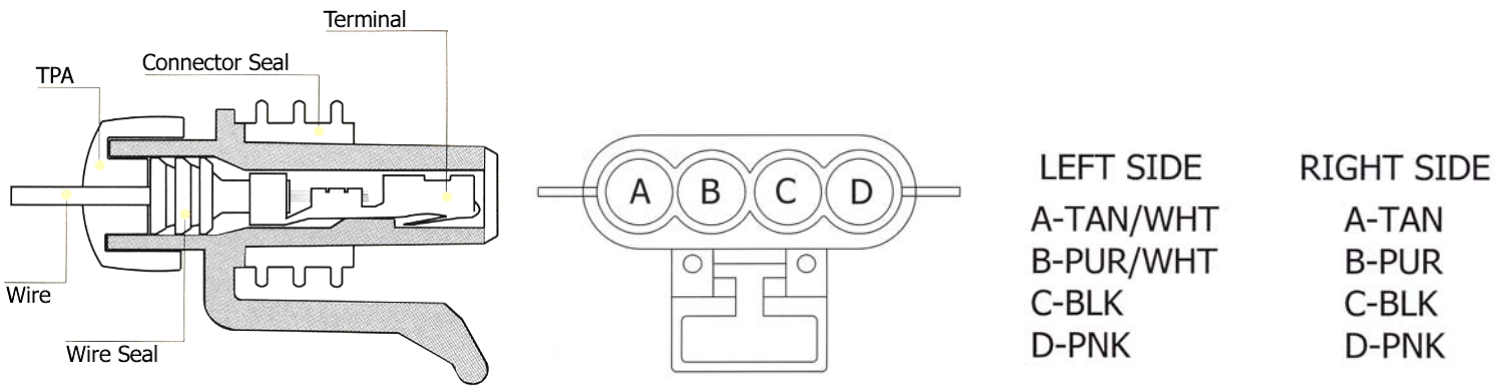

ILLUSTRATION 1 Rear Oxygen Sensor Connector pin out

Be sure to use the black TPA on the connector housings after the wires have been inserted into the proper cavities. These connectors can now be routed and plugged into the rear oxygen sensors located behind or rear of the catalytic converter.

Take the black three-way connector housing and insert the orange/black wire into the A cavity, the green wire into the B cavity and the gray wire into the C cavity until the locking tangs engage, as shown in **Illustration 2**.

NOTE: THE TERMINAL WILL ONLY FIT ONE WAY INTO THE CONNECTOR. DO NOT TRY TO FORCE THE TERMINAL.

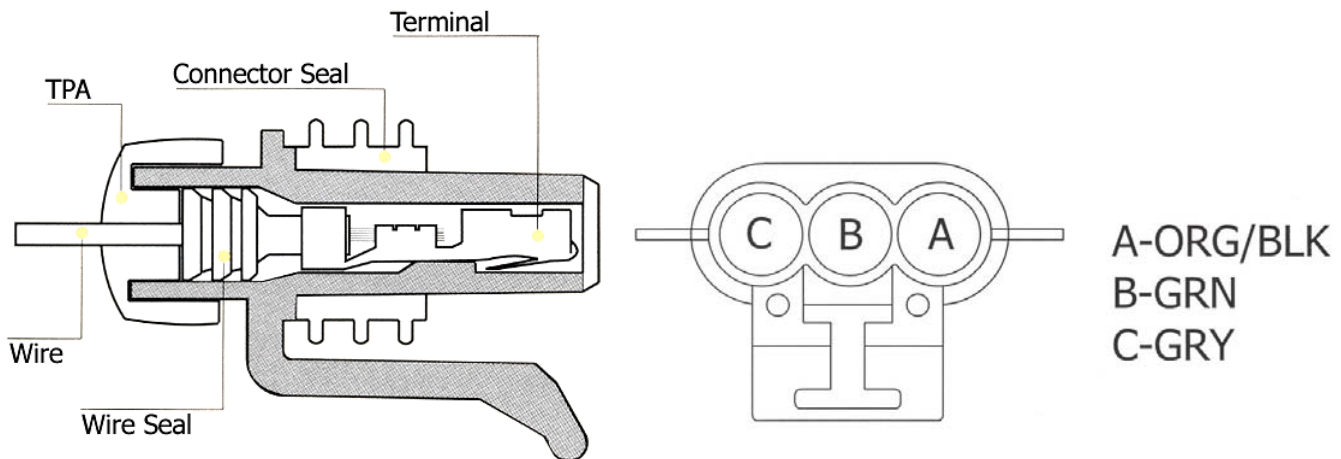

ILLUSTRATION 2 Fuel pressure sensor connector pin out

Be sure to install the white TPA on the connector housing after the wires have been inserted into the proper cavities. This connector can now be routed and plugged into the fuel tank pressure sensor located on fuel tank pump assembly.

Connect the red wire with the ring terminal to the starter solenoid "BATT" terminal.

STEP 3 - UNPLUGGING THE COMPUTER

CAUTION: REMOVING THE COMPUTER CONNECTORS FROM THE COMPUTER WHILE THE IGNITION IS ON WILL DAMAGE THE COMPUTER!

First, make sure that the battery is disconnected. Next, unplug the blue, red, and the gray/clear computer connectors by depressing the retaining tabs and pulling straight out and away from the computer. **BE CAREFUL NOT TO DAMAGE THE COMPUTER PINS!** Remove the red and blue secondary locks from the computer connectors by releasing the retaining clips and pulling them out and away from the connector assemblies. On the wire side of the connectors release the locking tabs using a pocket screw driver or small pick, allowing the two halves to unfold exposing the wires.

STEP 4 - CONNECTING THE REAR OXYGEN SENSORS AT THE COMPUTER

Using **Illustration 3** for reference, look on the rear side of the blue 32 pin computer connector housing for the cavity marked "24". Once you have located the "24" cavity, insert the tan wire terminal into this cavity, pushing in until the locking tang engages. Next, insert the tan/white wire terminal into the "26" cavity. Next locate the "20" and "22" cavities, insert the purple wire terminal into the "20" cavity and the purple/white wire terminal into the "22" cavity. This will complete all of the oxygen sensor wires.

WIRE SIDE VIEW OF COMPUTER CONNECTORS

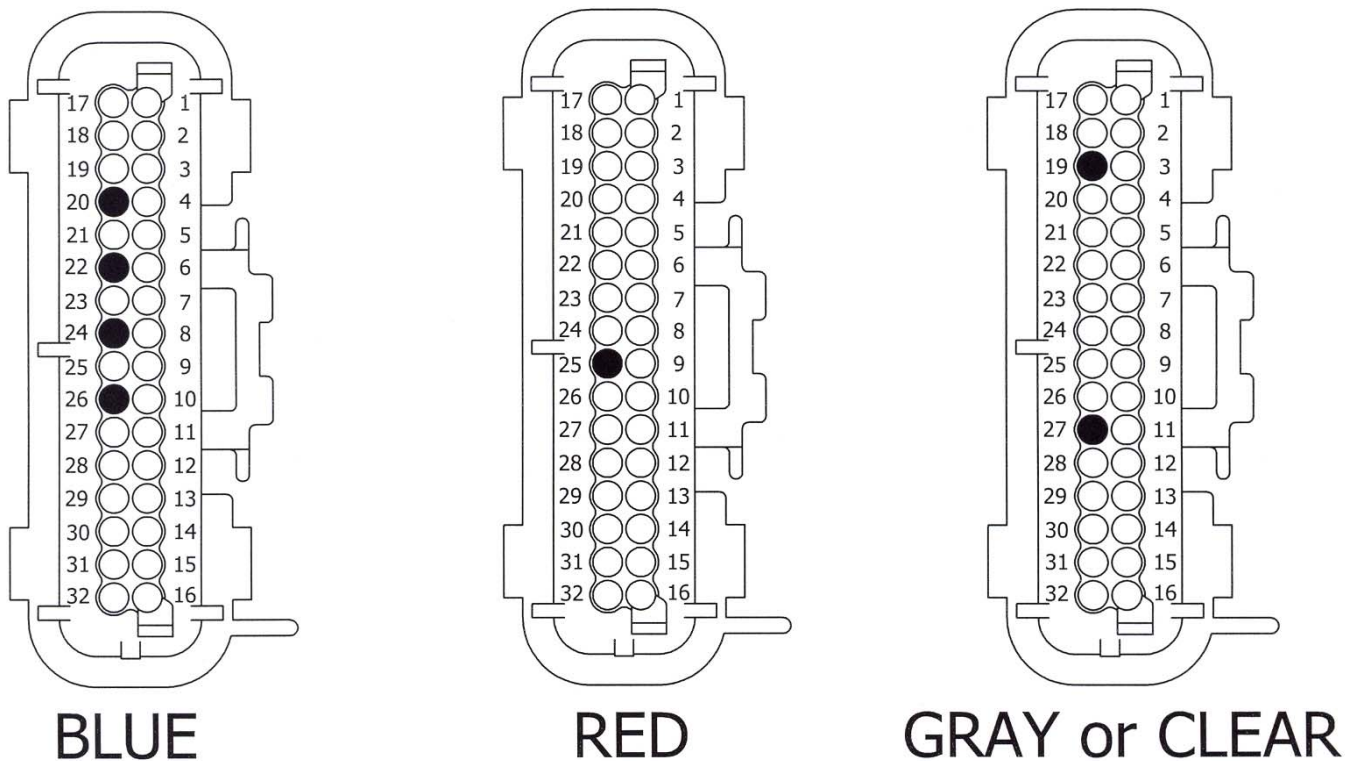

ILLUSTRATION 3 Computer connector pin out

STEP 5 - CONNECTING THE FUEL TANK PRESSURE SENSOR AT THE COMPUTER

On the red 32 pin connector, locate the "25" cavity, and insert the green wire terminal until the locking tang engages. Next, on the gray/clear 32 pin connector locate the "19" cavity. There is a black wire already protruding from this cavity. You must splice the orange/black fuel tank pressure sensor wire onto this wire. There is a butt splice connector and heat shrink provided in the parts bag. On the same gray/clear 32 pin computer connector locate the "27" cavity. You must splice the gray fuel tank pressure sensor wire onto this wire. There is a butt splice connector and heat shrink provided in the parts bag. This completes all of the fuel tank pressure sensor wires.

NOTE: It is very important that these splices are done with good crimps on the butt connectors. The black wire is a shared sensor ground and the gray wire is a shared five volt, sensor reference.

STEP 6 - REPLACING THE COMPUTER CONNECTORS AT THE COMPUTER

Replace the red, blue, and gray/clear secondary locks on the three computer connectors. Be careful to line up the "fingers" on the locks with the connector openings. Once you have the secondary locks in place, reinstall the computer connectors into the computer. The relays and fuse holders should be positioned near the computer of the Painless Fuel Injection Harness. Screws and mounting hardware for securing the relays and fuse holders is included in the bag kit.

CAUTION: USE CARE WHEN RE-INSTALLING THE COMPUTER CONNECTOR, TO AVOID DAMAGING THE COMPUTER PINS.

STEP 7 – POWER AND GROUND

Take the pink wire located near the relays and route it to a switched 12 volt source, this 12 volt source can come from the painless fuse block or the factory fuse block. NOTE: THE PINK WIRE IS ONLY A RELAY ACTIVATION THAT WILL DRAW LESS THAN A 1 AMP LOAD. Terminals are provided to piggy back this wire onto one of the vehicles existing fuses. Locate the black wire with a ring terminal and use one of the screws from the bag kit to ground it to the chassis.

NOTE: DOUBLE CHECK ALL ROUTING, MAKING SURE THAT THERE IS ENOUGH SLACK TO ALLOW FOR ANY ENGINE MOVEMENT. REINSTALL ANY GROMMETS OR OTHER PARTS TAKEN OFF. START AND DRIVE THE VEHICLE FOR AT LEAST THIRTY MINUTES, THEN CHECK FOR ANY TROUBLE CODES STORED IN THE COMPUTER. PAINLESS WIRING OFFERS A TECHNICAL ASSISTANCE LINE TO ANSWER ANY QUESTIONS YOU MAY HAVE. THE NUMBER IS (800)423-9696. PHONES ARE ANSWERED MONDAY THROUGH FRIDAY FROM 8 AM TO 5 PM CENTRAL TIME, NOT INCLUDING HOLIDAYS. PLEASE LEAVE A MESSAGE IF YOU ARE UNABLE TO REACH US AND WE WILL RETURN YOU'RE CALL AS SOON AS POSSIBLE.

Painless Performance Limited Warranty and Return Policy

Chassis harnesses and fuel injection harnesses are covered under a lifetime warranty. All other products manufactured and/or sold by Painless Performance are warranted to the original purchaser to be free from defects in material and workmanship under normal use. Painless Performance will repair or replace defective products without charge during the first 12 months from the purchase date. No products will be considered for warranty without a copy of the purchase receipt showing the sellers name, address and date of purchase. You must return the product to the dealer you purchased it from to initiate warranty procedures.

Copyright © 2007 by Perfect Performance Products, LLC