



Perma Industries Incorporated
400 South Rockefeller Avenue • Ontario, CA 91761-8144 USA
Tel 909.390.1550 • Fax 909.390.1551
www.perma-cool.com

Installation Instructions

This guide covers the following:

Oil Filter Mount

Congratulations, you have made a wise decision. Thank you for purchasing our product.

Single or Dual Oil Filter Mount

IMPORTANT! READ ALL INSTRUCTIONS BEFORE BEGINNING INSTALLATION.

Thank you for your purchasing our product(s). Install filter nipple into mount; Thread first, knurl last (see illustration). Tighten securely. Install hose fittings in the filter mount ports. If the fittings are tapered pipe (NPT), seal the threads with Teflon[®] tape or appropriate sealer. If the fittings are AN/SAE, **DO NOT** use any type of sealer on the threads. **MAXIMUM TORQUE** on the fittings is 28 ft.lbs. (38Nm). **DO NOT OVERTIGHTEN!** If the filter mount is a dual filter mount, install plugs in the ports not used.

Locate a convenient location to mount the oil filter mount. Some suggested locations are on the vehicle frame, fenders, or firewall. Attach the filter mount with sheet metal screws or nuts and bolts, available at any hardware store.

Apply a thin film of fresh oil to a new oil filter, and install on the filter mount. Tighten by hand 1/4 to 1/2 turn past O-ring contact with sealing surface.

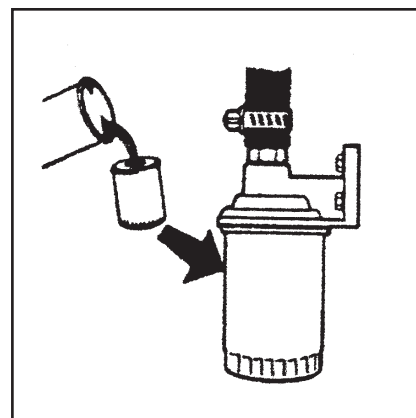
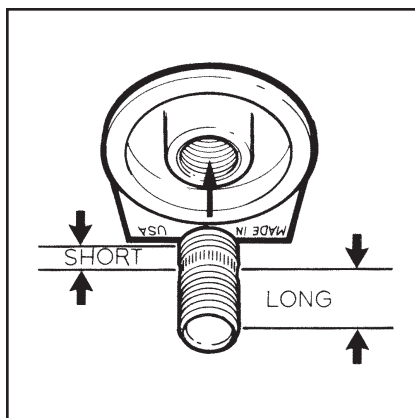
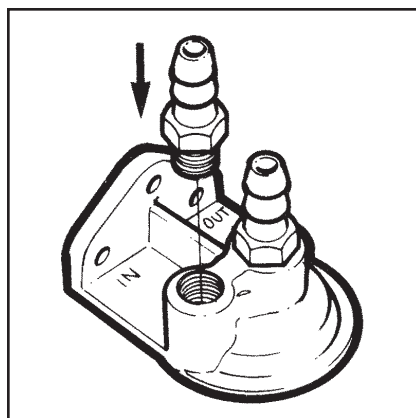

For additional accessories or replacement parts
visit www.perma-cool.com