

## FORD SUPER DUTY SUSPENSION SYSTEM by RANCHO INDUSTRIES

Requires the following parts (sold separately) for a complete installation:

RS44054 (2)...Front Leaf Spring	RS9264 (2)...Front Shock	RS6553...Bracket Kit
RS44154 (2)...Rear Leaf Spring	RS9012 (2)...Rear Shock	RS6742 Dual Shock Kit (Optional)

**READ ALL INSTRUCTIONS THOROUGHLY FROM START TO FINISH BEFORE BEGINNING INSTALLATION**

### **IMPORTANT NOTES!**

A. Bracket kit RS6542 fits 1999 model year vehicles manufactured before 3/99. Bracket kit RS6552 fits 1999 model year vehicles manufactured after 3/99 and equipped with pitman arm "YC35-3590-AA". Use bracket kit RS6553 for 2000 model year vehicles.

B. Before installing this system, have the vehicle's alignment and frame checked by a certified technician. The alignment must be within factory specifications and the frame must be sound (no cracks, damage, or corrosion).

C. Do not install a body lift kit with Rancho's suspension system or interchange parts from this system with components from another manufacturer. Use the appropriate Rancho shock absorbers and leaf springs. Contact your local Rancho representative for the correct applications.

D. Compare the contents of this system with the parts list in these instructions. If any parts are missing, including fasteners, contact the Rancho Technical Department at 1-800-574-6257. Each hardware kit in this system contains fasteners of high strength and specific size. Do not substitute a fastener of lesser strength or mix one hardware kit with another.

E. Apply **THREAD LOCKING COMPOUND** to all bolts during installation. One drop on the exposed threads of each bolt before installing the nut is sufficient to provide an adequate bond. **CAUTION:** Thread locking compound may irritate sensitive skin. Read warning label on container before use.

F. Install all nuts and bolts with a flat washer. When both SAE (small OD) and USS (large OD) washers are used in a fastener assembly, place the USS washer against the slotted hole and the SAE washer against the round hole.

G. Unless otherwise specified, tighten all bolts to the standard torque specifications listed at the end of the note's section. Do not use an impact wrench to tighten any of these bolts. They tend to over tighten smaller bolts and under tighten larger bolts. **USE A TORQUE WRENCH!**

H. Rancho parts come with a protective coating. Do not chrome, cadmium, or zinc plate any of the components in this system. If you wish to change the appearance of components enamel paint can be applied over the original coating.

I. This suspension system is a "bolt on assembly". Do not weld any of these components to the vehicle. If any component breaks or bends, contact your local dealer or Rancho for replacement parts.

J. Some of the service procedures require the use of special tools designed for specific procedures. The following tools and supplies are recommended for proper installation of this system. ■

- Ford Service Manual
- Steering Arm Puller T64P-3590-F
- Torque Wrench (250 FT-LB capacity)
- 1/2" Drive Ratchet and Sockets
- 1/2" Drive Breaker Bar
- Combination Wrenches
- Heavy Duty Jack Stands
- Hydraulic Floor Jack
- Wheel Chocks (wooden blocks)
- Large "C" Clamps and or Bench Vise
- Hammer
- Wire Brush (to clean bracket mounting surfaces)
- Tape Measure
- Brake fluid
- Safety Glasses**--Wear safety glasses at all times

K. It is extremely important to replace torsion bars, CV flanges, and front drive shaft/pinion relationships as original. Be sure to mark left/right, front/rear, and indexing of mating parts before disassembly. A paint marker or light colored nail polish is handy for this.

L. Suspension components that use rubber or urethane bushings should be tightened with the vehicle at normal ride height. This will prevent premature failure of the bushing and maintain ride comfort.

M. The required installation time for this system is approximately 6 hours. Check off the box (  ) at the beginning of each step when you finish it. Then when you stop during the installation, it will be easier to find where you need to continue from.

N. Important information for the end user is contained in the consumer information pack. If you are installing this suspension system for someone else, display the information pack by hanging it from the rear view mirror.

O. Thank you for purchasing the best suspension system available. For the best installed system, follow these instructions. If you do not have the tools or are unsure of your abilities, have this kit installed by a certified technician. **RANCHO SUSPENSION IS NOT RESPONSIBLE FOR DAMAGE OR FAILURE RESULTING FROM AN IMPROPER OR MODIFIED INSTALLATION.**

STANDARD BOLT TORQUE & IDENTIFICATION						
INCH SYSTEM			METRIC SYSTEM			
Bolt Size	Grade 5	Grade 8	Bolt Size	Class 9.8	Class 10.9	Class 12.9
5/16	15 ft. lbs.	20 ft. lbs.	M6	5 ft. lbs.	9 ft. lbs.	12 ft. lbs.
3/8	30 ft. lbs.	35 ft. lbs.	M8	18 ft. lbs.	23 ft. lbs.	27 ft. lbs.
7/16	45 ft. lbs.	60 ft. lbs.	M10	32 ft. lbs.	45 ft. lbs.	50 ft. lbs.
1/2	65 ft. lbs.	90 ft. lbs.	M12	55 ft. lbs.	75 ft. lbs.	90 ft. lbs.
9/16	95 ft. lbs.	130 ft. lbs.	M14	85 ft. lbs.	120 ft. lbs.	145 ft. lbs.
5/8	135 ft. lbs.	175 ft. lbs.	M16	130 ft. lbs.	165 ft. lbs.	210 ft. lbs.
3/4	185 ft. lbs.	280 ft. lbs.	M18	170 ft. lbs.	240 ft. lbs.	290 ft. lbs.

<b>1/2-13x1.75 HHCS</b> D T L X G = Grade Marking (bolt strength) D = Nominal Diameter (inches) T = Thread Pitch (threads per inch)	<b>Grade 5</b> <b>Grade 8</b> L = Length (inches) X = Description (hex head cap screw)	<b>M12-1.25x50 HHCS</b> D T L X P = Property Class (bolt strength) D = Nominal Diameter (millimeters) T = Thread Pitch (thread width, mm)	<b>-10.9</b> L = Length (millimeters) X = Description (hex head cap screw)

### RS6553 PARTS LIST

P/N	DESCRIPTION	QTY.	P/N	DESCRIPTION	QTY.
P01013	Sleeve	6		3/8 Lock Washer	6
1403	Bump Stop, Front	2		3/8 SAE Washer	4
170083	Brake Hose, Right	1	860086	Brake Hose Gasket Kit	1
170084	Brake Hose, Left	1		Copper Gasket	4
176093	Trackbar Drop Bracket	1	860150	Trackbar Hardware Kit	1
1900-12	Tie Wrap Kit	1		1/2-13 x 3.5 HHCS	1
	Tie Wrap	10		1/2-13 Nyloc Nut	1
740018	U-bolt	4		1/2 SAE Washer	2
7764	Pitman Arm	1		1/8 x 1.75 Cotter Pin	1
8103	U-bolt Hardware Kit	1		M14-2.00 Stover Nut	1
	5/8 SAE Washer	8		14mm Washer	1
	5/8-18 Nyloc Nut	8		.5cc Thread Lock	3
8105	Bump Stop Hardware Kit	1	88153	Installation Instruction	1
	3/8-24 x 1.0 HHCS	4	94140	Consumer Information Pack	1
	3/8-24 Nut	6			

## FRONT SUSPENSION

### VEHICLE PREPARATION & SHOCK REMOVAL

- 1) ✓ Park the vehicle on a level surface. Set the parking brake and chock rear wheels.
- 2) ✓ Disconnect the sway bar end links from the frame rail brackets. See illustration 1. Loosen the bolts holding the sway bar to the axle bracket.

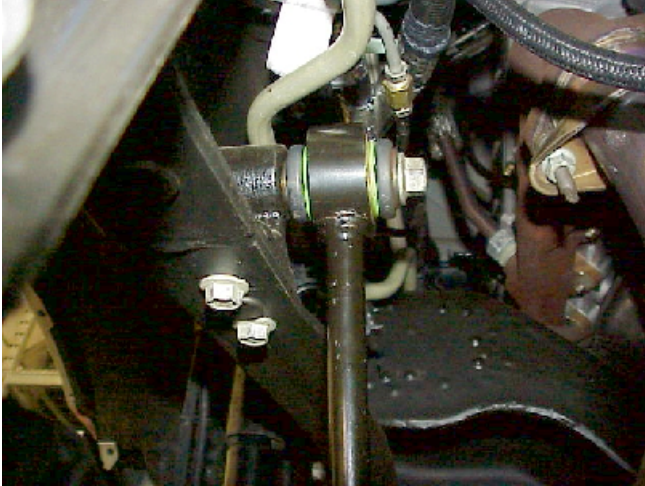

Illustration 1

- 3) ✓ Disconnect the trackbar from the driver side frame bracket. See illustration 2.

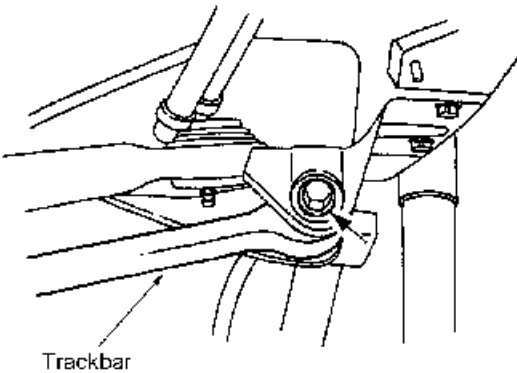

Illustration 2

- 4) ✓ Raise the front of the vehicle and support the frame with jackstands. Remove the front wheels and set them aside.
- 5) ✓ Remove the nut and bolt from the shock absorber lower mount.

- 6) ✓ Remove the upper mounting nut and pull the shock away from the mounting stud.
- 7) ✓ Repeat shock removal for the other side. Do Not reuse original equipment shock absorbers.

### TRACKBAR BRACKET & PITMAN ARM REPLACEMENT

- 1) ✓ Remove the two mounting bolts holding the trackbar bracket to the driver side frame rail. See illustration 3. Remove the nut and bolt attaching the bracket to the crossmember. Remove the trackbar bracket.

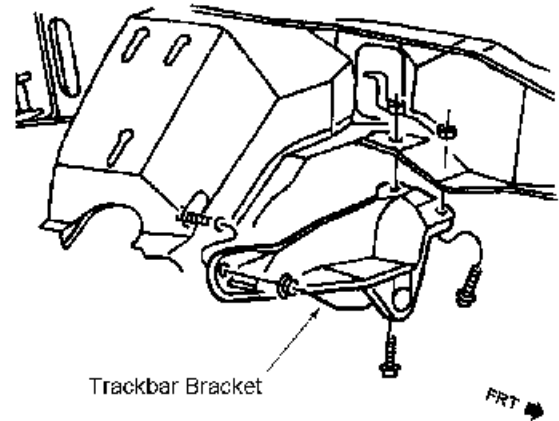

Illustration 3

- 2) ✓ Center the steering wheel. Remove the cotter pin and castellated nut from the drag link ball stud at the pitman arm.
- 3) ✓ Using steering arm puller T64P-3590-F, separate the pitman arm from the drag link. See illustration 4.

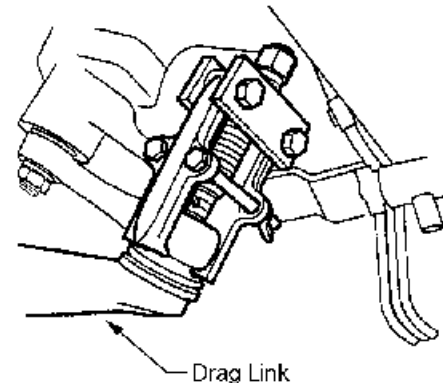

Illustration 4

- 4) ✓ Remove the nut and lock washer from the steering gear sector shaft. Remove the pitman arm using steering arm puller T64P-3590-F.
- 5) ✓ Install new pitman arm RS7730 or RS7764 on the sector shaft in the same position as the original arm. See illustration 5. Apply thread lock and tighten the sector shaft nut to 200 ft.-lbs.

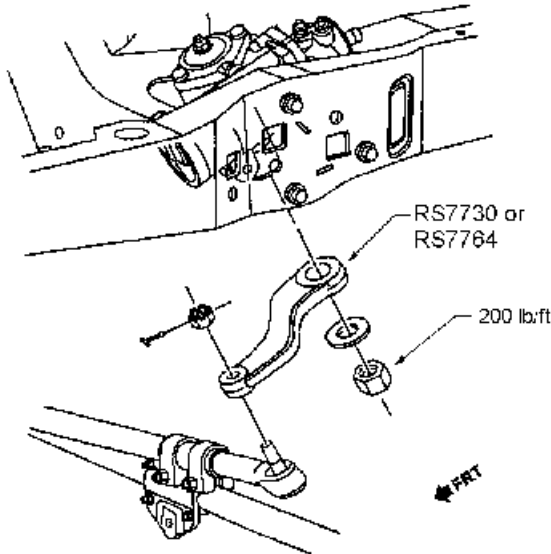

Illustration 5

- 6) ✓ Attach the drag link to the new pitman arm. Install the castellated nut and a new cotter pin.
- 7) ✓ Attach new trackbar bracket RS176079 or RS176093 to the frame with the original bolts and to the crossmember with the 1/2" hardware from kit RS860150.

### BRAKE HOSE REPLACEMENT

- 1) ✓ Separate the left front brake hose from the brake tube(s) at the frame bracket. Plug tube(s) to prevent brake fluid leakage. Remove retaining clip and separate brake hose from bracket.

**NOTE:** To keep the brake bleeding process to just the front calipers, do not allow the brake fluid to drain completely from the master cylinder reservoir.

- 2) ✓ Remove the brake hose from the caliper. Discard copper washers.
- 3) ✓ Attach left brake hose (hose with the T-shaped fitting and plug) RS170084 to the caliper with NEW copper washers from kit RS860086, and the original bolt. Tighten the bolt to 26 ft.-lbs.

- 4) ✓ If applicable, remove the plug from the new brake hose. Attach the brake hose to the frame bracket and the brake tube(s). Tighten securely.
- 5) ✓ Repeat steps 1 through 4 to install right front brake hose RS170083 (hose with the straight fitting).
- 6) ✓ Refill the master cylinder reservoir with approved brake fluid and bleed the front brakes as follows:
  - Attach a hose to the right front caliper bleeder screw and immerse the other end into a container of clean brake fluid.
  - Have an assistant pump the brake pedal and then hold firm.
  - Loosen the bleeder valve to purge the air from the caliper.
  - Tighten the bleeder valve and slowly release the pedal.
  - Repeat the procedure until all air is purged from the caliper.
  - Attach the hose and container to the left front caliper and repeat the bleeding process. Refill the brake master cylinder reservoir as necessary.

### LEAF SPRING REPLACEMENT

- 1) ✓ Support the front axle with a floor jack.
- 2) ✓ Remove the four U-bolt nuts that secure the left leaf spring to the axle. Remove the U-bolts and the spring plate.
- 3) ✓ Remove the nut and bolt holding the rear of the leaf spring to the spring shackle. See illustration 6. Position the shackle away from the spring.

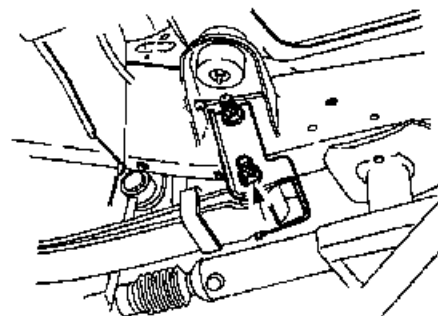

Illustration 6

- 4) ✓ Remove the nut and bolt holding the front of the leaf spring to the hanger bracket. See illustration 7.

**NOTE:** A lower radiator bracket prevents the front mounting bolt (of the leaf spring) from being removed. Remove the radiator bracket first then remove the front bolt.

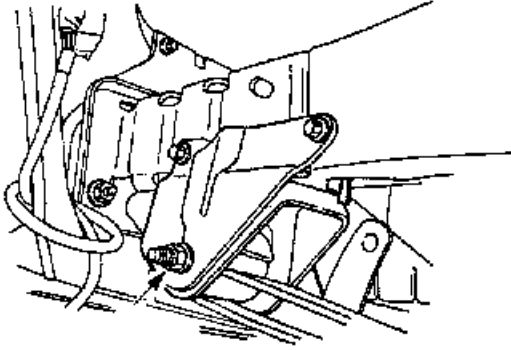

Illustration 7

- 5) ✓ Lower the front axle just enough to remove the leaf spring from the vehicle.
- 6) ✓ Place new leaf spring RS44054 on the axle pad with the large double wrapped eye toward the front
- 7) ✓ Raise the axle and insert the front eye of the spring into the hanger bracket. Install the bolt and nut. Do not tighten at this time.
- 8) ✓ Reinstall the lower radiator bracket.
- 9) ✓ Rotate the shackle over the rear eye of the spring. Loosely install the bolt and nut.
- 10) ✓ Place the spring plate in its original position. Install new U-bolts, washers and nuts (from kit RS8103). Snug down nuts to hold axle and spring together. Do not tighten.
- 11) ✓ Repeat steps 2 through 10 for the passenger side.

**NOTE:** The suspension must be loaded with the weight of the vehicle before the U-bolts and the leaf spring mounting bolts can be tightened.

#### **END LINK RELOCATION & BUMP STOP REPLACEMENT**

- 1) ✓ Remove the bolts attaching the end link bracket to the inside of the frame rail. Refer back to illustration 1.
- 2) ✓ Invert the end link bracket and place it against the bottom of the frame rail over the original mounting holes. Attach the bracket to the frame with the original hardware.

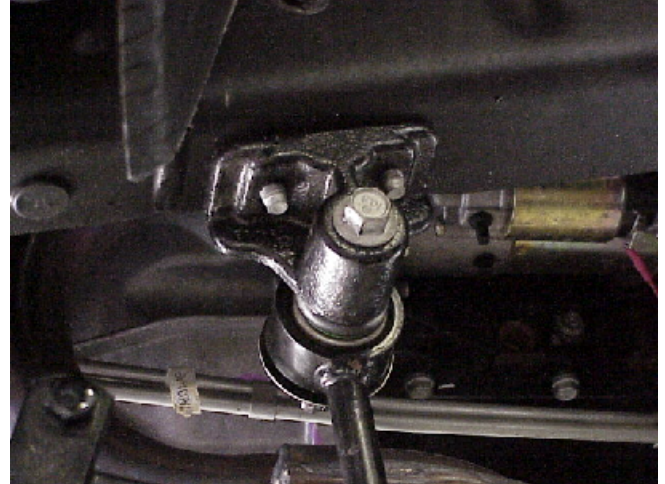

Illustration 8

- 3) ✓ Remove the axle bump stop from the frame rail. See illustration 9.

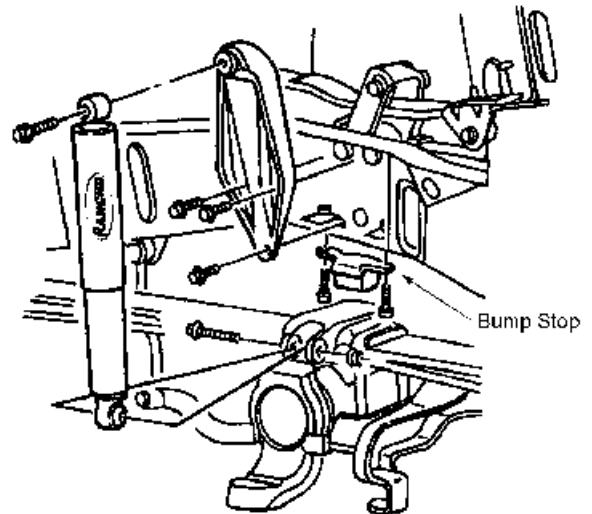

Illustration 9

- 4) ✓ Temporarily attach a new bump stop (RS1403) to the frame rail at the original location. Use the bump stop center stud and a 3/8" nut from kit RS8105.
- 5) ✓ Align bump stop and mark the two additional mounting hole locations on the bottom of the frame rail. Remove bump stop and drill a 3/8" hole at each of the marked locations.

6) ✓ Reattach the new bump stop with the 3/8" bolts, washers, and nuts from kit RS8105. Tighten all nuts and bolts.

7) ✓ Repeat steps 1 through 6 for other side.

### **FINAL ASSEMBLY**

1) ✓ Install new Rancho RS9000 adjustable front shock absorbers.

**NOTE:** Set the adjustable shock to a stiffer setting (3 or 4) for single shock applications. Set the shock to a softer setting (1 or 2) if you are installing dual shock kit RS6742.

2) ✓ If applicable, adjust the ABS wires and attach them to the new brake hoses with the supplied tie wraps. Attach the brake hose assemblies to the front shock absorbers as shown in illustration 10.

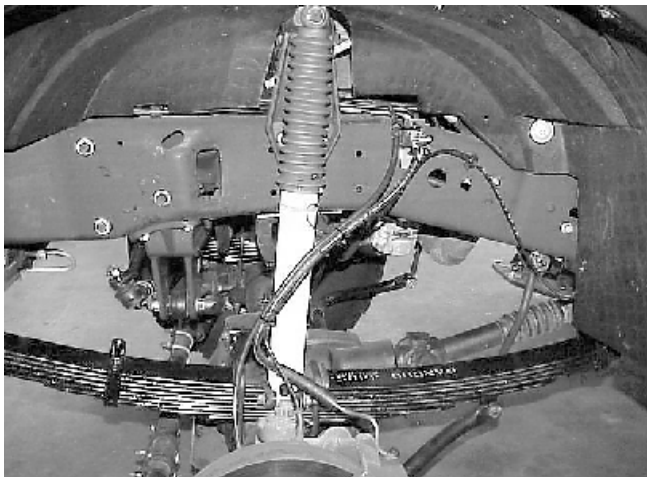

Illustration 10

3) ✓ Re-install front wheels and lower vehicle to ground. Tighten lug nuts to 148 ft.-lbs.

4) ✓ On both sides of the vehicle, tighten the leaf spring rear mounting bolt to 185 ft.-lbs. and the front mounting bolt to 259 ft.-lbs.

5) ✓ Tighten the front U-bolt nuts evenly to 99 ft.-lbs. Use the tightening sequence shown in illustration 11.

6) ✓ Attach the end link assemblies to the frame rail brackets with the original hardware. Refer back to illustration 8.

7) ✓ Tighten the bolts holding the sway bar to the axle bracket.

8) ✓ For vehicles manufactured on or before April 1st 1999: Attach trackbar to drop bracket RS176079 with the original bolt, and a new 14mm nut and washer from kit RS860150. Tighten the nut and bolt to 129 ft.-lbs.

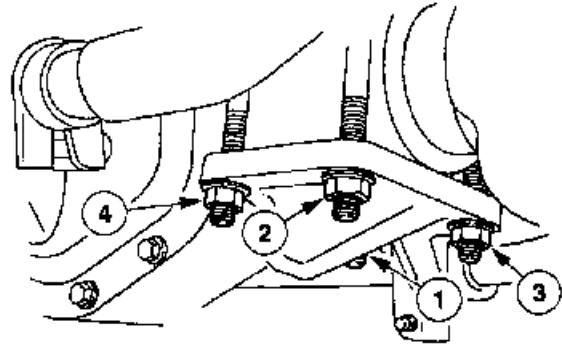

Illustration 11

9) ✓ For vehicles manufactured after April 1st 1999: Attach trackbar to drop bracket RS176093 with the original 19mm hardware. Tighten the nut and bolt to specifications.

## **REAR SUSPENSION**

### **LEAF SPRING REPLACEMENT**

1) ✓ Chock front wheels. Raise the rear of the vehicle and support the frame with jack stands. Remove the rear wheels and set them aside.

2) ✓ Support the rear axle assembly with a floor jack. Remove both rear shock absorbers. Do not reuse the original equipment shock absorbers.

3) ✓ Remove the U-bolt nuts that secure the axle to the right rear spring. See illustration 12. Remove the U-bolts and the upper spring plate.

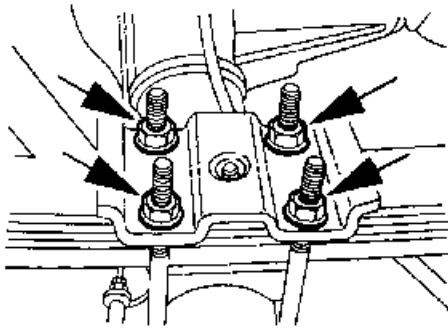

Illustration 12

4) ✓ If equipped, remove the auxiliary spring and auxiliary spring spacer.

5) ✓ Remove the nut and bolt from the rear spring front hanger bracket. See illustration 13.

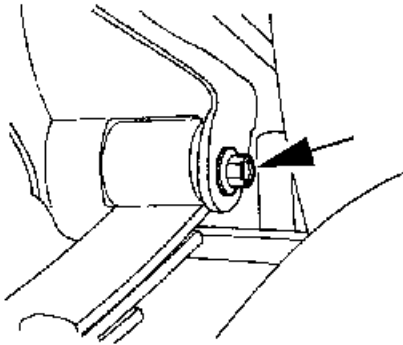

Illustration 13

6) ✓ Remove the lower nut and bolt from the rear spring shackle bracket. See illustration 14. Slightly lower the axle and remove the spring assembly.

7) ✓ Remove the upper nut and bolt from the rear spring shackle assembly and remove the shackle.

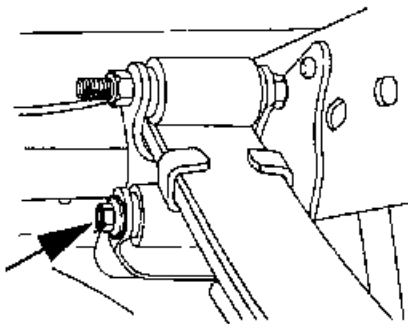

Illustration 14

8) ✓ Attach the shackle to the rear (smaller eye) of new leaf spring RS44154 with the original hardware. Install the upper shackle bolt as shown in illustration 14. Do not tighten.

9) ✓ Place the new leaf spring, with the large double wrapped eye toward the front, on the spring spacer (riser block).

**NOTE:** Ford installs various heights of spring spacers, depending on the options purchased and the vehicle's wheelbase. Rancho spring RS44154 was designed for a 3 3/4" spacer. If your vehicle has smaller spacers, it may sit low in the rear. You can purchase the larger spacers from Ford to correct this situation. The Ford part numbers are: 5598-FA (L/H) & 5598-GA (R/H).

10) ✓ Raise the axle and insert the front eye of the spring into the hanger bracket. Install the original bolt and nut. Do not tighten at this time.

11) ✓ Insert the shackle into the rear hanger and install the original bolt and nut. Do not tighten.

12) ✓ If applicable, install the auxiliary spring and auxiliary spring spacer.

13) ✓ Install the spring upper plate and attach the leaf spring to the axle with the original U-bolts and nuts. Snug down nuts to hold axle and spring together. Do not tighten.

14) ✓ Repeat steps 3 through 13 to replace the rear leaf spring on the left side.

### **FINAL ASSEMBLY**

1) ✓ Replace the lower sleeve in both Rancho shock absorbers (RS9012) with sleeve P01013. Install the new rear shocks.

2) ✓ Re-install rear wheels and lower vehicle to ground. Tighten lug nuts to 148 ft.-lbs.

3) ✓ Using a cross pattern, tighten the rear U-bolt nuts evenly to 185 ft.-lbs.

4) ✓ Tighten all rear leaf spring mounting bolts to 185 ft.-lbs.

### **FINAL CHECKS AND ADJUSTMENTS**

1) ✓ Remove wheel chocks and turn the front wheels completely left then right. Verify adequate tire, wheel, and brake hose clearance. Inspect steering and suspension for tightness and proper operation.

2) ✓ Readjust headlamps. Have vehicle aligned to manufacturer's specifications.

### General Alignment Specifications (4X4)

Castor	$4.0^{\circ} \pm 1^{\circ}$
Camber	$0.25^{\circ} \pm 1^{\circ}$
Toe-In	$0^{\circ} \pm 0.25^{\circ}$

## RANCHO INDUSTRIES USA LIMITED WARRANTY

### ABOUT OUR WARRANTY

Rancho Industries USA, warrants the listed products for the listed time period and/or mileage to the original retail purchaser against defect and wear-out when used on passenger cars and light trucks under normal operating conditions. The warranty does not apply to Rancho products which have been improperly applied or installed. The consumer will be responsible for removing from the vehicle and returning any defective item(s), transportation costs prepaid, to the dealer from which it was purchased or a Rancho Authorized Installer, and for reinstallation of the part upon return. A copy of the sales receipt is required for all warranty adjustments. Rancho Industries will, without charge, repair or replace at its option, defective products or component part(s).

In the case that the customer is unable to return to the original place of purchase or an Authorized Installer, the consumer may contact Rancho Industries at 1-800-574-6257 to obtain a Return Authorization Number prior to shipping. The consumer will be responsible for removing from the vehicle and returning any defective item(s), transportation cost pre-paid, to the following address: 1 International Drive, Monroe MI. 48161. A copy of the sales receipt is required for any warranty adjustments. Rancho Industries will, without charge, repair or replace at its option, defective products or component part(s). Such item(s) will be returned with transportation costs prepaid within the United States from Rancho Industries. The customer will be responsible for reinstallation.

Exclusions from this warranty are sales outside of the United States, the finish, any condition(s) caused by abnormal use or service, and product-specific limitations, if any, listed below.

THE LOSS OF USE OF THE PRODUCT, LOSS OF TIME, INCONVENIENCE, COMMERCIAL LOSS OR CONSEQUENTIAL DAMAGES ARE NOT COVERED. RANCHO INDUSTRIES RESERVES THE RIGHT TO CHANGE THE DESIGN OF ANY PRODUCT WITHOUT ASSUMING ANY OBLIGATION TO MODIFY ANY PRODUCT PREVIOUSLY MANUFACTURED.

THIS WARRANTY GIVES YOU SPECIFIC LEGAL RIGHTS AND YOU MAY ALSO HAVE OTHER RIGHTS WHICH MAY VARY FROM STATE TO STATE. SOME STATES DO NOT ALLOW LIMITATIONS ON HOW LONG AN IMPLIED WARRANTY LASTS OR ALLOW THE EXCLUSION OR LIMITATION OF INCIDENTAL OR CONSEQUENTIAL DAMAGES, THE ABOVE LIMITATION OR EXCLUSION MAY NOT APPLY TO YOU.

THERE ARE NO WARRANTIES, EXPRESSED OR IMPLIED INCLUDING ANY IMPLIED WARRANTIES OF MERCHANTABILITY AND FITNESS, WHICH EXTEND BEYOND THIS WARRANTY PERIOD. THERE ARE NO WARRANTIES THAT EXTEND BEYOND THE FACE HEREOF. SELLER DISCLAIMS IMPLIED WARRANTY OF MERCHANTABILITY.

THIS WARRANTY SHALL NOT APPLY TO ANY RANCHO PRODUCT WHICH HAS BEEN MODIFIED, CUSTOMIZED OR IMPROPERLY INSTALLED. WARRANTY DOES NOT APPLY TO ANY RANCHO

COMPONENTS USED FOR RACING PURPOSED, OR RACE TYPE ACTIVITIES. WARRANTY DOES NOT APPLY TO ANY RANCHO INDUSTRIES RACING PRODUCTS.



The product, time periods and/or mileage under this warranty are as follows:

**RS1000 / RS5000 / RS5600 / RS9000**

**LIMITED LIFETIME WARRANTY**

Limited lifetime warranty on these Rancho shock absorbers. Rancho Industries warrants each new shock against factory defects in material and workmanship (except for finish, including the shock boot) for as long as the original retail purchaser owns the vehicle on which the units were originally installed.

**AIR RANCHO / RC9000 REMOTE CONTROL**

**LIMITED 2 YEAR, 24,000 MILE WARRANTY**

Limited 2 year, 24,000 mile warranty on these Rancho products. Rancho Industries warrants each new RS4000, Air Rancho shock and RC9000 Remote Control System against factory defects in material and workmanship (except for finish, including shock boot) for the first to occur of 2 years or 24,000 miles after the date of purchase.

**SUSPENSION COMPONENTS LIMITED LIFETIME WARRANTY**

Limited lifetime warranty on all of Rancho's suspension products. Rancho Industries warrants each new Suspension Component against factory defects in material and workmanship (except finish) for as long as the original retail purchaser owns the vehicle on which the products were originally installed.

**POWERFLOW EXHAUST LIMITED LIFETIME WARRANTY**

Limited lifetime warranty on all of Rancho's PowerFlow exhaust products. Rancho Industries warrants each of its exhaust products against factory defects in material and workmanship (except finish) for as long as the original retail purchaser owns the vehicle on which the products were originally installed. THIS LIMITED WARRANTY DOES NOT COVER THE FOLLOWING:

- Exhaust system parts that rust or are blown-out by faulty engine conditions
- Any component that has been modified, customized, or improperly installed
- Any part that is obsolete and is no longer available or supplied by Rancho

**RIGHTS RESERVED**

Rancho Industries reserves the right to make changes in design, material and specifications or to make product changes as deemed necessary without prior notice. Obligations or liabilities will not be assumed with respect to similar products previously advertised.

WARRANTY DOES NOT APPLY TO ANY RANCHO COMPONENTS USED FOR RACING PURPOSES, OR RACING TYPE ACTIVITIES. WARRANTY DOES NOT APPLY TO ANY RANCHO INDUSTRIES RACING PRODUCTS.

**PRINTING ERRORS**

Every effort has been made to avoid printing errors in our literature. However, if there are any specification or application errors, we must disclaim responsibility.

This document was created with Win2PDF available at <http://www.daneprairie.com>.  
The unregistered version of Win2PDF is for evaluation or non-commercial use only.