

VARIOUS TOYOTA 4-RUNNER 4WD / TACOMA 4WD

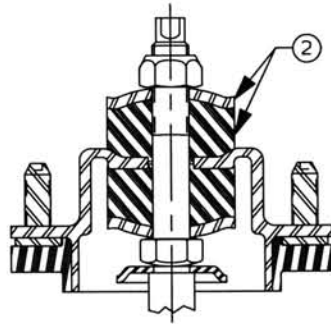

1. REMOVE CUSHION AND DISCARD. MAY REQUIRE FORCE.
 2. ASSEMBLE NEW COMPONENTS AS SHOWN. TIGHTEN NUT UNTIL OUTER DIAMETER OF CUSHION AND RETAINER ARE APPROXIMATELY THE SAME. CUSHION WILL COMPRESS WITH SPRING LOAD PRIOR TO RE-INSTALLATION ON VEHICLE.
1. QUITTE EL AMORTIGUADOR Y DISCARD. PUEDE REQUERIR LA FUERZA.
2. MONTE LOS NUEVOS COMPONENTES SEGUN LO DEMOSTRADO. APRIETE LA TUERCA HASTA QUE EL DIAMETRO EXTERNO DEL AMORTIGUADOR Y EL DETENEDOR SON APPROXIMATELY IGUALES. EL AMORTIGUADOR COMPRIMIRA CON LA CARGA DEL RESORTE ANTES DE LA RE-INSTALACION EN LE VEHICULO.
1. ENLEVEZ LE COUSSIN ET EL DISCARD. PEUT EXIGER LA FORCE.
2. ASSEMBLEZ LES NOUVEAUX COMPOSANTS COMME MONTRES. SERREZ L'ECROU JUSQU'A CE QUE LE DIAMETRE EXTERIEUR DU COUSSIN ET L'ARRETOIR SOIENT APPROXIMATELY LES MEMES. LE COUSSIN SE COMPRIMERA AVEC LA CHARGE DE RESSORT AVANT LA RE-INSTALLATION SUR LE VEHICULE.

FORD EXPLORER

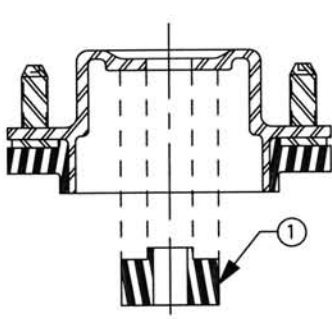
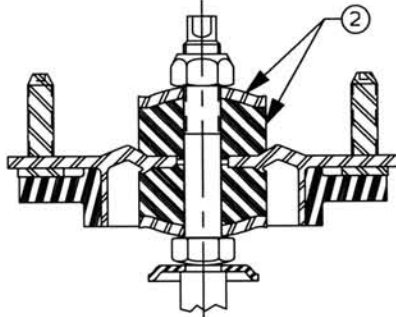
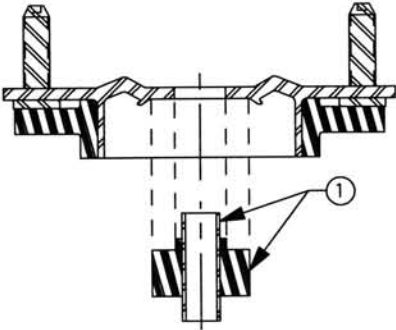

1. REMOVE CUSHION AND SLEEVE (IF APPLICABLE) AND DISCARD. MAY REQUIRE FORCE.
 2. ASSEMBLE NEW COMPONENTS AS SHOWN. TIGHTEN NUT UNTIL OUTER DIAMETER OF CUSHION AND RETAINER ARE APPROXIMATELY THE SAME. CUSHION WILL COMPRESS WITH SPRING LOAD PRIOR TO RE-INSTALLATION ON VEHICLE.
1. QUITTE EL AMORTIGUADOR Y MANGA (SI ES APLICABLE) Y DISCARD. PUEDE REQUERIR LA FUERZA.
2. MONTE LOS NUEVOS COMPONENTES SEGUN LO DEMOSTRADO. APRIETE LA TUERCA HASTA QUE EL DIAMETRO EXTERNO DEL AMORTIGUADOR Y EL DETENEDOR SON APPROXIMATELY IGUALES. EL AMORTIGUADOR COMPRIMIRA CON LA CARGA DEL RESORTE ANTES DE LA RE-INSTALACION EN EL VEHICULO.

NEWER TOYOTA TUNDRA

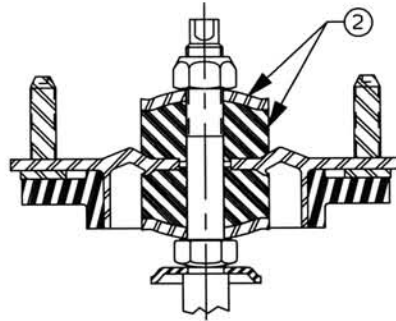
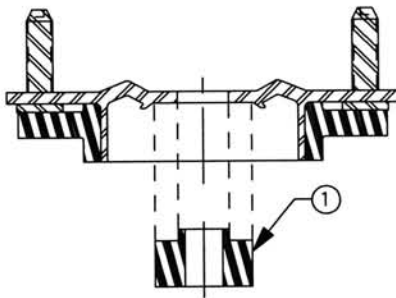

1. ENLEVEZ LE COUSSIN ET LA DOUILLE (SI C'EST APPROPRIE) ET EL DISCARD. PEUT EXIGER LA FORCE.
2. ASSEMBLEZ LES NOUVEAUX COMPOSANTS COMME MONTRES. SERREZ L'ECROU JUSQU'A CE QUE LE DIAMETRE EXTERIEUR DU COUSSIN ET L'ARRETOIR SOIENT APPROXIMATELY LES MEMES. LE COUSSIN SE COMPRIMERA AVEC LA CHARGE DE RESSORT AVANT LA RE-INSTALLATION SUR LE VEHICULE.

VARIOUS TOYOTA 4-RUNNER / TACOMA / TUNDRA / SEQUOIA

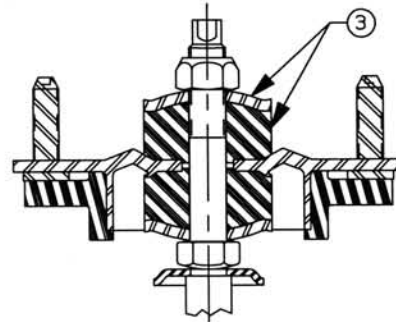
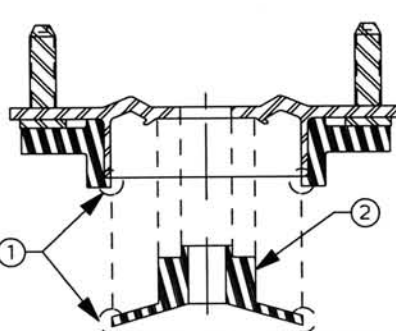

1. CUT WEBBING ALL AROUND.
2. REMOVE CUSHION AND SLEEVE (IF APPLICABLE) AND DISCARD. MAY REQUIRE FORCE.
3. ASSEMBLE NEW COMPONENTS AS SHOWN. TIGHTEN NUT UNTIL OUTER DIAMETER OF CUSHION AND RETAINER ARE APPROXIMATELY THE SAME. CUSHION WILL COMPRESS WITH SPRING LOAD PRIOR TO RE-INSTALLATION ON VEHICLE.

NISSAN FRONTIER / XTERRA / PATHFINDER

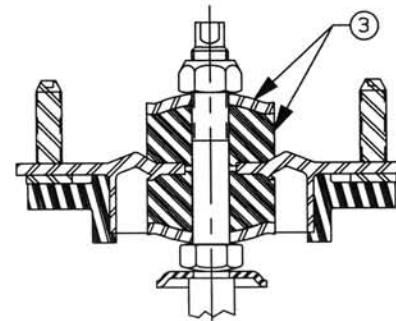
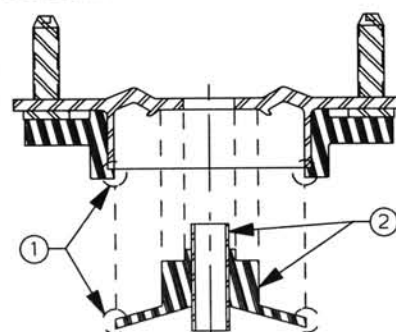

1. CORTE LAS CORREAS TODO ALREDEDOR.
 2. QUITTE EL AMORTIGUADOR Y MANGA (SI ES APLICABLE) Y DISCARD. PUEDE REQUERIR LA FUERZA.
 3. MONTE LOS NUEVOS COMPONENTES SEGUN LO DEMOSTRADO. APRIETE LA TUERCA HASTA QUE EL DIAMETRO EXTERNO DEL AMORTIGUADOR Y EL DETENEDOR SON APPROXIMATELY IGUALES. EL AMORTIGUADOR COMPRIMIRA CON LA CARGA DEL RESORTE ANTES DE LA RE-INSTALACION EN EL VEHICULO.
1. COUPEZ LA SANGLE TOUT AROUND.
2. ENLEVEZ LE COUSSIN ET LA DOUILLE (SI C'EST APPROPRIE) ET EL DISCARD. PEUT EXIGER LA FORCE.
3. ASSEMBLEZ LES NOUVEAUX COMPOSANTS COMME MONTRES. SERREZ L'ECROU JUSQU'A CE QUE LE DIAMETRE EXTERIEUR DU COUSSIN ET L'ARRETOIR SOIENT APPROXIMATELY LES MEMES. LE COUSSIN SE COMPRIMERA AVEC LA CHARGE DE RESSORT AVANT LA RE-INSTALLATION SUR LE VEHICULE.