



www.skyjacker.com

REQUIRED TOOL LIST:

- Safety Glasses
- Metric / Standard Wrenches & Sockets
- Floor Jack
- Jack Stands
- Measuring Tape
- Torque Wrench

1994 - 2001 Dodge 1500 4WD
1994 - 2013 Dodge / Ram 2500 4WD
1994 - 2012 Dodge / Ram 3500 4WD
2.5" Front Metal Spacer Kit
Installation Instructions

Before beginning the installation, thoroughly & completely read these instructions & the enclosed driver's WARNING NOTICE. Affix the WARNING decal in the passenger compartment in clear view of all occupants. Please refer to the Parts List to insure that all parts & hardware are received prior to the disassembly of the vehicle. If any parts are found to be missing, contact SKYJACKER® Customer Service at 318-388-0816 to obtain the needed items. If you have any questions or reservations about installing this product, contact SKYJACKER® Technical Assistance at 318-388-0816.

Make sure you park the vehicle on a level concrete or asphalt surface. Many times a vehicle is not level (side-to-side) from the factory & is usually not noticed until a lift kit has been installed, which makes the difference more visible. Using a measuring tape, measure the front (both sides) from the ground up to the center of the fender opening above the axle. Record this information below for future reference.

Driver Side Front: _____ Passenger Side Front: _____

IMPORTANT NOTES:

- Skyjacker highly recommends this product be installed with new Skyjacker extended length front shocks in order to maintain ride quality & handling.
- If larger tires (10% more than the OEM diameter) are installed, speedometer recalibration will be necessary. Contact your local Dodge / Ram dealer or an authorized dealer for details.
- After installation, a qualified alignment facility is required to align the vehicle to the OEM specifications.

Component Box Breakdown:

Part #: D25MS

Item #	Description	Qty
D25MS-S	2.5" METAL COIL SPRING SPCR	2
HB-D25MS	HDW BAG: D25MS SPACERS	1

Item #	Description	Qty
I-D25MS	INST SHEET: R25MS	1

Hardware Bag Breakdown:

Part # HB-D25MS

Item #	Description	Qty
10MMX30MMB	10MM X 30MM METRIC BOLT	6
10MMPN	10MM METRIC PUSH NUT	6

Item #	Description	Qty
38SAEW	3/8 SAE WASHER	6
10MMN	10MM METRIC LOCK NUT	6

Installation:

1. With the vehicle on a level concrete or asphalt surface, set the emergency brake & block the rear tires / wheels.
2. Lift the front of the vehicle & support the vehicle using jack stands.
3. Remove the front tires / wheels.
4. Support the front axle & remove the OEM upper shock tower brackets. (See Photo # 1)
5. Disconnect the OEM front shocks at each lower mount & remove the OEM front shocks. **Note:** The OEM front shocks will need to be pulled up through the OEM coil springs under the hood of the vehicle in order to be removed.
6. Disconnect the OEM sway bar end links from the OEM sway bar. (See Photo # 2)
7. Disconnect the OEM drag link from the OEM pitman arm.
8. Disconnect the OEM brake line brackets from each control arm bracket. (See Photo # 3)
9. Disconnect the OEM track bar from the upper frame mount.
10. While checking for appropriate slack in ABS lines, brake lines, differential breather hose, & etc. Lower the front axle & remove the OEM coil springs, rubber isolators, & three-bolt tower rings. **Note:** The OEM three-bolt tower rings will not be used for reassembly.

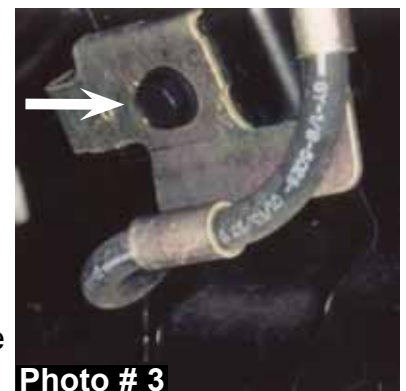
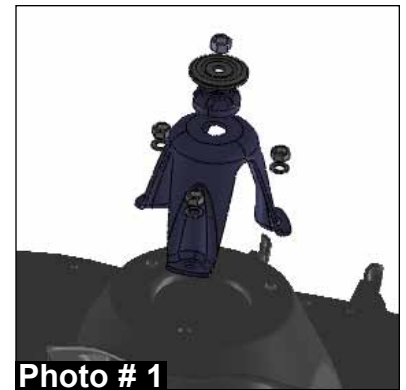

11. Assemble the new Skyjacker metal coil spring spacers using the supplied 10mm x 30mm bolts & 10mm push nuts. (See Photo # 4)
12. Install the new Skyjacker metal coil spring spacers to the OEM coil spring towers using the supplied 10mm nuts & washers. (See Photo # 5) **Do not tighten at this time.**
13. Place the OEM rubber isolators on top of the OEM coil springs & install the OEM coil springs.

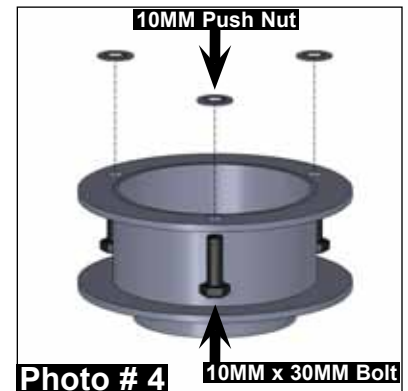

14. Raise the front axle in order to load the OEM coil springs & connect the OEM track bar to the upper frame mount using the OEM hardware.
15. Connect the OEM brake line brackets to each control arm bracket using the OEM hardware. (See Photo # 3)
16. Connect the OEM drag link to the OEM pitman arm using the OEM hardware.



17. Connect the OEM sway bar end links to the OEM sway bar using the OEM hardware. (See Photo # 2)
18. Install the new Skyjacker front shocks & connect the new front shocks at each lower mount using the supplied shock hardware & OEM hardware. **Note:** The new Skyjacker front shocks will need to be placed down through the OEM coil springs under the hood of the vehicle in order to be installed.

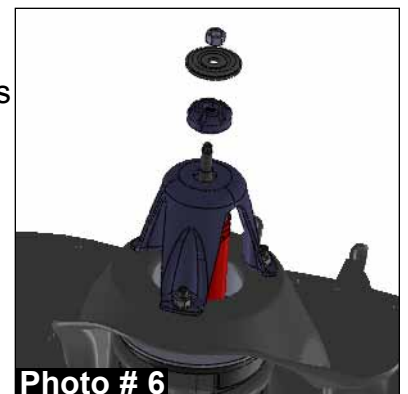

19. Remove the previously installed 10mm nuts & washers from the new Skyjacker metal coil spring spacers & install the OEM upper shock tower brackets using the supplied shock hardware, 10mm nuts, & washers. (See Photo # 6)

20. Install the front tires / wheels & lower the front of the vehicle to the ground.

Final Notes:

- After the installation is complete, double check that all nuts & bolts are tight. Refer to the following chart for the proper torque specifications. (Do not retighten the nuts & bolts where thread lock compound was used.)
- With the vehicle placed on the ground, cycle the steering lock to lock & inspect the steering, suspension, brake lines, front & rear drivelines, fuel lines, & wiring harnesses for proper operation, tightness, & adequate clearance.
- Have the headlights readjusted to the proper settings.

- Have a qualified alignment center align the vehicle to the OEM specifications.
- After the first 100 miles, check all of the hardware for the proper torque & periodically thereafter.

TORQUE SPECIFICATIONS					
<u>INCH SYSTEM</u>			<u>METRIC SYSTEM</u>		
Bolt Size	Grade 5	Grade 8	Bolt Size	Class 8.8	Class 10.9
5/16	15 FT LB	20 FT LB	6MM	5 FT LB	9 FT LB
3/8	30 FT LB	35 FT LB	8MM	18 FT LB	23 FT LB
7/16	45 FT LB	60 FT LB	10MM	32 FT LB	45 FT LB
1/2	65 FT LB	90 FT LB	12MM	55 FT LB	75 FT LB
9/16	95 FT LB	130 FT LB	14MM	85 FT LB	120 FT LB
5/8	135 FT LB	175 FT LB	16MM	130 FT LB	165 FT LB
3/4	185 FT LB	280 FT LB	18MM	170 FT LB	240 FT LB

- The above specifications are not to be used when the bolt is being installed with a bushing.

Seat Belts Save Lives, Please Wear Your Seat Belt.