

SUPERWINCH®



OWNER'S MANUAL

INSTALLATION • OPERATION • MAINTENANCE
SAFETY PRECAUTIONS • REPAIR PARTS

EP/EPi6.0 and EP/EPi9.0
12 & 24 Volt DC Electric Winch

▲ CAUTION

**READ AND UNDERSTAND THIS MANUAL BEFORE INSTALLATION
AND OPERATION OF YOUR SUPERWINCH PRODUCT.**

Superwinch, Inc.
Winch Drive
Putnam, CT 06260
U.S.A.
Tel. (860) 928-7787
Fax (860) 963-0811

Superwinch, Ltd.
Abbey Rise, Whitchurch Road
Tavistock, Devon PL 19 9DR
England
Tel. +44 (0) 1822 614101
Fax +44 (0) 1822 615204

INTRODUCTION

Thank you for purchasing an EP series winch from Superwinch. It has been designed and manufactured to provide years of trouble-free operation. We hope you will be pleased with its performance. If you are not, for any reason, please contact our Customer Service Department: (860) 928-7787 USA; +44 (0) 1822 614101 England.

When requesting information or ordering replacement parts; always give the following information:

1. Winch Part Number
2. Serial Number
3. Part Number
4. Part Description

Note: Winch specifications and equipment may vary from country to country.

The responsibility for safe installation and operation of this winch ultimately rests with you, the operator. Read and understand all safety precautions and operating instructions before installing and operating the winch. Careless winch operation can result in serious injury and/or property damage.

Throughout this manual, you will find notations with the following headings:

- ⚠ DANGER** Indicates an imminently hazardous situation which, if not avoided, will result in death or serious injury.
- ⚠ WARNING** Indicates a potentially hazardous situation which, if not avoided, could result in death or serious injury.
- ⚠ CAUTION** Indicates a potentially hazardous situation which, if not avoided, may result in minor or moderate injury. This notation is also used to alert against unsafe practices.

The following symbols on the product and in the Owner's manual are used:



Read Owner's Manual



Always Use Handsaver



Keep clear of winch, wire rope and hook while operating



Never use winch to lift or move people



Never use winch to hold loads in place

Note: Indicates additional information in the installation and operation procedures of your winch.

Correct installation of your winch is a requirement for proper operation.

Please Note: Winch is designed primarily for intermittent applications. This winch is not designed to be used in hoisting applications and Superwinch does not warrant it to be suitable for such use. Please contact our Customer Service Department for further information.

Congratulations on your choice!

Superwinch is not responsible for printing errors inadvertently made in the production of this manual.

ROLLING LOAD CAPACITIES

Model		Slope			
		10% (6°)	20% (11°)	30% (17°)	100% (45°)
EP/EPi 6.0	Lbs.**	29,410	20,760	15,460	7,710
	kg**	13,340	9,140	7,010	3,500
EP/EPi 9.0	Lbs.**	45,225	30,600	23,500	11,573
	kg**	20,514	13,880	10,659	5,250

Ratings assume a 10% coefficient of friction.

* A 10% slope is a rise of one foot in ten feet. Slope in approximate degrees is also shown above

** All loads shown are for single-line operation. Double-line operation with optional pulley block (p/n 7750A) approximately doubles capacity of winch.

UNPACKING

This carton contains the following items. Please unpack carefully.

Read instructions before beginning.

Description	Quantity
Winch assembly with wire rope	1
Handsaver	1
Remote switch	1
Clevis hook, roller fairlead, pulley block	1
Owner's manual	1

FEATURES

1. Electric Motor – 12V series wound and 24V series wound.

2. Braking – Automatic load-holding brake.

Drum – Fabricated steel

Freespool Clutch – Operated by an easy action lever which

disengages the ring gear to allow the wire rope to be pulled out without using electric power.

Remote Switch – 15' handheld pendant switch assembly.

DIMENSIONS

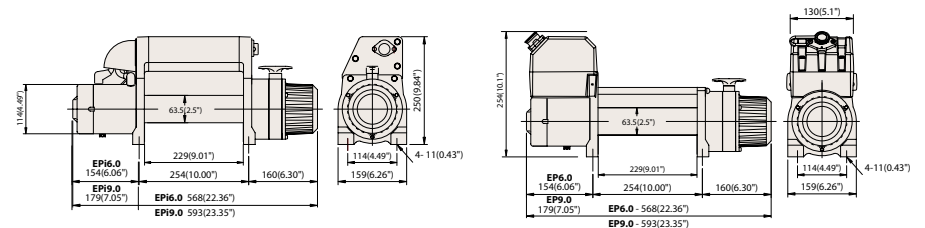

INTERMITTENT DUTY

An electric winch is like any other motor driven power tool such as an electric drill or saw. The electric motor should not be allowed to become excessively hot. Normal precautions will extend the life of your motor. Keep the duration of pulls as short as possible. **If the end of the motor becomes uncomfortably hot to touch**, stop winching and allow the motor to cool down.

PERFORMANCE

EP/EPI 6.0			EP/EPI 9.0		
Wire Rope Layer	Max. Pulling Capacity		Wire Rope Layer	Max. Pulling Capacity	
	lbs.	kg		lbs.	kg
1	6,000	2722	1	9,000	4082
2	5,465	2477	2	8,190	3715
3	5,000	2268	3	7,500	3402
4	4,670	2118	4	7,010	3180
5			5	6,570	2980

Line Speed and Amp Draw									
		EP/EPI 6.0		EP/EPI 9.0					
Load Lbs.	kg	Line Speed*		AMP Draw		Line Speed*		AMP Draw	
		FPM	MPM	12V	24V	FPM	MPM	12V	24V
0	0	48	14.6	40	24	44	13.4	33	15
2,000	907	23	7	170	102	15	4.6	110	55
4,000	1814	13	4	350	210	11	3.4	200	100
6,000	2722	10	3.1	440	264	9	2.7	230	115
8,000	3629	NA	NA	NA	NA	7.5	2.3	260	130
9,000	4082	NA	NA	NA	NA	6.4	2	350	210

SPECIFICATIONS

	EP/EPI 6.0	EP/EPI 9.0
Working Load*	6000 lbs. (2722 kg)	9000 lbs. (4082 kg)
Wire Rope	100' x 21/64"	125' x 21/64"
EP 6.0/9.0		
EPI 6.0/9.0		
Motor Type	Series Wound	Series Wound
Motor Output 12V	3.6 HP	4.6 HP
Motor Output 24V	2.0 HP	2.6 HP
Clutch	Sliding Ring Gear	Sliding Ring Gear
Brake	Auto. Load-holding	Auto. Load-holding
Gear Ratio	156:1	156:1

* Based on first layer performance

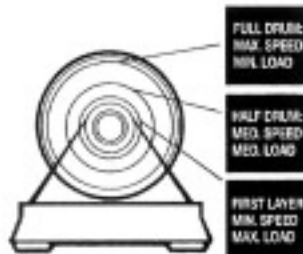

CAUTION If the winch motor stalls, do not continue to apply power to the winch.

CAUTION Brake housing will get hot during extended power out operation.

GENERAL SAFETY INFORMATION

Your winch is a very powerful machine. Treat it with respect, use it with caution and always follow these safety guidelines.

WARNING The responsibility for safe installation and operation of the winch and prevention of personal injury and property damage ultimately rests with you, the operator. There is no substitute for the use of good judgement and caution in operating a winch.

WARNING The wire rope may break before the winch stalls. For heavy loads, use a pulley block to reduce the load on the wire rope.

1. Do not maintain power to the winch if the motor stalls. Overloads can damage the winch and/or the wire rope and create unsafe operating conditions. FOR LOADS OVER 2/3 RATED CAPACITY, WE RECOMMEND THE USE OF THE OPTIONAL PULLEY BLOCK TO DOUBLE LINE THE WIRE ROPE (Figures 1). This reduces the load on the winch and the strain on the wire rope by approximately 50%. If attaching back to vehicle, attach to the frame or other load bearing part. **The vehicle engine should be running during winch operation to minimize battery drain and maximize winch power and speed.** If considerable winching is performed with the engine off, the battery may be too weak to restart the engine.

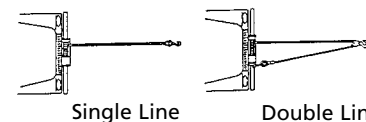

Figure 1

2. AFTER READING AND UNDERSTANDING THIS MANUAL, LEARN TO USE YOUR WINCH. After installing the winch, practice using it so you will be familiar with it when the need arises.
3. DO NOT "move" your vehicle to assist the winch in pulling a load. The combination of the winch and vehicle pulling together could overload the wire rope and the winch itself.
4. KEEP WINCHING AREA CLEAR. Do not allow people to remain in the area during winching operations. ALWAYS STAND CLEAR OF WIRE ROPE/HOOK AND WINCH. IN THE UNLIKELY EVENT OF ANY COMPONENT FAILURE IT'S BEST TO BE OUT OF HARM'S WAY.
5. INSPECT WIRE ROPE AND EQUIPMENT FREQUENTLY. **A FRAYED WIRE ROPE WITH BROKEN STRANDS SHOULD BE REPLACED IMMEDIATELY.** Always replace wire rope with the manufacturer's identical replacement part (see Replacement Parts List). Periodically check the winch installation to ensure that all bolts are tight.
6. USE HEAVY LEATHER GLOVES when handling wire rope. DO NOT LET WIRE ROPE SLIDE THROUGH YOUR HANDS EVEN WHEN WEARING GLOVES.



GENERAL SAFETY INFORMATION (CONT.)

7. NEVER WINCH WITH LESS THAN 5 TURNS of wire rope AROUND THE WINCH DRUM since the wire rope end fastener will NOT withstand a load. Your winch wire rope has a ten-foot red "warning indicator" on each end. The "warning indicator" at the winch end warns you that the wire rope is near or less than 5 turns. The "warning indicator" at the hook end of the wire rope warns you that the hook is approaching the winch. ALWAYS USE THE HANDSAVER when guiding the wire rope in or out (see Figure 2). As you use your winch, the red paint will wear off due to normal use. When this happens, renew the red paint as it is a **safety feature of the winch.**



Figure 2

8. KEEP CLEAR OF WINCH, TAUT WIRE ROPE AND HOOK WHEN OPERATING WINCH. Never put your finger through the hook. If your finger should become trapped in the hook, you could be injured. **Never guide a wire rope onto the drum with your hand.**
9. NEVER HOOK THE WIRE ROPE BACK ONTO ITSELF. You could damage the wire rope. Use a nylon sling (Figure 3).



Figure 3

10. Lay a heavy blanket or jacket over the wire rope near the hook end when pulling heavy loads (Figure 4). Should a wire rope failure occur, the cloth will act as a damper and help prevent the rope from whipping. Raise the hood of the vehicle for added protection.

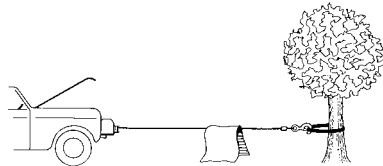

Figure 4

11. NEVER USE YOUR WINCH FOR LIFTING PEOPLE OR MOVING PEOPLE.
12. Your winch is not intended for overhead hoisting operations.
13. AVOID CONTINUOUS PULLS FROM EXTREME ANGLES as this will cause the wire rope to pile up at one end of the drum (Figure 5). This can jam the wire rope in the winch, causing damage to the wire rope or winch itself.

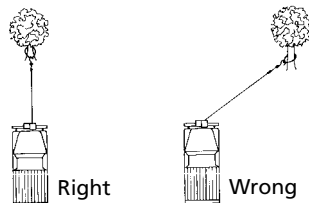
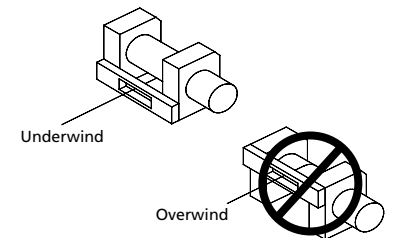

Figure 5

GENERAL SAFETY INFORMATION (CONT.)

14. NEVER OBSCURE THE WARNING INSTRUCTION LABELS.
15. Always operate winch with an unobstructed view of the winching operation.
16. Equipment such as tackle, hooks, pulley blocks, straps, etc. should be sized to the winching task and should be periodically inspected for damage that could reduce their strength.
17. NEVER RELEASE FREESPOOL CLUTCH WHEN THERE IS A LOAD ON THE WINCH.
18. STORE THE REMOTE PENDANT ASSEMBLY IN A SAFE PLACE when not in use to prevent use by children or other unauthorized persons who could injure themselves or others.
19. DO NOT OPERATE WINCH WHEN UNDER THE INFLUENCE OF DRUGS, ALCOHOL OR MEDICATION.
20. ALWAYS UNPLUG THE REMOTE PENDANT BEFORE WORKING IN OR AROUND THE FAIRLEAD OR WINCH DRUM (THE DANGER ZONE) so that the winch cannot be turned on accidentally.
21. When moving a load, slowly take up the wire rope slack until it becomes taut. Stop, recheck all winching connections. Be sure the hook is properly seated. If a nylon sling is used, check the attachment to the load.
22. When using your winch to move a load, place the vehicle transmission in neutral, set vehicle parking brake, and chock all wheels.

23. DO NOT USE THE WINCH TO HOLD LOADS IN PLACE. Use other means of securing loads such as tie down straps. Superwinch offers a wide variety of tie downs. Contact your local Superwinch dealer.
24. USE ONLY FACTORY APPROVED SWITCHES, REMOTE CONTROLS AND ACCESSORIES. Use of non-factory approved components may cause injury or property damage and could void your warranty.
25. DO NOT MACHINE OR WELD ANY PART OF THE WINCH. Such alterations may weaken the structural integrity of the winch and will void your warranty.
26. DO NOT CONNECT WINCH TO EITHER 110 VOLT AC HOUSE CURRENT OR 220V MAINS AS WINCH BURNOUT OR FATAL SHOCK MAY OCCUR.
27. Never allow shock loads to be applied to winch or wire rope.
28. Always operate your winch in an underground orientation only.



INSTALLATION

MOUNTING YOUR WINCH

⚠ WARNING *Improper mounting can cause personal injury.*

Improper mounting could damage your winch and void warranty.

MINIMUM ELECTRICAL REQUIREMENTS

For 12 Volt winches, a 60 amp alternator and battery with 440 cold-cranking amperes capacity are the minimum recommended power sources. If the winch is in heavy use, an auxiliary battery is recommended.

Under some circumstances, it may be appropriate to install additional circuit protection devices (circuit breakers). If in doubt, seek appropriate advice.

Superwinch recommends that all inch electrical systems can be readily and quickly isolated from their electrical supply in the event of an emergency. The winch electrical system should always be isolated when the winch is not in use.

1. Install mounting kit or structural support for winch.
2. Mount the winch to a mounting kit base plate or to the mount that you designed.

⚠ WARNING *Do not substitute any strength grade weaker than SAE Grade 8 (ISO 10.9).*

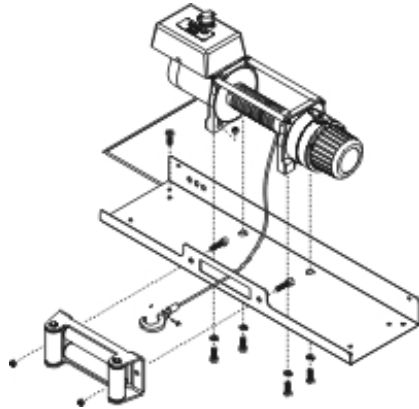

EP 6.0/9.0

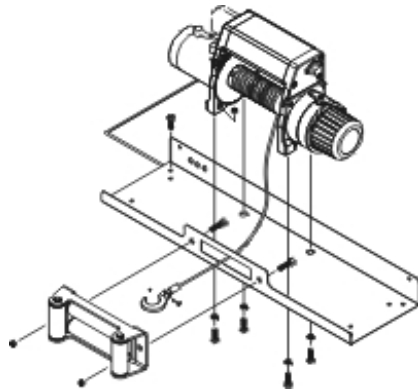

EPi 6.0/9.0

⚠ WARNING *Automobile batteries contain gasses which are flammable and explosive. Wear eye protection during installation and remove all metal jewelry. Do not lean over battery while making connections.*

3. Route the long red and black color coded wires to the battery. To ensure against insulation abrasion and/or cutting, apply several layers of electrical tape where wiring may come in contact with sharp parts on the vehicle. Attach the red color coded wire to the battery positive terminal, and reattach the terminal to the battery.

If your vehicle is equipped with side pole terminals, it may be necessary to obtain auxiliary side terminal bolts from your local auto parts dealer to make these connections.

Connect the black color coded wire to the battery negative terminal, then connect the terminal to the battery.

4. Turn the freespool clutch lever to the "free" position. Pull several feet of wire rope off the drum. Return the clutch lever back to the "Engage" position. Plug in remote pendant control. Push button momentarily to check wire rope drum rotation direction. If drum rotates in the wrong direction, recheck your wiring.

⚠ CAUTION *To prevent unauthorized use of the winch, remove pendant control and store in a clean dry area such as the glove box.*

PENDANT OPERATION

Cable Out



Figure 6

Cable In



Figure 7

The handheld pendant switch activates a solenoid that activates power to the winch motor.

To connect the pendant control, remove the cover on the plug receptacle and insert the plug end of remote switch. The plug on the pendant control cord is keyed and will fit into the socket only one way.

The switch trigger returns to the "Off" position when released.

To change direction, move the toggle in the other direction.

⚠ CAUTION *The switch assembly must be kept free of dirt and moisture to ensure safe operation.*

PULLING OUT THE WIRE ROPE

The wire rope has been installed on your winch under minimal load at the factory. The wire rope must be respoiled onto the drum under load so that the outer layers will not draw down into the inner ones thereby damaging the wire rope.

Rotate the clutch lever to the "Free" position as shown in Figure 8. If there is a load on the wire rope, the clutch lever may not turn easily. **DO NOT FORCE THE CLUTCH LEVER.** Release tension on the wire rope by jogging out some of the wire rope, then try releasing the clutch. Pull out the wire rope and secure to anchor or load. Check that there are at least five (5) turns of wire rope left on the drum. Re-engage the drum by rotating the clutch lever to the "Engaged" position (see Figure 8).

CAUTION *Lever must be in the engaged position and locked before winching.*

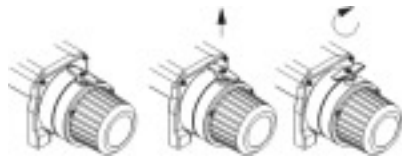

Figure 8

TIPS FOR EXTENDING THE LIFE OF THE WINCH

1. **KEEP A TIGHTLY WOUND WIRE ROPE DRUM.** Do not allow the wire rope to become loosely wound. A loosely-wound drum allows a wire rope under load to work its way down into the layers of wire rope on the drum. When this happens, the wire rope may become wedged within the body of the windings damaging the wire rope. To prevent this problem, keep the wire rope tightly and evenly wound on the drum

at all times. A good practice is to rewind the wire rope under tension after each use. One way to do this is to attach the hook to a stationary object at the top of a gradual incline and winch your vehicle up the incline.

2. **DO NOT ALLOW WINCH MOTOR TO OVERHEAT.** Remember, the winch is for intermittent use only. During long or heavy pulls the motor will get hot. The internal parts will be hotter than the case. To check the motor temperature, stop winching and carefully touch the motor case, if the motor is uncomfortable to touch, allow the motor to cool before continuing. **KEEP THE ENGINE RUNNING TO RECHARGE THE BATTERY** during this break.
3. To maximize winch and wire rope life, use a pulley block to double line heavier loads (Figure 9).



Figure 9

4. The pull required to start a load moving is often much greater than the pull required to keep it moving. **AVOID FREQUENT STOPPING AND STARTING** during pull.
5. **PREVENT KINKS BEFORE THEY OCCUR.**

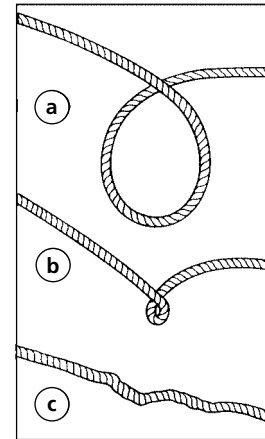

Figure 10

a. This is the start of a kink. Wire rope should be straightened.
b. Wire rope was pulled and loop has tightened into a kink. Wire rope is now permanently damaged and must be replaced.
c. Result of kinking is that each strand pulls a different amount causing strands under greatest tension to break and reduce load capacity of wire rope. The wire rope must be replaced.

6. **EQUIPPING THE WINCH WITH A ROLLER FAIRLEAD** will substantially reduce wear on the wire rope during angle pulls (Figure 11). The rollers eliminate heavy rubbing and abrasion to the wire rope.



Figure 11

MAINTENANCE

Periodically check tightness of mounting bolts and electrical connections. Remove any dirt or corrosion that may have accumulated on the electrical connections.

Repairs should be done by Authorized Superwinch Repair Centers ONLY. Do not attempt to disassemble the gearbox. Disassembly will void warranty.

LUBRICATION

The gearbox and drum bearing are permanently lubricated with a high performance gear lube.

REPLACING THE WIRE ROPE

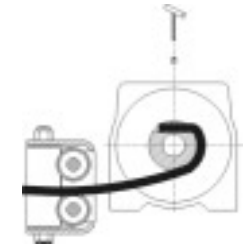

Figure 12

Never substitute a heavier or lighter wire rope. Never use rope made of any other material other than wire.

Always replace damaged wire rope with manufacturer's identical replacement part (see Replacement Parts list). Pass attaching end of wire rope through the fairlead (if equipped) and attach it to the drum. When inserting the wire rope into the drum, insert it into the correct end of the hole provided (Figure 12). Tighten the set screw securely.

It is important that the wire rope be wound tightly onto the drum. A good way to do this is to attach the wire rope hook to a fixed object at the top of a slight incline, then winch the vehicle up the incline.

When wire rope is removed from the drum, as in bringing the hook to the load, the freewheel feature of the winch should be used.

BRAKE ADJUSTMENT

Over time, the load-holding brake in your winch will wear. Should you find the load beginning to slip, adjustments can be made to the brake mechanism as follows:

- 1) Loosen the 3 retaining bolts and remove the brake cover. (Ref.#25 Figs. 13, 14)
- 2) Remove the two retaining C-rings. (Ref.#35 Figs. 13, 14)
- 3) Insert washers to maintain a spacing of .090" +/- .010" between the C-ring grooves and the brake actuating cam. (Ref.#21 Figs. 13, 14)
- 4) Re-install the two C-rings and brake cover.

EP SERIES WINCH ASSEMBLY

REPLACEMENT PARTS LIST

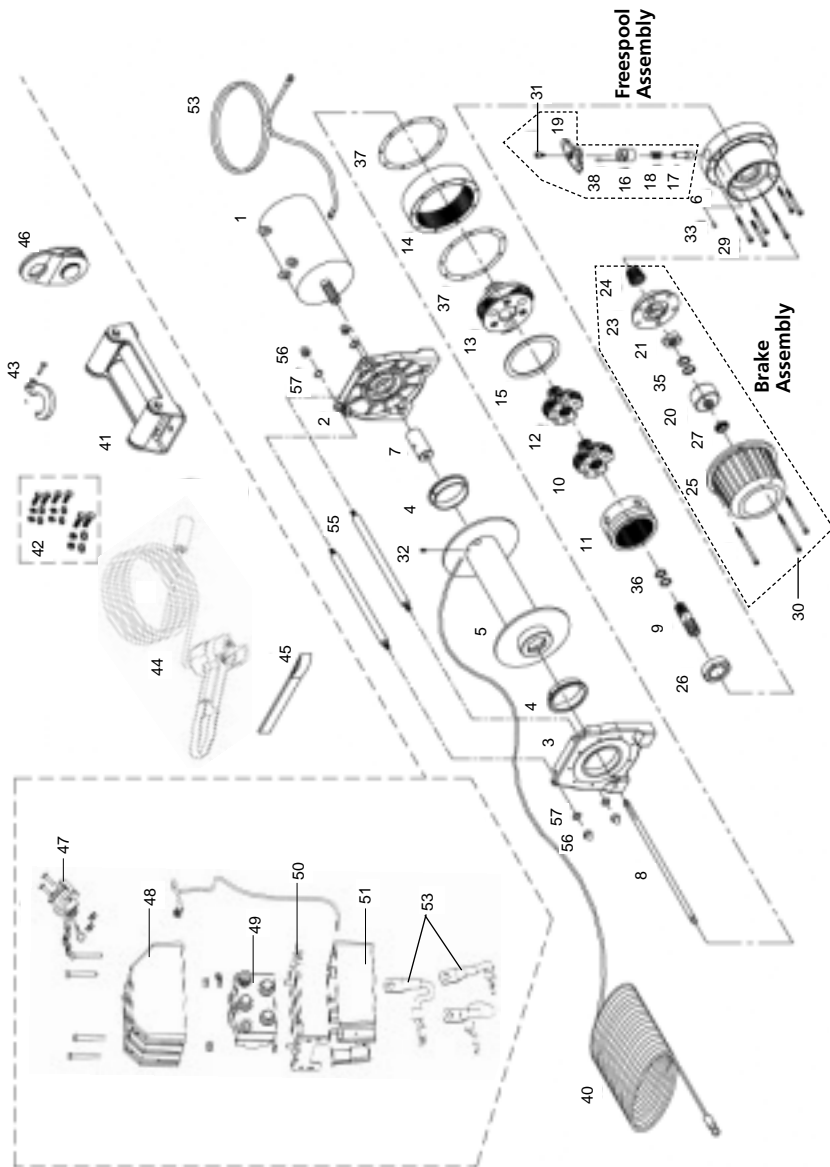

Figure 13

Reference Number	Description	Part Number	Qty
1	12 VDC Motor EP/Epi6.0	90-30500	1
	24 VDC Motor EP/Epi6.0	90-30501	1
	12 VDC Motor EP/Epi9.0	90-30502	1
	24 VDC Motor EP/Epi9.0	90-30503	1
2	Motor Support Rack	90-40500	1
3	Gear Support Rack	90-40501	1
4	Drum Bushing	90-14500	1
5	Drum (3" diameter on 09332 and 09334 only)	90-30517	1
6	Gear Box	90-30504	1
7	Connecting Socket	90-20500	1
8	1st Shaft	90-20501	1
9	1st Pinion	90-20502	1
10	1st Stage Carrier	90-30505	1
11	1st & 2nd Ring Gear	90-30506	1
12	2nd Stage Carrier	90-30507	1
13	3rd Stage Carrier	90-30508	1
14	3rd Ring Gear	90-30509	1
15	3rd Washer	90-20503	1
Freespool Assembly			
16	Clutch Sleeve	90-20504	
17	Clutch Lever		
18	Pressed Spring		
19	Clutch Knob		
38	Spring Pin		
Brake Assembly			
20	Brake Clutch Base	90-30510	
21	Brake Cam		
23	Cone Brake Disc		
24	Spiral Spring		
25	Brake Cover		
27	Bearing		
35	C-Rings (2 per assembly)		
Hardware Kit			
29	Hex. Bolt (6 per kit)	90-20513	1
30	Hex. Bolt (3 per kit)	90-14502	1
31	Hex. Bolt	90-20505	1
32	Hex. Bolt	90-20506	1
33	Hex. Bolt	90-30511	1
26	Bearing	90-14503	1
36	C-Ring	90-20507	1
37	Anit-leak Seal (2 included)	90-33450-01	1
40	Wire Rope	87-31120	1
41	Roller Fairlead	90-20508	1
42	Mounting Hardware	90-25048-01	1
43	Clevis Hook	90-41144	1
44	Remote Switch Assembly	90-14452	1
45	Handsaver Strap	90-14454	1
46	Snatch Block	90-24051	1
47	Remote Switch Socket	90-41145	1
48	Upper Solenoid Box	90-20511	1
49	Solenoid 12V	90-20509	1
	Solenoid 24V	90-14504	1
50	Solenoid Mounting Plate	90-14505	1
51	Lower Solenoid Box		
53	Motor Lead Wire Set		
55	Tie Bar		
56	Tie Bar Screw		
57	Spring Washer		

EPI SERIES WINCH ASSEMBLY

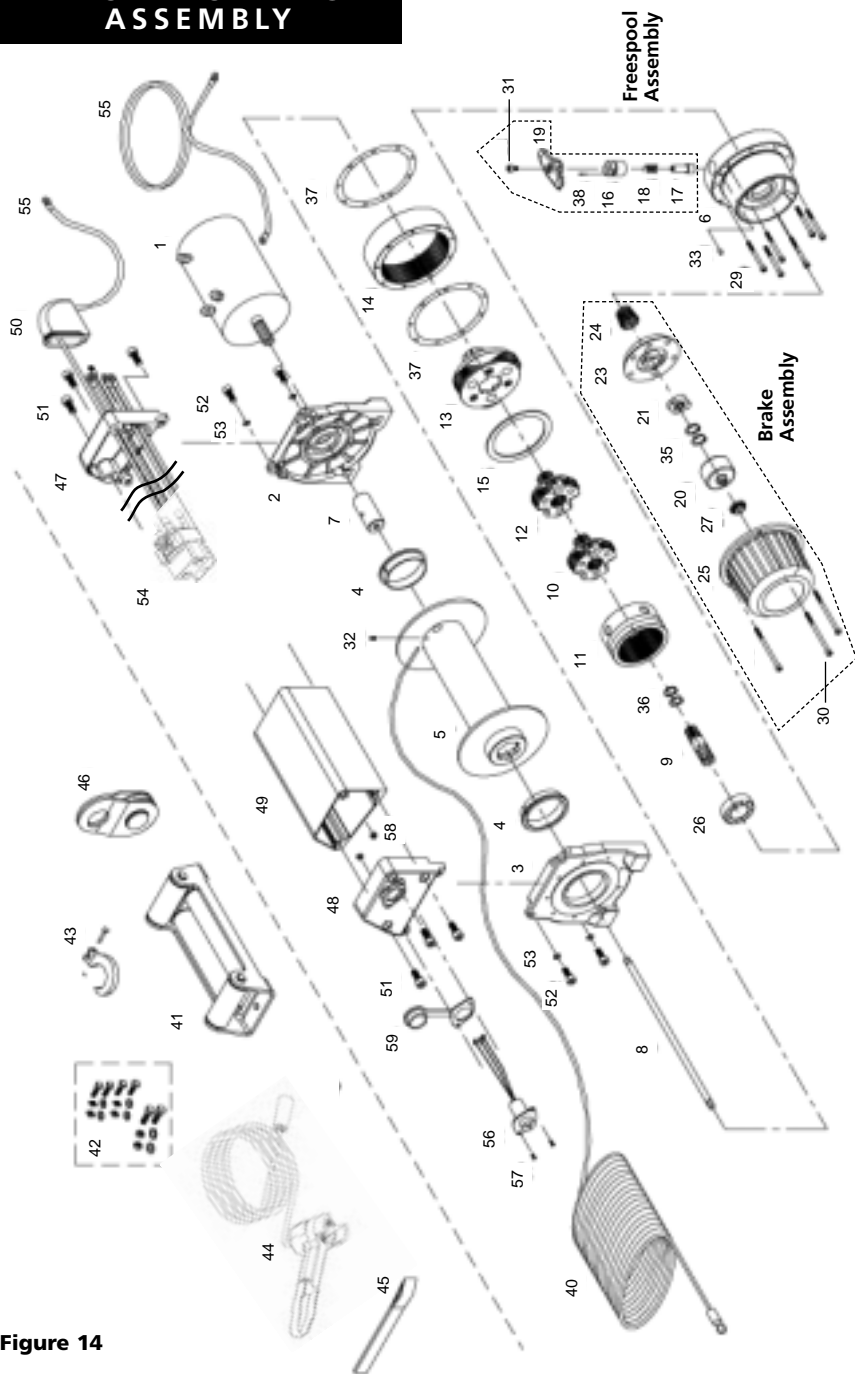

Figure 14

REPLACEMENT PARTS LIST

Reference Number	Description	Part Number	Qty
1	12 VDC Motor EP/Epi6.0	90-30500	1
	24 VDC Motor EP/Epi6.0	90-30501	1
	12 VDC Motor EP/Epi9.0	90-30502	1
	24 VDC Motor EP/Epi9.0	90-30503	1
2	Motor Support Rack	90-40500	1
3	Gear Support Rack	90-40501	1
4	Drum Bushing	90-14500	1
5	Drum (3" diameter on 09332 and 09334 only)	90-30517	1
6	Gear Box	90-30504	1
7	Connecting Socket	90-20500	1
8	1st Shaft	90-20501	1
9	1st Pinion	90-20502	1
10	1st Stage Carrier	90-30505	1
11	1st & 2nd Ring Gear	90-30506	1
12	2nd Stage Carrier	90-30507	1
13	3rd Stage Carrier	90-30508	1
14	3rd Ring Gear	90-30509	1
15	3rd Washer	90-20503	1
Freespool Assembly			
16	Clutch Sleeve	90-20504	
17	Clutch Lever		
18	Pressed Spring		
19	Clutch Knob		
38	Spring Pin		
Brake Assembly		90-30510	
20	Brake Clutch Base		
21	Brake Cam		
23	Cone Brake Disc		
24	Spiral Spring		
25	Brake Cover		
27	Bearing		
35	C-Ring		
Hardware Kit		90-14501	
29	Hex. Bolt		
30	Hex. Bolt		
31	Hex. Bolt		
32	Hex. Bolt		
33	Hex. Bolt		
26	Bearing	90-20513	1
36	C-Ring	90-14502	1
37	Anit-leak Seal (2 included)	90-20505	1
40	Wire Rope	90-20515	1
41	Roller Fairlead	90-30511	1
42	Mounting Hardware	90-14503	1
43	Clevis Hook	90-20507	1
44	Remote Switch Assembly	90-33450-01	1
45	Handsaver Strap	87-31120	1
46	Snatch Block	90-20508	1
47	Control Box Left Cover	90-30512	1
48	Control Box Right Cover	90-30513	1
49	Electric Box	90-30516	1
50	Rubber Clamp	90-20510	1
51	Hex. Bolt	90-14506	1
52	Hex. Bolt	90-14507	1
53	Spring Washer	90-14508	1
54	Solenoid 12V	90-14453	1
	Solenoid 24V	90-14455	1
55	Motor Lead Wire Set	90-20512	1
56	Remote Switch Socket	90-25058	1
57	Bolt	90-23032-22	1
58	Nut	90-23149-06	1
59	Rubber Cover	90-25046	1

TROUBLESHOOTING CHART

If a problem arises, contact your nearest Superwinch dealer or repair center.

Symptom	Possible Cause(s)	Corrective Action
Motor will not operate or runs in one direction only	<ol style="list-style-type: none"> 1. Damaged or stuck solenoid; most likely caused by not holding the inner nut to keep the stud from turning when attaching wire to solenoid 2. Switch inoperative 3. Broken wires or bad connection 4. Damaged motor 5. Solenoids not grounded 	<ol style="list-style-type: none"> 1. CAUTION: Disengage clutch before performing this test to prevent powering the wire rope drum. If a solenoid sticks once, it is likely to stick again and must be replaced immediately. Tap solenoid to free stuck contacts. Check by applying voltage to the small solenoid terminal. Be sure solenoid is grounded back to source. A solenoid that is not stuck will make an audible "click" when first energized 2. Replace Switch 3. Check for poor connections. CAUTION: Always use two wrenches (spanners). (See Figure 10) 4. Replace or repair motor 5. Check the ground path between battery negative and solenoid base
Winch will not shut off	<ol style="list-style-type: none"> 1. Solenoid stuck "on" 	<ol style="list-style-type: none"> 1. If solenoid sticks on, reverse direction and hold trigger switch on until the power lead can be disconnected. A safety on-off switch is available as an accessory
Motor runs extremely hot	<ol style="list-style-type: none"> 1. Long period of operation 2. Damaged motor 3. Damaged brake 	<ol style="list-style-type: none"> 1. Allow to cool 2. Replace or repair motor 3. Replace or repair brake
Motor runs but with insufficient power or line speed	<ol style="list-style-type: none"> 1. Weak battery 2. Battery to winch wire too long 3. Poor battery connection 4. Poor ground 5. Damaged brake 	<ol style="list-style-type: none"> 1. Recharge or replace battery. Check charging system 2. Use larger gauge wire 3. Check battery terminals for corrosion. Clean as required 4. Check and clean connections 5. Repair or replace brake
Motor runs but drum does not turn	<ol style="list-style-type: none"> 1. Clutch not engaged 	<ol style="list-style-type: none"> 1. Engage clutch
Winch runs backwards	<ol style="list-style-type: none"> 1. Motor wires reversed 2. Solenoids wired incorrectly 	<ol style="list-style-type: none"> 1. Recheck wiring 2. Recheck wiring
Will not hold load	<ol style="list-style-type: none"> 1. Excessive load 2. Worn or damaged brake 	<ol style="list-style-type: none"> 1. Reduce load or double line 2. Repair or replace brake

SUPERWINCH®

WARRANTY REPAIR CENTERS

USA

Superwinch Inc.
Winch Drive
Putnam, CT 06260
phone: 860-928-7787
repair@superwinch.com

Electric Motor Repair
2010 North 4th Street
Minneapolis, MN 55411
phone: 612-588-4693

Berens & Associates
124 Hegenberger Loop
Oakland, CA 94621
phone: 800-540-2858
berens94621@yahoo.com

Zorko's Alternator Service
241 Wells Road
Home, PA 15747
phone: 800-468-5055
zasapw@microserve.net

Electric Motors of Iowa City
50 Commercial Court
Iowa City, IA 52246
phone: 319-354-4040
emic4040@aol.com

CANADA

Demand Electric
228-39th St. N.E.
Calgary, AB T2E 2M5
403-230-2709

Harold Supply
3 Southerland Ave.
Sudbury, Ont. P3C 3A7
705-761-4455

Explora Industries Ltd.
9605-5th Ave.
Edmonton, AB T6E 0B2
780-430-8591

Dayworth Sales
1 Saunders Rd. Unit 2
Barrie, Ont. 9A7 9A7
705-726-7778

Les Equipment Twin
10401 Parkway Blvd.
Ville D'Anjou, PQ H1J 1R4
514-353-1190

Buffalo Industries
251-253 Princess Street
Winnipeg, Manitoba R2C 1M1
204-942-1951

Power Plus Tool Repair
57 Millenium Ave.
Moncton, NB E1E 2G2
560-855-8665

Muskoka Auto Parts
11 King William St.
Huntsville, Ont. P1H 2K8
705-789-2321

Lou Dennis Auto
Hiway 11 South
Sundridge, Ont. P0A 1Z0
705-384-5345

Outdoors Plus
128 Regional St.
P.O. Box 1349
Port Aux Basques, NF A0M 1C0
709-695-7533

Bobcaygeon Auto and Marine
91 Main St.
Bobcaygeon, Ont. K0M 1A0
705-738-2317

MAP Bracebridge
19 Taylor Rd.
Bracebridge, Ont. P1L 1W3
705-645-8785

MAP Fenelon Falls
165 Lindsay St.
Fenelon Falls, Ont. K0M 1N0
705-887-6232

Central Electric Motor Rewind
#1-1960 Windsor Rd.
Kelowna, BC V1Y 2Y3
250-860-4415
jnelsoncentral@netscape.net

Delta Tool Repair Limited
114-7533, 135th St.
Surrey, BC V3W 0N6
604-591-3230

Ted's Power Tool Repair
426-44th St. East
Saskatoon, SK S7K 0W1
306-934-6155

Bob's Electric Truck Service
845-B Macdonald Ave.
Regina, SK S4N 2X5
306-721-4148

Off Road Canada
251-12th St. "B" North
Lethbridge, AB T1H 2K8
403-327-7722

Gary's Starter & Alternator
P.O.Box 7 Site 4
RR 1 Mount Uniacke B0N 1Z0
Contact: Gary Thorne
902-757-2388

Power Blitz Mftg. & Maintenance
577 Edgeley Blvd. Unit 6
Concord, Ont. L4K 4B2
905-669-8209
ali@powerblitz.com

Bruce's Recreation
92 Balbo Dr.
Shoal Harbour Nfld A5A 4A8
709-466-3355

Atlantic Recreation & Marine
5 School St.
Sydney, Nova Scotia
B1S 3G1
902-567-1697
sbidart@thearm.ca

UNITED KINGDOM

Superwinch, LTD
Abbey Rise, Whitchurch road
Tavistock, Devon PL19 9DR
+44 (0) 1822 614101

WORLDWIDE Contact your Local Superwinch Distributor or call Superwinch.