

Water/Methanol Injection

**Boost
Cooler™**

INSTALLATION INSTRUCTIONS
FOR PART #50013
WATER / METHANOL INJECTION
SYSTEM
FORD POWERSTROKE
6.0L DIESEL



SNOW PERFORMANCE
COOLER, LIGHTER, FASTER™

CONTENTS

Kit Contents.....	3
Introduction.....	4
Nozzle Identification Chart:.....	4
Installation - Mechanical.....	5
Installation - Electrical.....	10
Variable Controller Installation.....	10
Controller Operation.....	11
Variable Controller Tuning.....	13
Boost Only Mode.....	13
Controller Operation Example.....	14
Testing the System.....	15
Tuning Quick Reference.....	16
Fluid Level Switch (optional).....	18
Solenoid Upgrade (optional).....	19
Install Notes.....	20



You must completely read through these instructions before installing and operating this product. Failure to do so can result in damage to this product and the vehicle.

Contact Us:

Phone Office (719) 633-3811
Fax (719) 633-3496
Tech Support Line (Toll Free) (866) 365-2762

Web <http://www.snowperformance.net>

Email sales@snowperformance.net
customerservice@snowperformance.net
tech@snowperformance.net

Mail
Snow Performance, Inc
213 Aspen Garden Way
Bldg. #1
Woodland Park, CO 80863

Notes

The contents of this document are subject to change without prior notice. No part of or this entire document may be reproduced in any form without prior written permission of Snow Performance, Inc under the copyright except for private use.

The names, addresses and telephone numbers mentioned are current as of August 22, 2007. Note that this information is subject to change. Please refer to www.snowperformance.net for current information.

LIFETIME WARRANTY

Snow Performance's commitment to providing the best water/methanol system is reflected in the Lifetime Warranty that is standard on all Snow Performance Boost Coolers™. We are able to offer this warranty due to our control of manufacturing quality and the historically high reliability of our products in the field.

Warranty Policy

Snow Performance, Inc. (hereafter "Snow") warrants that the Product shall conform to and perform in accordance with published technical specifications and shall be free of defects in materials and workmanship as long as :

The exclusive fluid used in the kit has been Snow performance's Boost Juice™ water methanol product as evidenced by sales receipts confirming purchases.

In the event that Boost Juice has not exclusively been used, A One Year Warranty applies.

In the event of failure, Snow will repair or replace the part at Snow's sole discretion. Failures resulting from misapplication or misuse of the Product, failure to adhere to any specifications or instructions, or failure resulting from neglect, abuse, accidents, or acts of nature are not covered under this warranty.

Warranty service may be obtained by delivering the part to Snow and providing proof of purchase. Customer agrees to insure the Product or assume the risk of loss or damage in transit, to prepay shipping charges to Snow, and to use the original shipping container or equivalent. Warranty is valid only for original purchaser and is not transferable. This Warranty gives you specific legal rights, and you may also have other rights which may vary from state to state.

This warranty applies to Snow manufactured Boost Cooler™ kits.

Non-Warranty Repair/Retest

Products returned due to damage or misuse and Products retested with no problem found are subject to repair/retest charges. A purchase order or credit card number and authorization must be provided in order to obtain an RMA (Return Merchandise Authorization) number prior to returning Product.

Kit Contents

Parts

1 150+ psi Pump
2 qt Reservoir
8 ft Red High Pressure Tubing
4 ft Black Wire Loom
Installation Instructions

Electrical Packet

In small bag:

2 Blue Butt Connectors
3 Small Eyehooks
1 Male Connector
3 Female Connectors
10 Tie Wraps
1 Armed Switch
3 in Double Sided Tape

Stage 3 Diesel Controller
Temperature Probe

Mechanical Packet

In small bag:

1 Nozzle Holder
2 3/8" NPT – 1/8" NPT Reducer Bushings
2 1/8" NPT – 1/4" Tube Elbow Fittings
7 #8x1&1/2" Screws
7 #8 Washers
1 #6x1/2" Screw

1 Dual Nozzle Upgrade
1 1/8" NPT Tap
1 Bulkhead
1 1/8" NPT to 1/8" Hose Barb
1 Yellow Temp Probe Connector
1 Temp Probe Compression Fitting – 3/16"
3 ft 1/8" Tygon Tubing
1 375ml/min nozzle
2 625ml/min nozzles

Introduction

- Please refer to system diagram during install. The optional fluid level switch (#40030) is shown.

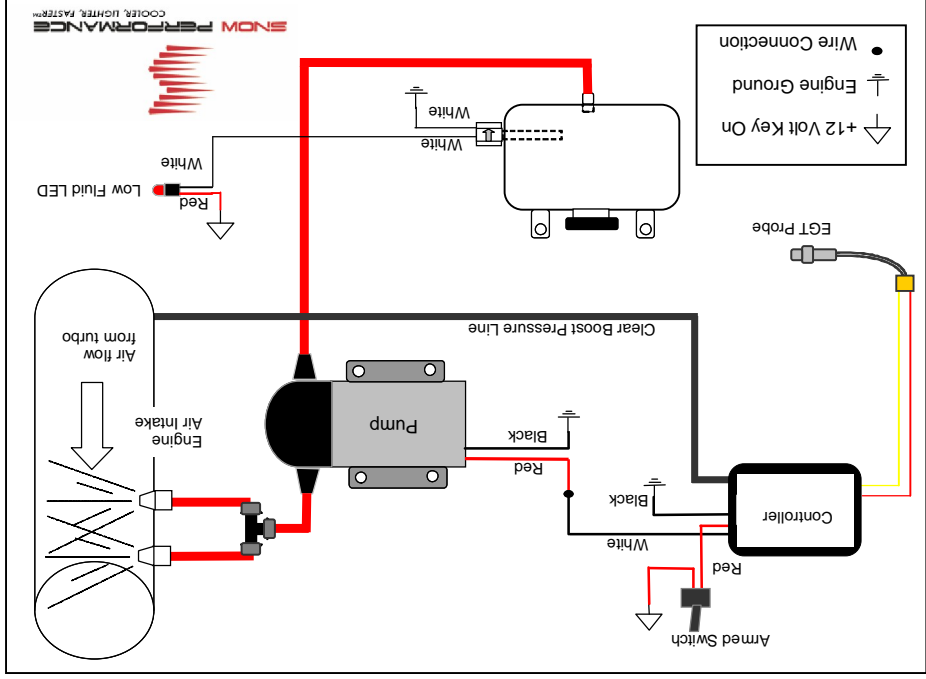

Nozzle Identification Chart:

Nozzle Color	Nozzle Size	Nozzle Color	Nozzle Size
Green	175 ml/min	Blue	625 ml/min
Black	100 ml/min	Red	375 ml/min
Yellow	60 ml/min	Purple	225 ml/min
			Nozzle Size

Disclaimer

Do not use this product until you have carefully read the following agreement. This sets forth the terms and conditions for the use of this product. The installation of this product indicates that the BUYER has read and understands this agreement and accepts its terms and conditions. Performance products by their nature are designed to increase horsepower and performance not engineered in the original vehicle and the increased stress could result in damage to related systems. This is a high performance product – use at your own risk. Snow Performance Inc., its agents, employees or owners shall not be under any liability whether in contract or otherwise whether or not resulting from our negligence or contents of information supplied for any damage or loss resulting from such information. The BUYER is responsible to fully understand the capability and limitations of his/her vehicle according to manufacturer specifications and agrees to hold the SELLER harmless from any damage resulting from failure to adhere to such specifications. The SELLER disclaims any warranty and expressly disclaims any liability for personal injury or damages. The BUYER acknowledges and agrees that the disclaimer of any liability for personal injury is a material term for this agreement and the BUYER agrees to indemnify the SELLER and to hold the SELLER harmless from any claim related to the item of the equipment purchased. Under no circumstances will the SELLER be liable for any damages or expenses by reason of use or sale of any such equipment. The BUYER is responsible to obey all applicable federal, state, and local laws, statutes, and ordinances when operating his/her vehicle, and the BUYER agrees to hold SELLER harmless from any violation thereof. The SELLER assumes no liability regarding the improper installation or misapplication of its products. It is the installer's responsibility to check for proper installation and if in doubt, contact the manufacturer.

Install Notes

Pump Setting _____(psi)

Nozzle Size _____(ml/min)

Controller Setting _____

Misc:

Installation - Mechanical

Step 1 Reservoir Install

Mount reservoir as high in engine compartment as possible using #8x1½" sheet metal screws and washers provided.

Optional: The factory windshield washer reservoir can be used as the reservoir for your system.



Washer Tank With Bulkhead Fitting

- Drill 9/16" hole in desired bulkhead location.

- Remove one nut from and turn the remaining nut until it is at the very end of the bulkhead.

- Feed red tubing through the drilled hole and up and out of the top of the reservoir.

- Attach red tubing to the bulkhead on the side opposite the nut.

- Pull the tube through the bulkhead hole until the bulkhead seats against the inside of the reservoir.

- Apply liberal amount of methanol resistant sealant around bulkhead.

- Slide the nut you had previously removed up onto the tube and thread it onto the bulkhead.

- While pulling firmly on the red tubing, tighten the outer nut using a 17mm socket (only needs to be hand tight).

- Once sealant has set, fill reservoir with water and check for leaks.

TECH TIP You can mount the tank in the rear of the vehicle. The pump is a pusher type by design so it needs to be mounted as close to the reservoir as possible. Because the pump is oversized, injection pressure will not be affected. A Solenoid Upgrade is recommended for rear mounted reservoirs.

Step 2 Pump Install

Install 3/8" to 1/8" reducer bushing using GOOP sealant on threads. Tighten 2-3 turns past hand tight. Install 1/8" elbow fitting into bushing using GOOP sealant on threads. Tighten 2-3 turns past hand tight. Mount pump so the pump inlet is positioned at the lowest point of the reservoir or lower. Pump can be mounted horizontally or vertically using (4) supplied #8x1 1/2" screws and washers.



Pump Mounted Behind Front Bumper

Measure the distance from the reservoir outlet to the pump inlet. Cut the 1/2" red tubing using utility knife. Make cuts are as square as possible.

Ensure there are no kinks in the tubing and insert tubing into quick disconnects at pump and reservoir until fully seated. If using the optional rear mounted 8 Gallon Reservoir (#40010), the pump must also be rear mounted. Typical mounting locations are below the bed or along the frame rail. The pump is weather proof and can withstand normal roadway conditions.

Solenoid Upgrade (optional)

The optional Solenoid Upgrade (#40060) is required if the nozzle is to be installed after the intake throttle plate, or the fluid reservoir is mounted higher than the nozzle.

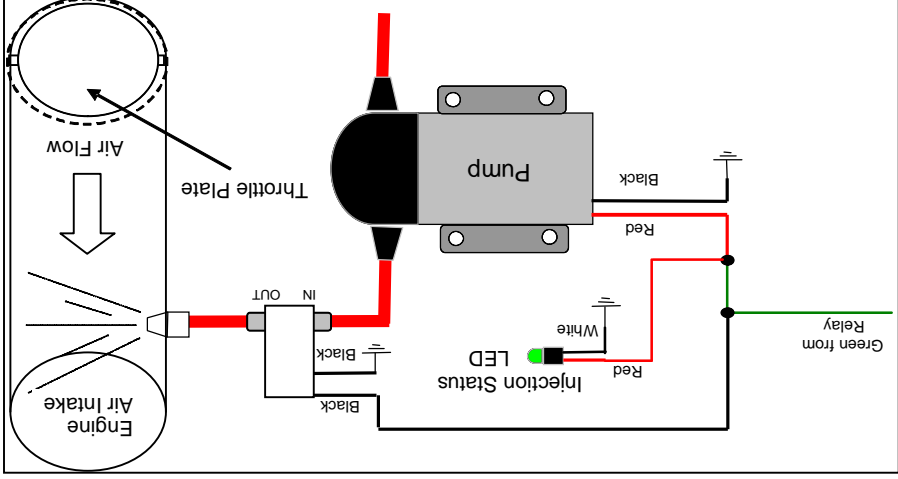

Hand thread the two 1/8" NPT quick connect fittings into ports labeled IN and OUT on the solenoid. Tighten an additional half turn.

Cut high pressure line at location solenoid is to be installed. Insert ends of cut line into quick connect fittings of solenoid. The port labeled IN is the inlet and the port labeled OUT is the outlet. Firmly pull on line to check secure connection. If line pulls out, re-insert farther into fitting to engage locking clips. If high pressure line removal is required, firmly press in plastic fitting ring to disengage locking clips while pulling hose from fitting.

Connect one of the BLACK wires from solenoid to the RED positive pump wire. Note that connecting the wire to any other power source other than the pump wire will result in improper operation of solenoid. Connect the second BLACK wire to a secure chassis ground location.

Fluid Level Switch (optional)

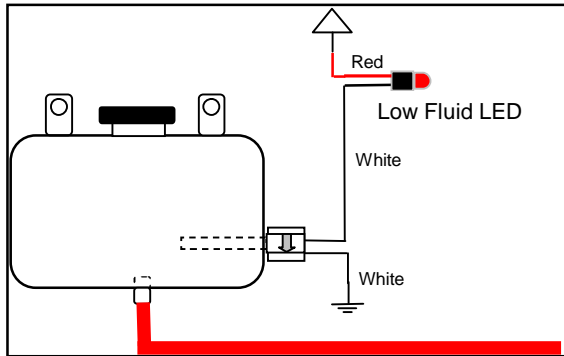

Instructions

- After mounting reservoir, mount red LED in dash next to the green "injection" LED is usually easiest.
- Wire LED per diagram with Red wire to a 12v key on source, and the White wire to one of the White wires of the level switch.
- Connect other White wire of the level switch to vehicle ground.
- With key-on source enabled, the red LED should be "on" with no fluid in the reservoir. Upon filling the reservoir, the red LED should be "off".

TECH TIP The level switch is designed to indicate when there is less than 1" of fluid in the reservoir.

Step 3 Nozzle Selection

Nozzle sizing is a function of horsepower, which approximates the engine airflow, and boost, which approximates intake charge heat.

Recommended starting points:

250 - 300 RWHP	625ml/min nozzle
325 - 400 RWHP	375 & 625ml/min nozzle
450 - 650 RWHP	2 - 625ml/min nozzle

TECH TIP Seal the nozzle into the nozzle holder using GOOP sealant. Using a sealant that is not permanent will allow for nozzle changes during tuning. Simply remove the nozzle, clean the threads, and reinstall using sealant.

Assemble desired nozzle into nozzle holder using methanol resistant sealant. **The end of the nozzle with the fine mesh screen is to be inserted into the nozzle holder.** Torque at least 1/2 turn past hand tight.



Correct



Incorrect

NOTE: If nozzle is mounted lower than the reservoir, a Solenoid Upgrade (#40060) must be used to prevent draining.

Step 4 Nozzle Mounting

The nozzle assembly should be installed 90° to the direction of airflow. On round intake tubes, this is 360° around the tube meaning the nozzle can be mounted in any direction. This will ensure maximum cooling as the nozzle sprays in a cone pattern. Choose and mark mounting location on air intake for nozzle placement.

Remove the inlet piece just before the intake and drill and tap (1/32" pre-drill, 1/8"-27 NPT tap) for two nozzles. While the inlet piece is removed, drill and tap a third hole for the 1/8" NPT to 1/8" hose barb fitting. This will be the dedicated boost source for the controller.

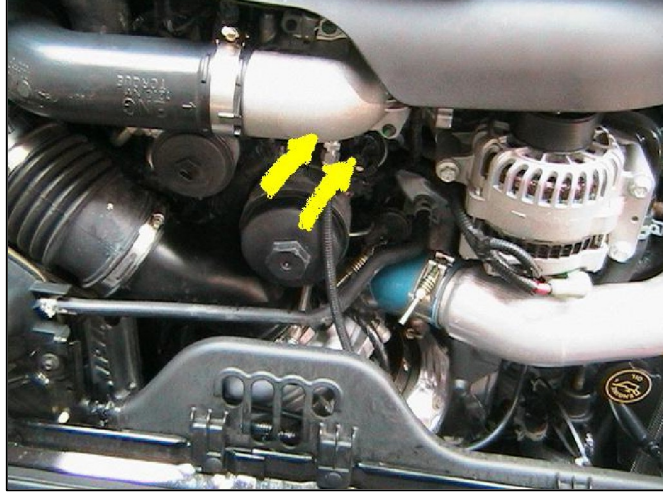

The nozzle is mounted into the intake using its external 1/8 NPT threads. Tighten the nozzle and nozzle holder assembly one half turn past hand tight using methanol resistant sealant to seal the threads.

Maintenance – Remove nozzle(s) and clean screen filters at least once per year using carb cleaner.

The Boost Cooler® has been designed to operate with high concentrations of methanol. Oil or other additives are not required for system lubrication.

For best performance, cooling and system life it is recommend that Snow Performance Boost Juice™, #40008, be the exclusive fluid used in the system.

Tuning Quick Reference

If combustion quench occurs as evidenced by engine “bucking”, reduce the injection quantity. This can be done by:

1. Lowering the pump pressure by turning the pump regulator adjusting screw counterclockwise.
2. Using a smaller nozzle(s).
3. Using Screen 10 and Screen 11 to adjust the gain.

Also, fresh methanol – less than 1 month old when exposed to atmosphere – and using a greater methanol concentration – up to 50% - will reduce combustion quench.

100% water will cool combustion and EGTs and will increase power approx 20-30 HP.

75/25 water/methanol will reduce EGTs and power will increase approximately 40 HP.

50/50 water/methanol will reduce EGTs and increase power approximately 70+ HP.

Caution: To avoid “pooling” in the intake and possible engine damage upon start-up, it is recommended that:

1. The engine be run without water/methanol for at least 5 minutes after injection before turning the engine off.
2. The “armed switch” is turned to the off position when the engine is off.

Caution: The use of methanol with propane is not recommended due to their similar combustion characteristics. Using both could induce diesel “knock” and cause head gasket problems. For this reason, 100% water is recommended when using this system in conjunction with propane.

Step 5 Nozzle Connection

Measure the distance from the pump outlet to the nozzle holder.

Cut the ¼” red tubing using utility knife. Make cuts are as square as possible.

Ensure there are no kinks in the tubing and insert tubing into quick disconnects until fully seated.

Gently pull on tubing to ensure a good connection.

Use tie wraps to help route tubing and to ensure it doesn't contact moving or hot parts in the engine compartment.

Step 6 Install EGT Probe

Drill and tap (7/16” predrill, ¼” NPT Tap) exhaust manifold pre-turbo. If this is performed with the exhaust manifold still on the engine, start the engine and let it idle while drilling and tapping. This will prevent shaving from entering the exhaust and turbo. During tapping, coat tap with heavy grease so it will collect any metal shavings.



Mount the Temp Probe using the 3/16” compression fitting (provided).

Installation - Electrical

Variable Controller Installation



Attach controller to secure location with easy access in driver's compartment using supplied tape. Connect Tygon tubing from intake plenum to clear tubing coming from the controller and secure with a tie wrap. Your controller has an internal self resetting fuse such that an external automotive type fuse is not required. In the case of a fault, the internal fuse will attempt to reset after one minute of power off.

CAUTION: Disconnect the negative battery terminal while connecting wires to prevent electrical fire or damage to controller.

- Connect WHITE wire to Pump RED power wire.
- Connect RED wire to +12V key on source with inline switch. When selecting a 12V key on source, try to find a dedicated circuit with at least a 15 AMP fuse (25 AMP with 220psi pump).
- Connect BLACK wire to a good ground location.
- Wire the Yellow "K" type temp probe connector to temp probe installed in Step 6 above. The YELLOW wire connects to the POSITIVE terminal, the RED wire connects to the NEGATIVE terminal of the connector. Connect to the lead from control module.

TECH TIP Always insure to have a good electrical ground connection. Poor ground will result in erratic operation of controller.

Testing the System

Step 1 Test Pump and Mechanical System

Disconnect pump from controller. Using a 12 volt source, apply power to red wire of pump. Pump should activate and fluid level in tank should go down. It is recommended to also check the nozzle spray pattern while following this procedure. Also check for leaks.

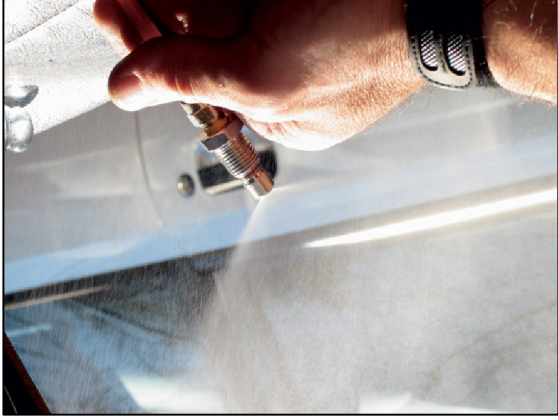

If pump goes on and fluid level doesn't go down, there is an obstruction in the tube or nozzle.

Activation of pump for short periods (2 - 5 sec.) will not cause engine damage.

Step 2 Test Controller

- With the nozzles removed from the intake, place the controller in "boost only" mode by disabling the EGT Control mode. Set gain to 100.
- Disconnect the Tygon boost line from the hose barb at the intake.
- Using an air compressor, apply 10-20 psi of pressure to the boost line.
- Pump should activate, fluid should flow, and tank level should go down.

Controller Operation Example

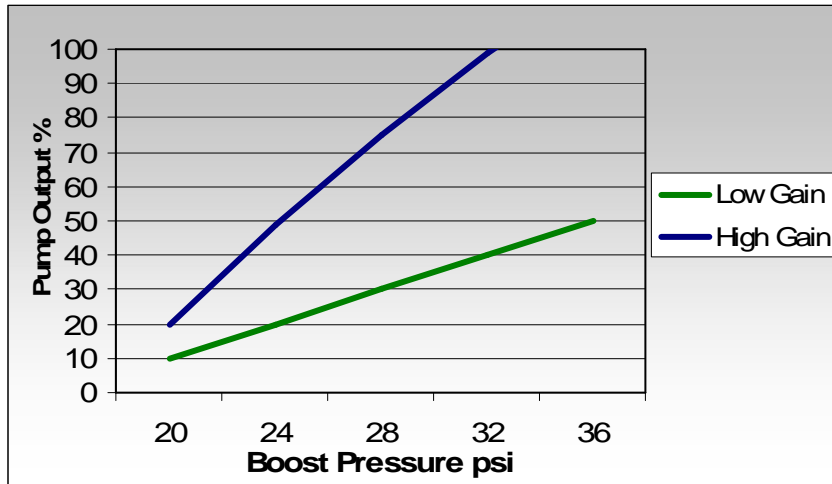

The above chart is an example of the effect of different gain settings for the water/methanol injection controller. When in boost control mode, a higher gain setting will increase the injection rate faster than a low gain setting for a specific amount of boost pressure measured.

When EGT Control mode is enabled, the 3D controller will measure EGTs and boost pressure to calculate the injection rate. In this mode, a high gain setting will result in a larger injection rate.

Controller Operation

The controller has an LCD display screen. The display software allows for seven different display “modes” and three control/setup screens.

To control the screen selection, the unit has two operator buttons; one to the left of the screen (Button 1) and one to the right of the screen (Button 2). Pressing and releasing Button 1 will cause the display to sequence to the next mode. Button 2 is only active in the control/setup screens, and is used to change the current control setting of the setup screen displayed.

The system memory will remember the current display setting even if the unit is turned off. The controller will turn on at the last used display setting.

Additionally, Button 2 is used for the “Injection ON/OFF” function.

Pressing and holding Button 2, then pressing Button 1, then releasing both buttons will change the system to read only without changing the display screen. All screen display functions will remain active even when the injection is turned off.

Screen 1

This mode displays Boost Pressure (P), Temperature (T) and Injection percentage (I) as three independent bar graphs. The pressure scale is scaled proportional to the Lo/Hi boost selection.

Screen 2

This mode displays the boost pressure and EGT temperature in PSI and °F.

Screen 3

This mode displays the boost pressure and EGT temperature in BAR and °C.

Screen 4

This mode displays the boost, EGT and injection in English units.

Screen 5

This mode displays the boost, EGT and injection in Metric units

Screen 6

This display shows both digital and bar graph readings for boost and EGT in English units.

Screen 7

This display shows both digital and bar graph readings for boost and EGT in Metric units.

Screen 8

This is the setup screen for the "Boost Only" control mode. Pressing the right Button (button 2) will toggle the setting between ON and OFF. If the "EGT Control" is ON, the matrix value for the injection is used. If the "EGT Control" is OFF, the "Boost Only" injection setting will be used. The selection of this function is also stored in system memory and recalled on power on.

Screen 9

This screen is used to select between LOW, MED, and HI boost mode. For vehicles making 8-18 psi of boost, use LOW mode. For vehicles making 18-25 psi of boost, use MED mode. For vehicles making 25+ psi of boost, use HI mode.

Screen 10

This screen is used to increase the injection gain setting. Pressing and releasing Button 2 will increase the gain setting. This setting is also remembered on power up.

Screen 11

This screen is used to decrease the injection gain setting. Pressing and releasing Button 2 will decrease the gain setting. This setting is also remembered on power up.

Variable Controller Tuning

EGT Control Mode

When EGT Control mode is enabled, the controller will measure EGTs and boost pressure to calculate the injection rate. In this mode, a high gain setting will result in a larger injection rate.

- Toggle to Screen 8. Set EGT Control to ON.
- Toggle to Screen 10. Adjust the gain up to 100.
- If combustion quench occurs as evidenced by engine "bucking", reduce the injection quantity or lower the gain setting on the module. This can be done by:
 - Lowering the pump pressure by turning the pump regulator adjusting screw counterclockwise.
 - Using a smaller nozzle(s).
 - Adjust the gain.
- To adjust gain down, toggle to screen 11. Adjust the gain down until engine runs smooth with no bucking.

Boost Only Mode

The controller has a "boost only" mode. When EGT Control mode is disabled, injection is a function of boost pressure only which is desirable in racing applications where more immediate injection is desired.

- Toggle to Screen 8. Set EGT Control to OFF.
- Toggle to Screen 10. Adjust the gain up to 100.
- If combustion quench occurs as evidenced by engine "bucking", reduce the injection quantity or lower the gain setting on the module. This can be done by:
 - Lowering the pump pressure by turning the pump regulator adjusting screw counterclockwise.
 - Using a smaller nozzle(s).
 - Adjust the gain.
- To adjust gain down, toggle to screen 11. Adjust the gain down until engine runs smooth with no bucking.