

# SPECTRE®

## Performance

### Intake Installation Instructions P/N 9070 (red filter) - P/N 9070B (blue filter) P/N 9070K (black filter)

#### Year/Make/Model/Engine

2015-17 Ford Edge 3.5L

NOT LEGAL FOR SALE OR USE ON ANY POLLUTION CONTROLLED MOTOR VEHICLE IN CALIFORNIA OR STATES ADOPTING CALIFORNIA EMISSION PROCEDURES.

See Spectreperformance.com for CARB status on each part for a specific vehicle



#### Parts List

- 1- Intake tube
- 1- Heat shield
- 1- Air filter
- 1- Velocity Stack
- 1- Edge Trim
- 1- 3" Coupler
- 1- 3" Flex Coupler
- 1- 6" Hose Clamp
- 4- 3" Hose Clamp
- 1- Plug
- 1- Bracket
- 1- M6 Bolt
- 2- M6 Flat Washers
- 1- M6 Nylock Nut
- 1- 3/8" Hose

#### Tools Required:

- 5/16" or 8mm Nut driver
- 7mm Nut driver
- Phillips screwdriver
- Flat blade screwdriver
- 10mm socket
- 10mm wrench
- Extension
- Ratchet

For filter reorders ask at the special order counter of your local parts store or call:  
1-909-673-9800

ask for: P/N HPR9606 (red filter)  
P/N HPR9606B (blue filter)  
P/N HPR9606K (black filter)



### Step 1

**Safety first!** Before you begin the installation, make sure that the vehicle is in park (or neutral for a manual transmission) with the parking brake set. Disconnect the negative battery terminal and verify that all components that are listed are present. **Note:** This kit was designed and tested on a stock engine without any custom tuning done to the engine computer. Removing the battery cable may erase the programmed radio stations. The anti-theft code will need to be entered into some radios after the battery cable is connected. The anti-theft code can typically be found in the owner's manual or at your local dealership.

---



### Step 2

Disconnect the quick disconnect vent hose by pressing the gray release tab. Release the wiring harness from the intake tube by pulling the plastic tab out of the intake tube. Disconnect the second vent hose by pulling out the 90 degree plastic fitting out of the intake tube.



### Step 3

Loosen the hose clamps securing the stock intake tube to the throttle body and air box. Then remove the stock intake tube from the vehicle.

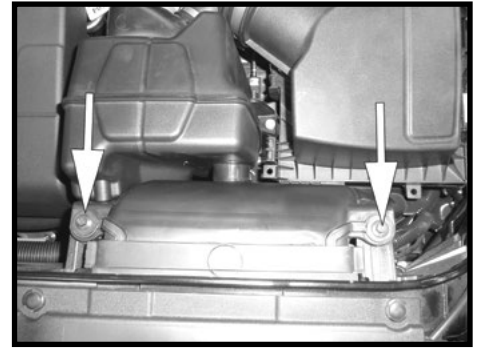

### Step 4

Remove the 2 screws securing the fresh air duct to the cowl.

---

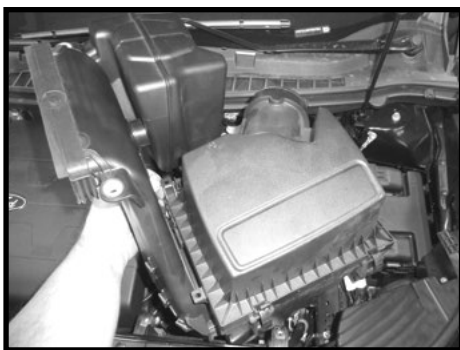

### Step 5

Remove the stock air box assembly by pulling up on the air box to release it from the mounting grommets.

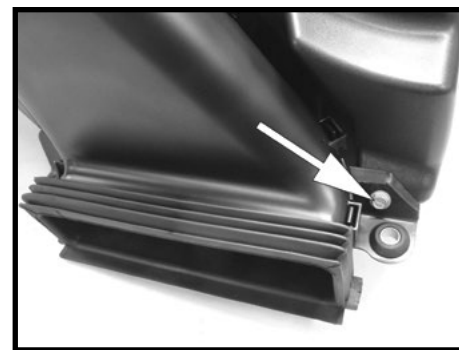

### Step 6

Remove the 2 screws securing the intake resonator chamber to the stock air box. Then remove the resonator.

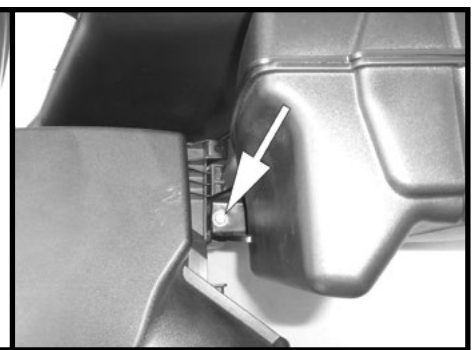

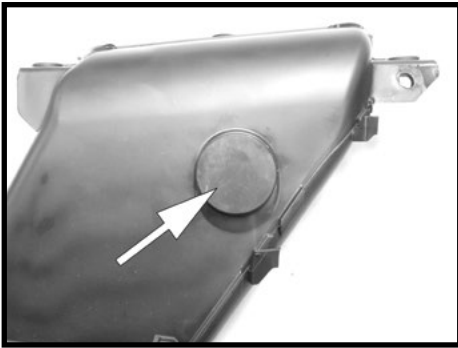

**Step 7**  
Install the provided plug into the hole from the resonator into the fresh air duct.

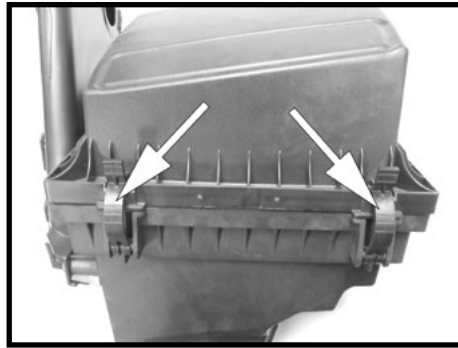

**Step 8**  
Unclip the air box top retaining clips and remove the air box top and stock air filter.



**Step 9**  
Reinstall the stock air box base and secure the fresh air duct to the cowl using the stock hardware.



**Step 10**  
Install the 3" flex coupler onto the throttle body and secure with the provided hose clamp. Install the second hose clamp but leave it loose for now.

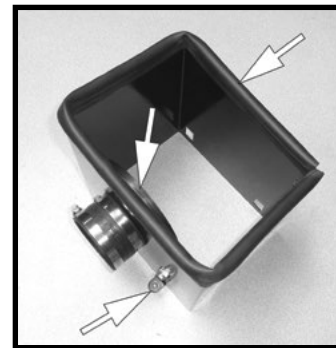

**Step 11**  
Install the provided edge trim onto the top edge of the heat shield as shown. Install the bracket onto the heat shield using the supplied hardware. Install the velocity stack into the hole in the heat shield and secure it with the provided coupler and hose clamp.

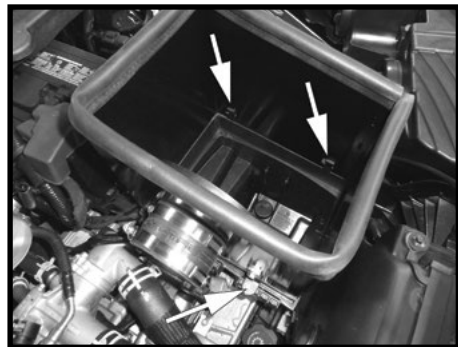

**Step 12**  
Install the heat shield into the base of the stock air box and secure with the stock retaining clips. Then secure the bracket to the air box base using the stock screw removed in step 6.

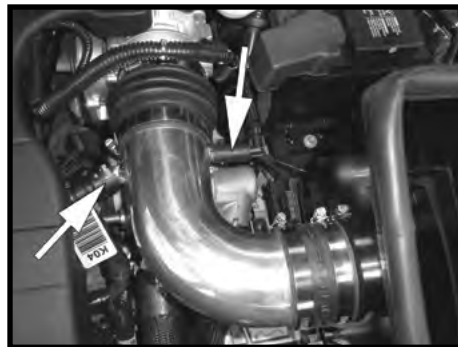

**Step 13**  
Install the intake tube into the coupler at the throttle body and then into the coupler at the heat shield and secure it in place with the hose clamps. Reconnect the quick disconnect vent hose onto the intake tube quick disconnect fitting. Reconnect the second vent hose onto the nipple on the intake tube by using the provided 3/8" hose on the stock plastic 90 degree fitting.

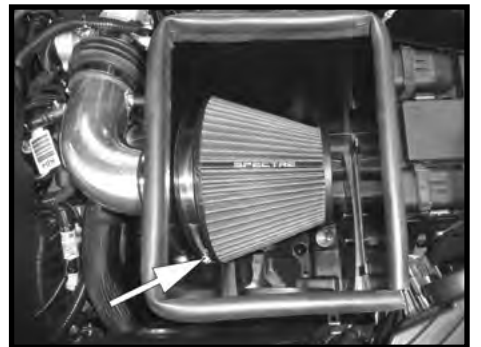

**Step 14**  
Install the air filter onto the velocity stack and secure with the provided hose clamp.

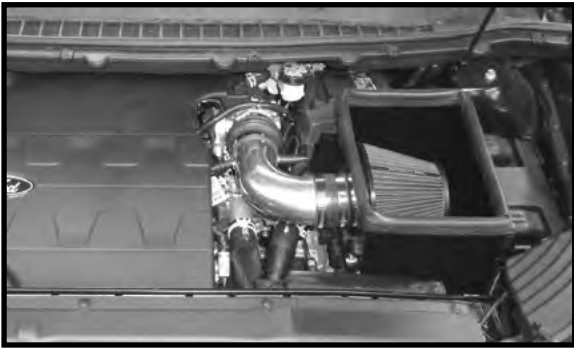

**Step 15**

**Make sure that all clamps and hardware are fully tightened. Reconnect the battery cable, start the vehicle and let it warm up. Shut off and inspect the installation once more for any loose clamps, wires, or hardware. Test drive & enjoy! Your installation is now complete. Periodically check all clamps and brackets.**

**If you need any assistance please call 1-800-858-3333 to speak with a representative in our Customer Service Center before returning the product.**

 **WARNING** This product can expose you to a chemical or chemicals known to the State of California to cause cancer and birth defects or other reproductive harm.

**NOT LEGAL FOR SALE OR USE ON ANY POLLUTION CONTROLLED MOTOR VEHICLE IN CALIFORNIA OR STATES ADOPTING CALIFORNIA EMISSION PROCEDURES.**

See [Spectreperformance.com](http://Spectreperformance.com) for CARB status on each part for a specific vehicle

**SPECTRE**<sup>®</sup>  
*Performance*

(909) 673-9800

[www.spectreperformance.com](http://www.spectreperformance.com)

© 2017 SPECTRE PERFORMANCE Made in China

176283  
8/23/17