

**FLAMING  
RIVER**

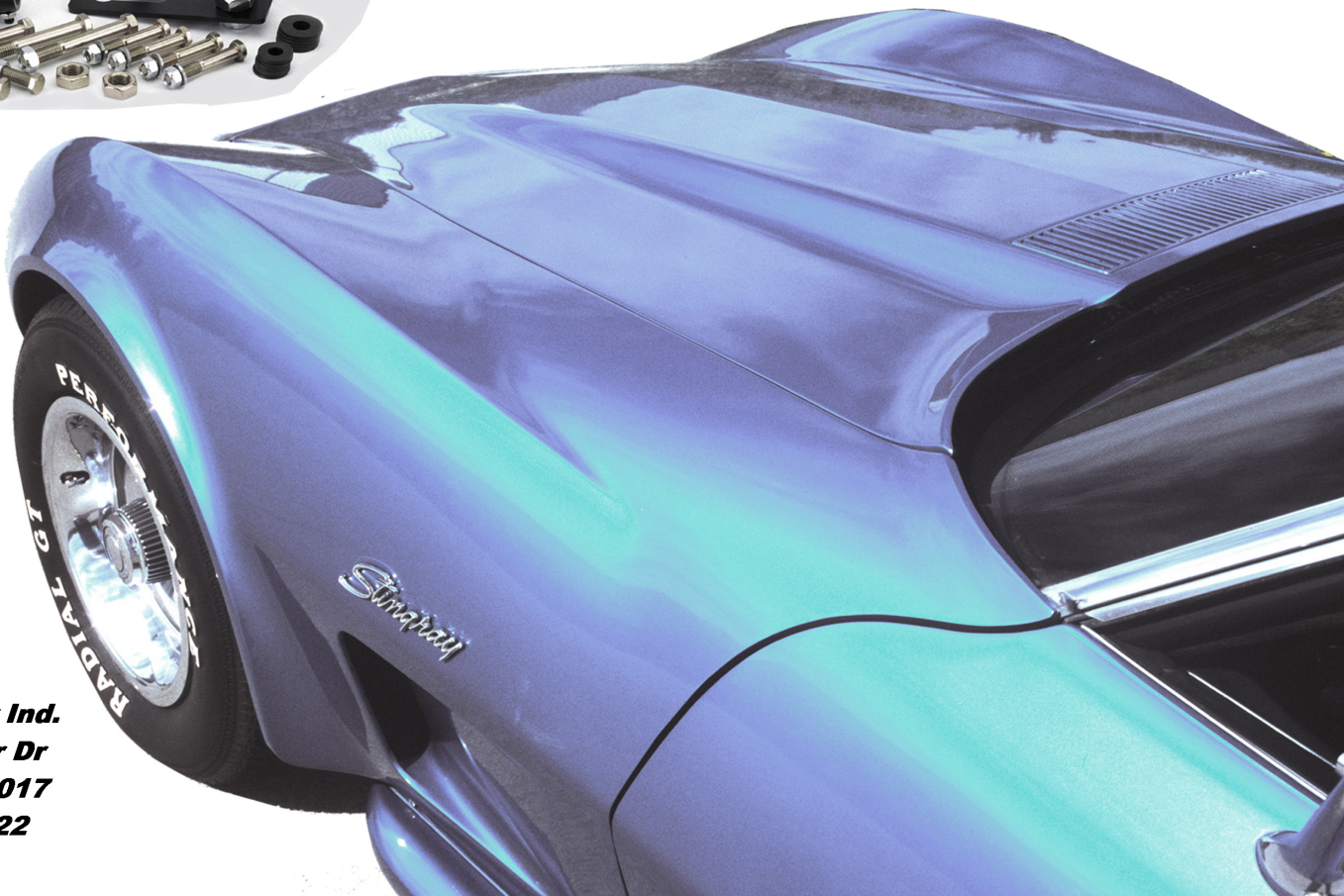

***1963-1982 Corvette  
Manual Rack &  
Pinion Conversion Kit***

***FR312KT***



**Flaming River Ind.  
800 Poertner Dr  
Berea OH 44017  
800-648-8022**

## Index

**NOTE:** Before beginning you must first measure the width of your front end from LEFT outer tie rod end zerk (grease) fitting to the RIGHT outer tie rod end zerk fitting to determine the overall width of your front end. Write dimension here for further reference \_\_\_\_\_

**Installation hardware and inventory** PG 2

### **Section 1 Original System Removal**

A. Steering Box & Linkage Removal PG 3

### **Section 2 Installation of The Flaming River Rack & Cradle**

A. Installation of Rack and Cradle PG 4

### **Section 3 Universal Joint Installation**

A. Universal Joint and Steering Shaft Installation PG 5-6

**Torque Specs** PG 6

**Template** PG 7

**IMPORTANT!!** For safety, before starting, disconnect both battery cables and ensure the vehicle is properly supported by jack stands.

**We recommend** that you always install new outer tie rod ends when installing this kit.

**We highly recommend** a professional alignment to set the proper alignment settings.

#### **Warranty Disclaimer**

Because of their intended usage, the manufacturer makes no warranties whatsoever expressed or implied, oral or written, to purchasers of their products regarding performance, safety, fit, merchantability or length of service. Purchasers are responsible for selection of proper goods and must rely on their own skill or judgment that such goods are suitable for the purchaser's application.

## Installation Hardware and Inventory

<u>Qty</u>	<u>Part Number</u>	<u>Description</u>
1	BK10300	Vette Support Bearing Bracket
3	Bolt 3/8-16x1.25	3/8-16 Grade 8 Bolt 1.25" Long
2	Bolt 3/8-16x1.5	3/8-16 Grade 8 Bolt 1.5" Long
6	Cbolt 3/8-16x4.5	3/8-16 Carriage Bolt 4.5" Long
1	FR1.75 Saw	1 3/4" Hole Saw
1	FR1507-3Q-8	Corvette Manual Rack
1	FR1507C	Omni Style Clamp with Bushing
1	FR1709DD	9/16-26 x 3/4" DD U-joint (Rack)
1	FR1712DD	1"-48 x 3/4"DD U-joint (Column)
1	FR1716DD	3/4"DD x 3/4"DD U-joint (Center)
1	FR1810	Support Bearing
1	FR1850	18" DD Shaft
1	FRVTM1	Vette Cradle
11	Nut 3/8-16	Lock Nut 3/8-16
2	Nut 5/8-18	Jam nut 5/18-18 Grade 8
16	Wash 3/8	3/8 Flat Washer

## Steering Box and Linkage Removal

- 1) Remove the pinch bolt that retains the rag joint (B-2) to the steering box.
- 2) Remove the pitman arm from the steering box (C) using a pitman arm puller.
- 3) Remove the two bolts that retain the idler arm to the frame rail.
- 4) Remove the cotter pins and castle nuts and separate the outer tie rod ends from the spindles.
- 5) Next remove the steering linkage (D) from the car.
- 6) If you have power steering remove the lines from your power box, pump and pump brackets. A shorter belt may need to be installed.
- 7) Remove the three bolts that retain the box to the frame rail and remove the box from the car.

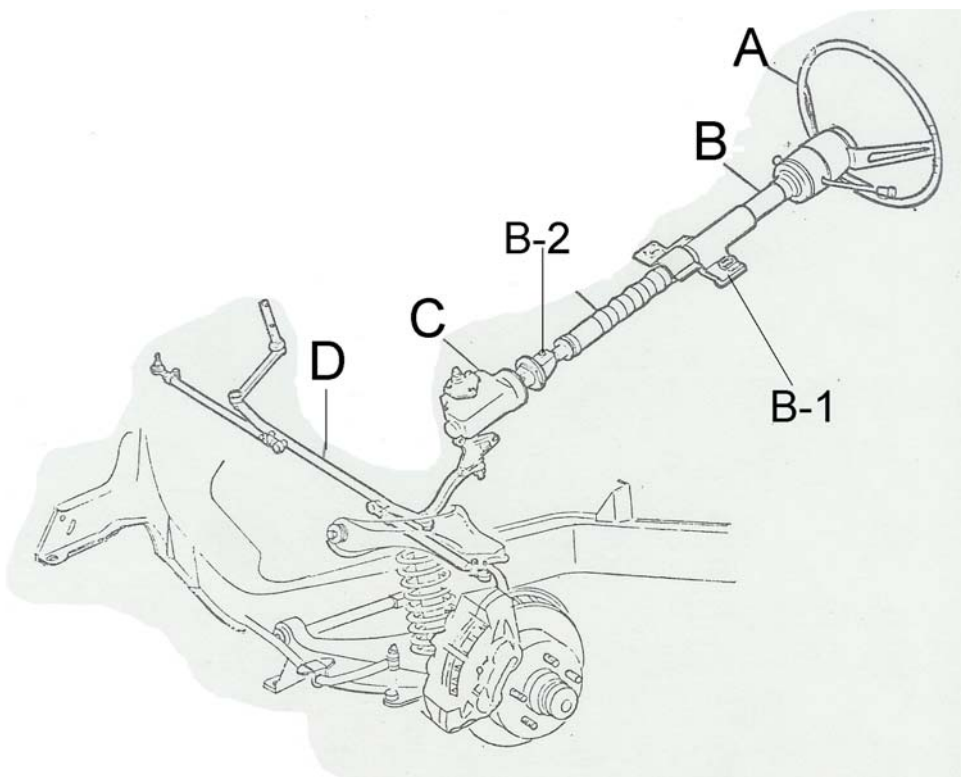

## Installation of Flaming River Rack & Pinion

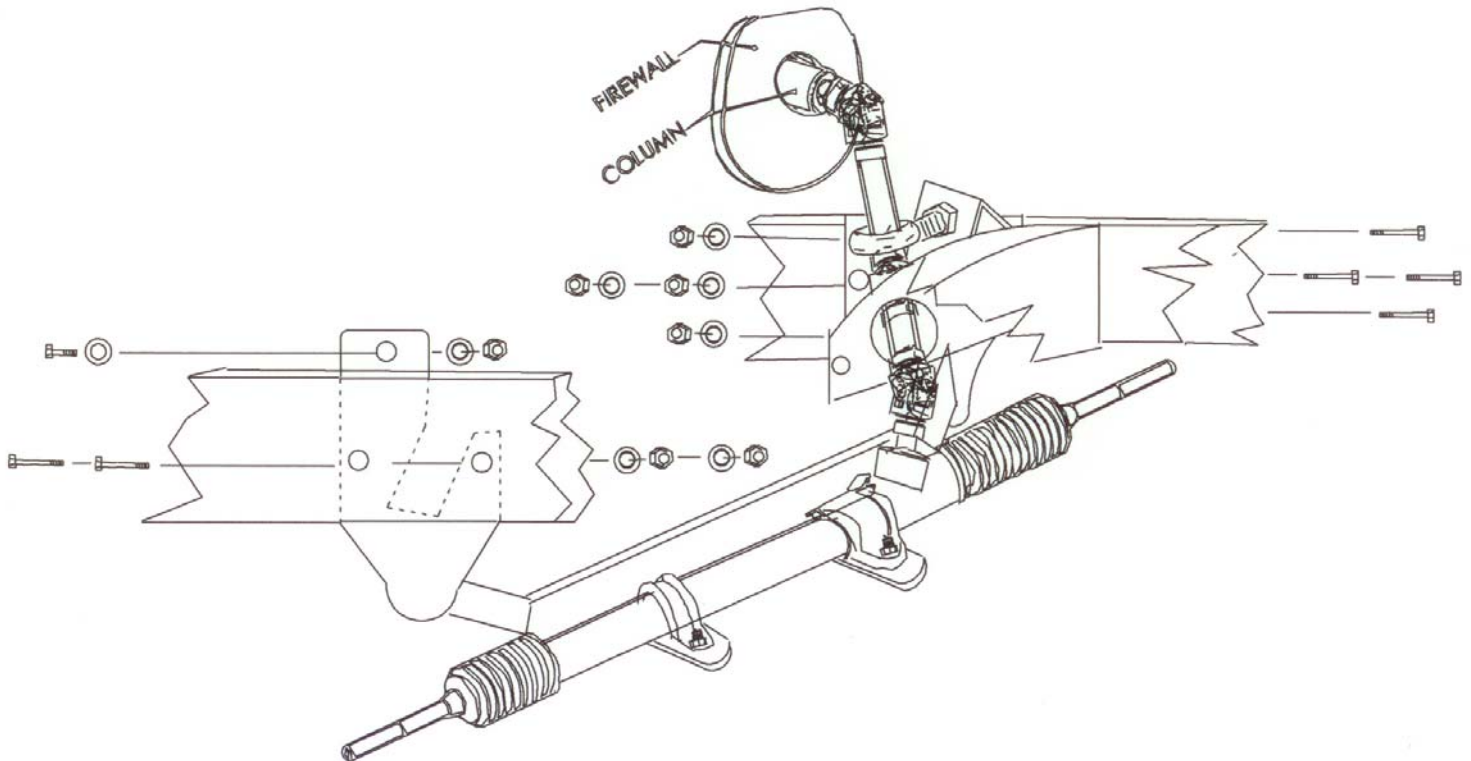

- 1) Begin by centering the rack. Turn the rack all the way to the left. Next turn it all the way to the right counting the number of turns. Then go back to the left half the number of turns.
- 2) Install the passenger side rack mounting clamp onto rack tube.
- 3) Place rack onto cradle mounting feet
- 4) Using the 1 1/2"x 3/8 bolts on the driver's side and 1"x 3/8 bolts on the passenger side mount the rack to the cradle.
- 5) Install the rack and pinion mounting cradle by placing it in between the frame rails and lining up the mounting holes. On the driver's side use the original steering box mounting holes and on the passenger side the idler arm mounting holes.
- 6) Slide the new carriage bolts through the holes and tighten to 45-50 ft lbs.
- 7) Install the outer tie rod ends and jam nuts onto the outer tie rod end assembly and install them into the inner tie rod ends. Adjust the outer ends to the dimension that you checked on the index page.
- 8) Install the outer tie rod ends into the spindle arms.

## Universal Joint System

- 1) Remove the template on the last page.
- 2) Cut out template along the solid line and cut out hole for the motor mount bolt.
- 3) Place cut out template on the engine support bracket aligning the motor mount bolt hole on the motor mount bolt. Template should be facing the firewall.
- 4) Center punch the "X" in the large hole on the template and then cut out the hole using the hole saw in the kit.
- 5) Install support-bearing mount onto a cradle mounting bolt. Note: The angle of this mount is set for most applications. Some adjustment may be necessary for the correct angle and u-joint alignment.

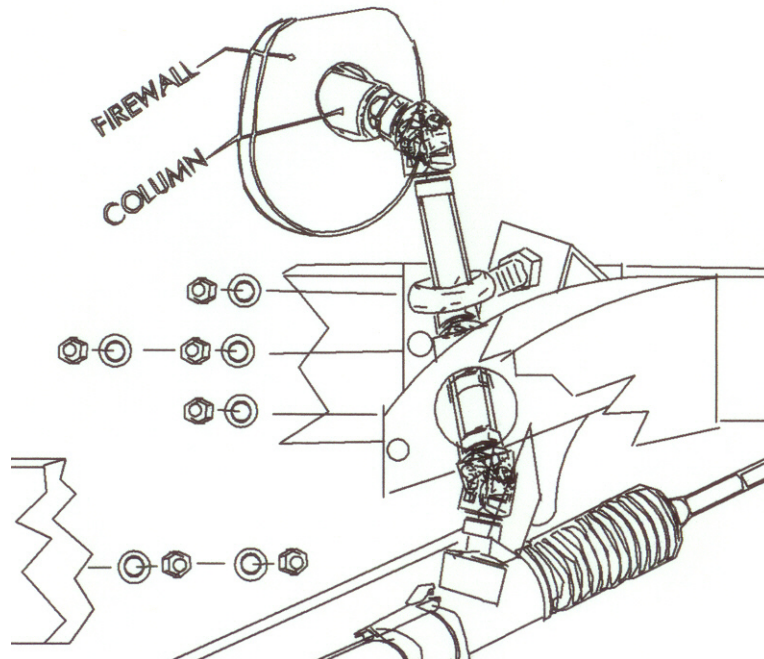

- 6) We recommend the use of  $\frac{3}{4}$ " dowel rod to mock up the steering shaft to obtain the correct length before you cut the steel DD shaft.
- 7) Install your shaft kit and snug each set screw so that it will leave a mark in the shafts.

## Universal Joint System Con't

- 8) Remove shaft and dimple each setscrew mark using a ¼" drill bit.  
(As shown below.)



- 9) Re-install the shafts using **high strength (red) thread locker** on the set screw threads. Tighten each setscrew to 25 ft.-lbs. tighten all lock nuts securely. We recommend that you inspect setscrews periodically for tightness.

## Torque Specs

Cradle to Frame Mounting Bolts	45-50 ft lbs
Outer Tie Rod Ends to Spindle	30-40 ft lbs
Universal Joint Set Screws	25 ft-lbs

## Template

