



A Holley Performance Brand

JOHN LINGENFELTER SIGNATURE LS1 INTAKE MANIFOLD

A handwritten signature in black ink that reads "John Lingenfelter". The signature is written in a cursive, flowing style with a large initial 'J'.

P/N 300-111 & 300-111P

NOTE: These instructions must be read and fully understood before beginning installation. If this manual is not fully understood, installation should not be attempted.

INTRODUCTION:

Congratulations on your purchase of the LS1 Intake Manifold! This manual contains all the information needed to install this manifold. Please read all the **WARNINGS, NOTICES, NOTES, and TIPS.** They contain valuable information that can save you time and money. It is our intent to provide the best possible products for our customer; products that perform properly and satisfy your expectations. Should you need information or parts assistance, please do not return the unit to the store without first contacting technical service at 1-270-781-9741 or toll-free (1-866-GOHOLLEY), Monday through Friday, 7 a.m. to 5 p.m. Central Time. By using this number, you may obtain any information and/or parts assistance that you may require. Please have the part number on hand of the product you purchased when you call technical service.

IMPORTANT INSTALLATION NOTES:

This instruction manual will take the installer through a step by step process to install the **LS1** intake manifold with the engine in the vehicle. Before beginning the installation of the **LS1** intake manifold, several things must be considered:

1. Prior to installation, be sure the vehicle is in good running and mechanical condition. Retrieve all trouble codes from the vehicle's computer, following the manufacturer's procedure. All computer codes must be corrected **BEFORE** installation of the **LS1** intake manifold. Failure to do so may result in driveability problems not associated with the **LS1** intake manifold installation, and in the event of problems, will make diagnosis more difficult.
2. Depending on your experience with manifold installation, the vehicle will be out of service for a day or so. Considerations should be taken accordingly.
3. If the removal and installation of the **LS1** intake manifold components requires removal of either the condenser or air compressor, the air conditioning system must first be evacuated. Take the vehicle to a certified air conditioning technician to recover and evacuate the air conditioning system. Releasing freon gas into the atmosphere is illegal.

DANGER! THIS TYPE OF WORK MUST BE PERFORMED IN A WELL-VENTILATED AREA. DO NOT SMOKE OR HAVE AN OPEN FLAME NEAR GASOLINE VAPORS OR AN EXPLOSION MAY RESULT CAUSING SERIOUS PERSONAL INJURY, PROPERTY DAMAGE, AND/OR DEATH.

DANGER! ALWAYS WEAR SAFETY GLASSES WHEN WORKING ON A VEHICLE. FAILURE TO WEAR EYE PROTECTION MAY RESULT IN SERIOUS EYE INJURY.

WARNING! FOR A SAFE AND RELIABLE INSTALLATION OF THE LS1 INTAKE MANIFOLD KIT, A THOROUGH KNOWLEDGE OF THE VEHICLE'S MECHANICAL AND ELECTRICAL SYSTEMS IS NECESSARY. OTHERWISE, ONLY A PROFESSIONAL MECHANIC SHOULD DO THE INSTALLATION. AN IMPROPERLY INSTALLED MANIFOLD CAN CAUSE POOR PERFORMANCE, PERSONAL INJURY, AND/OR PROPERTY DAMAGE.

PARTS IDENTIFICATION:



ACCESS PLATE GASKET (1)



ACCESS PLATE (1)



INTAKE GASKETS (2)



THROTTLE BODY GASKET (1)



WEIAND INTAKE MANIFOLD (Polished version shown) (1)



BARB FITTINGS (4) & 10-32 x 1/4" SCREWS (10)



M6 x 1 x 90 SHCS & WASHER (10 each)



PURGE CANISTER HOSE (1)



#8 x 32 x 1 FLATHEAD SCREW & #8 WASHER (1 each)

ADDITIONAL PARTS REQUIRED:

- Anti-seize Compound
- Permatex® Ultrablue Sealer
- Antifreeze
- LS-6 Coolant Lines or Modified Stock Coolant Lines

TOOLS REQUIRED:

- 3/8" Ratchet and extensions
- 3/8" Metric Socket Set
- 3/8" Torx / Allen head sockets
- Torque Wrench
- Flathead screw driver

REMOVAL OF STOCK INTAKE MANIFOLD:

1. Disconnect the battery.
2. Disconnect the wiring harness from the Mass Airflow Sensor (M.A.S.). Disconnect the air temperature sensor from the intake tube.
3. Remove the air cleaner housing. Disconnect the cold air intake tube to the throttle body.
4. Disconnect the wiring harness from Throttle Position Sensor (T.P.S.) and Idle Air Control (I.A.C.) on throttle body.
5. Disconnect the cruise and throttle cable from the throttle body.
6. Disconnect the Exhaust Gas Return (E.G.R.) tube from the intake manifold.
7. Disconnect the coolant lines from the underside of the throttle body.
8. Remove the throttle body from the intake.
9. Remove the throttle cable bracket from the intake manifold and retain for later use.

10. Disconnect the wiring harness from the eight (8) fuel injectors and vacuum switch.
11. Disconnect the vacuum lines from the brake booster and the canister purge solenoid.
12. Disconnect the fuel line supply.

DANGER! THIS TYPE OF WORK MUST BE PERFORMED IN A WELL-VENTILATED AREA. DO NOT SMOKE OR HAVE AN OPEN FLAME NEAR GASOLINE VAPORS OR AN EXPLOSION MAY RESULT CAUSING SERIOUS PERSONAL INJURY, PROPERTY DAMAGE, AND/OR DEATH.

DANGER! DO NOT SMOKE OR HAVE AN OPEN FLAME PRESENT NEAR GASOLINE VAPORS OR AN EXPLOSION MAY RESULT CAUSING SERIOUS PERSONAL INJURY, DEATH, AND/OR PERSONAL PROPERTY DAMAGE.

13. Remove the fuel rail and injectors from the engine compartment.
14. Remove the ten (10) manifold-to-cylinder head mounting bolts.
15. Disconnect the wiring harness from the Manifold Absolute Pressure M.A.P. sensor (located on the rear of the manifold).
16. Remove the intake manifold from the engine.
17. Remove the M.A.P. sensor from the manifold and save for later use.

INSTALLATION OF WEIAND ALUMINUM INTAKE MANIFOLD:

1. LS6 engines do not need modification to the valley coolant tubes. 2000 and earlier LS1 engines do need modification. If you want to use the LS6 parts on your LS1 engine, the GM part numbers are #12578838 for the front crossover and #12563325 for the rear plugs. The rear plugs are called the LS6 head water cover and you will need a quantity of 2. If you want to use your stock coolant tubes, you can cut, flatten, fold, and braze/solder the coolant lines, as shown in Figure 1.

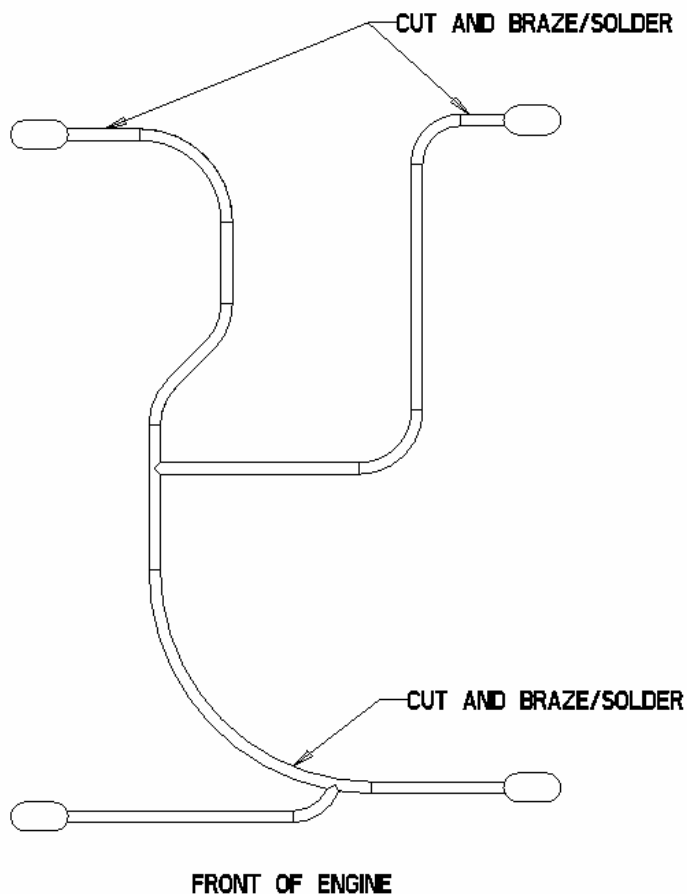

Figure 1

2. If you need to modify or replace the valley coolant lines, drain the coolant and remove the coolant lines from the valley.

3. Install the new or modified coolant lines, if necessary.
4. With the supplied screws, install the access plate with the gasket to the underside of the manifold.

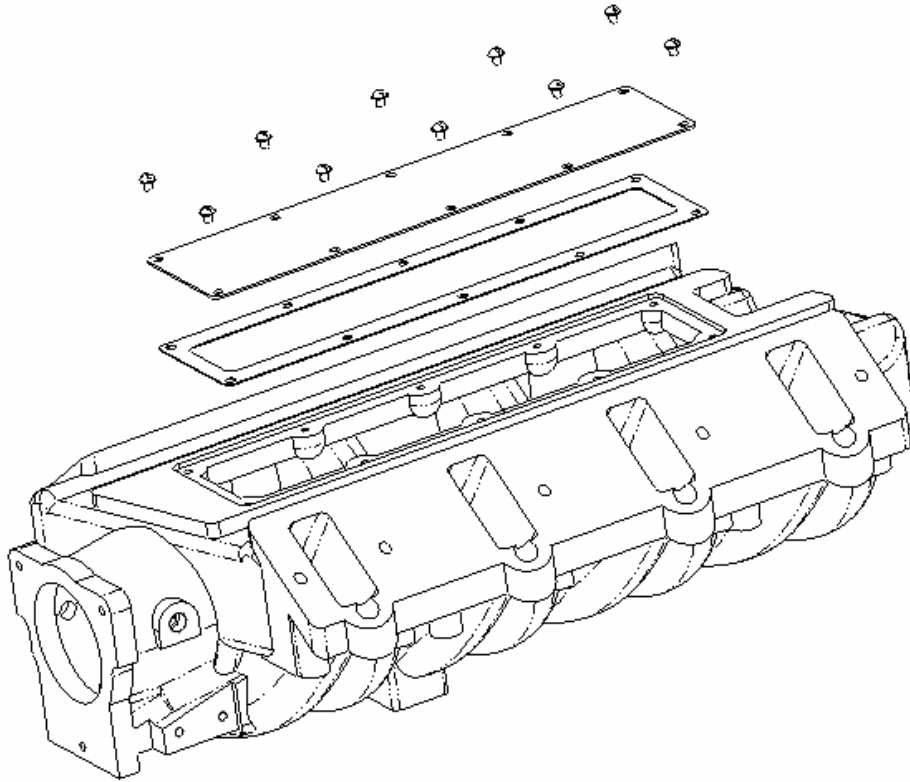

Figure 2

5. Install the 5/16" barb fittings to each side of the manifold behind the throttle body-mounting surface.
6. Install the 1/2" barb fitting and the 1/4" barb fitting in the rear of the manifold.
7. Attach the M.A.P. sensor from the stock manifold to the rear of the Weiand manifold.

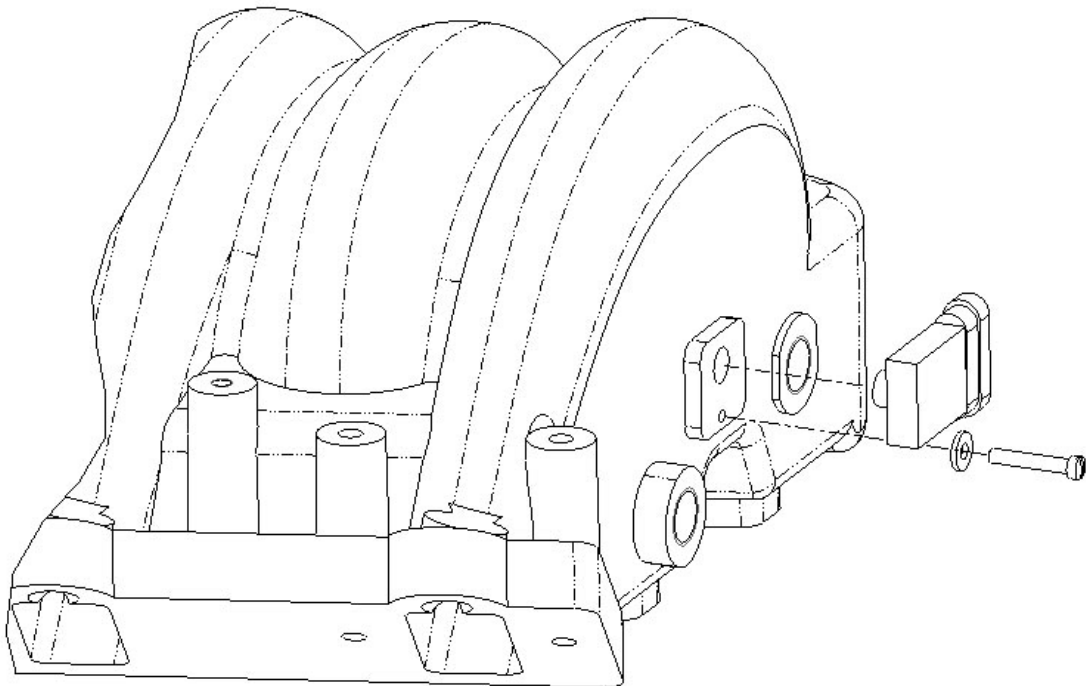

Figure 3

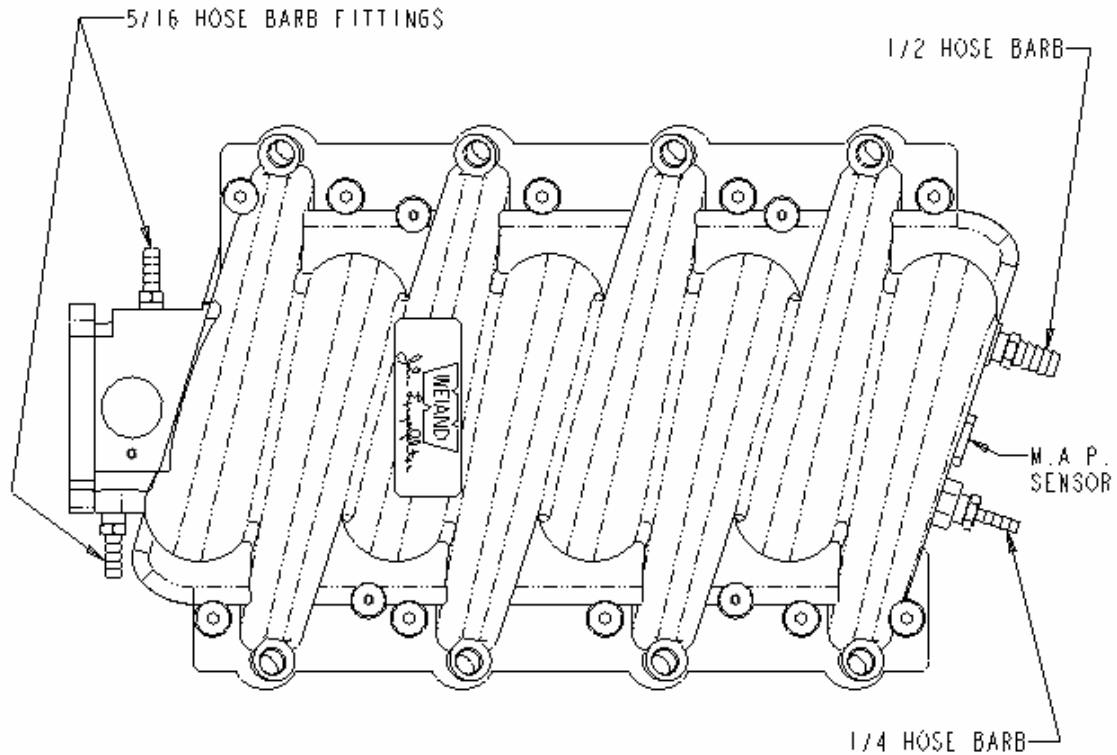

Figure 4

8. Glue the intake gaskets to the cylinder heads, using Permatex® Ultrablue Sealer.
9. Lay the manifold in position on the engine. Connect the vacuum lines to the brake booster and vacuum switch at the rear of the manifold.
10. Carefully, slide the manifold back into position, making sure that the gaskets don't move. Using anti-seize compound, bolt down to 16 ft./lbs. using the supplied M6 x 1 – 90 SHCS and washers. Use the torque sequence shown in Figure 5.

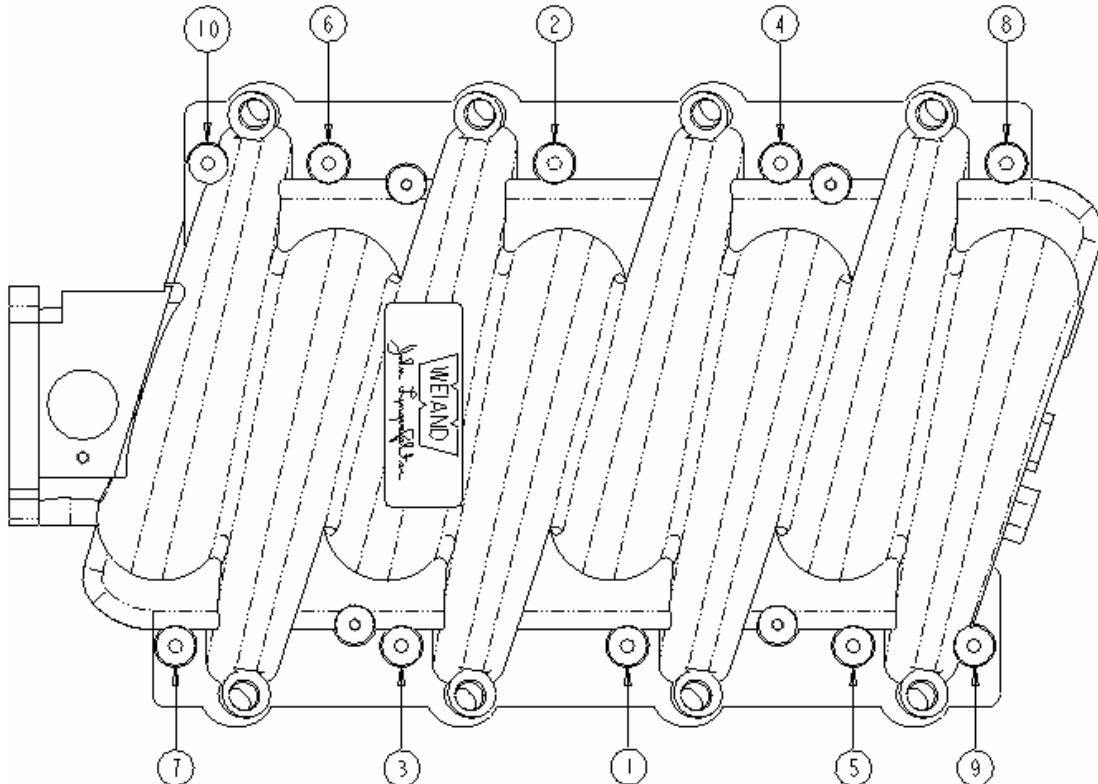

Figure 5

11. Lube the injectors with a light oil. Reinstall the injectors and fuel rail onto the new manifold.
12. Connect the fuel supply to the rail.
13. Reconnect the wiring harness to the injectors and canister purge.
14. Connect the vacuum line to the canister purge from the manifold.

NOTE: Stock hose connector ends will not work with the new manifold. Use the supplied hose to connect the purge canister to the manifold.

15. Install the E.G.R. tube into the manifold and bolt down.
16. Use the supplied throttle body gasket, and remount the throttle body.
17. Reconnect the harness to the T.P.S. and I.A.C.
18. Reconnect the coolant lines to the underside of the throttle body.
19. Reconnect the vacuum line from the throttle body to the Positive Crankcase Ventilation (P.C.V.) system.
20. Attach the stock throttle cable bracket to the Weiand intake manifold.
21. Reconnect the throttle cable and cruise control cable to the bracket and throttle body.
22. Reinstall the cold air intake tube. Reconnect the wiring harness to the M.A.S. and air temperature sensor.
23. Refill the coolant.
24. Reconnect the battery and start the engine.
25. Check for vacuum and coolant leaks.
26. ENJOY!



**Holley Performance Products
P.O. Box 10360**

Bowling Green, KY 42102-7360

Tech Service: 1-270-781-9741

Toll-Free: 1-866-GOHOLLEY

Fax: 1-270-781-9772

**For online help, please refer to the Tech
Service section of our website:**

www.holley.com