

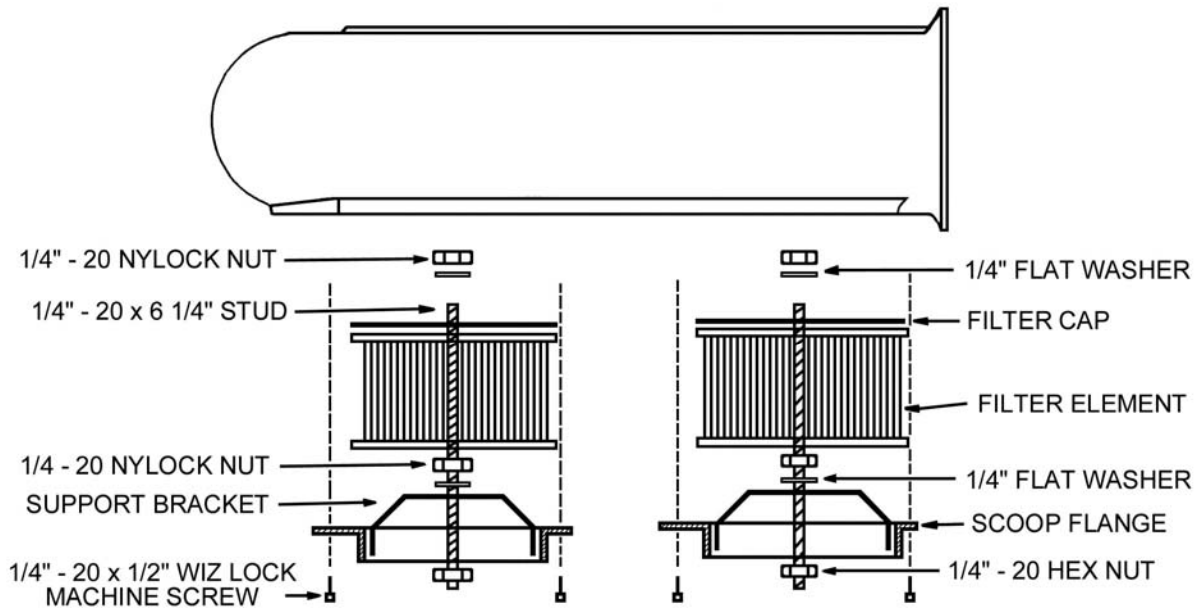

# HILBORN STYLE AIR SCOOP

P/N 7220 & 7221



## #7220 -- SINGLE CARBURETOR APPLICATION #7221 -- DOUBLE CARBURETOR APPLICATION

**CAUTION! DO NOT OVERTIGHTEN NUTS OR BOLTS!**

1. Remove the existing air cleaner parts from the carburetor(s).
2. Install the stud(s) and hex nut(s) to the carburetor(s). Cut the stud(s), if necessary to clear the scoop.
3. Place the scoop flange(s) on the carburetor(s).
4. Place the support bracket(s) on the scoop flange(s).
5. Assemble the washer(s) and nylock nut(s) to the stud(s).
6. Place the filter element(s) and filter cap(s) on the flange(s).
7. Assemble the washer(s) and nylock nut(s) to the studs.
8. Place the scoop on top of the scoop flange(s). Install the 1/4" – 20 x Wiz lock machine screws.
9. Check the hood clearance before closing the hood.

**NOTE: Check the hood modifications with the local authorities before operating the vehicle for street use.**

**NOTE: Not legal for street use on pollution-controlled vehicles.**

Holley Performance Products  
P.O. Box 10360  
Bowling Green, KY 42102-7360

Technical Service: 270-781-9741 Fax: 270-781-9772 For online help, please refer to the Tech Service section of our website: [www.holley.com](http://www.holley.com)

W546  
Date: 6-12-01