

ASSEMBLY INSTRUCTIONS
FOR
DYNAPRO BIG BRAKE FRONT HAT KIT - DRAG RACE
WITH 11.75" DIAMETER VENTED ROTOR

1998 - 2002 CAMARO / FIREBIRD

PART NUMBER GROUP

140-10787

**DISC BRAKES SHOULD ONLY BE INSTALLED BY SOMEONE
EXPERIENCED AND COMPETENT IN THE INSTALLATION
AND MAINTENANCE OF DISC BRAKES**

READ ALL WARNINGS

WARNING

IT IS THE RESPONSIBILITY OF THE PERSON INSTALLING ANY BRAKE COMPONENT OR KIT TO DETERMINE THE SUITABILITY OF THE COMPONENT OR KIT FOR THAT PARTICULAR APPLICATION. IF YOU ARE NOT SURE HOW TO SAFELY USE THIS BRAKE COMPONENT OR KIT, YOU SHOULD NOT INSTALL OR USE IT. DO NOT ASSUME ANYTHING. IMPROPERLY INSTALLED OR MAINTAINED BRAKES ARE DANGEROUS. IF YOU ARE NOT SURE, GET HELP OR RETURN THE PRODUCT. YOU MAY OBTAIN ADDITIONAL INFORMATION AND TECHNICAL SUPPORT BY CALLING WILWOOD AT (805) 388-1188, OR VISIT OUR WEB SITE AT WWW.WILWOOD.COM. USE OF WILWOOD TECHNICAL SUPPORT DOES NOT GUARANTEE PROPER INSTALLATION. YOU, OR THE PERSON WHO DOES THE INSTALLATION MUST KNOW HOW TO PROPERLY USE THIS PRODUCT. IT IS NOT POSSIBLE OVER THE PHONE TO UNDERSTAND OR FORESEE ALL THE ISSUES THAT MIGHT ARISE IN YOUR INSTALLATION.

RACING EQUIPMENT AND BRAKES MUST BE MAINTAINED AND SHOULD BE CHECKED REGULARLY FOR FATIGUE, DAMAGE, AND WEAR.



WARNING

DO NOT OPERATE ANY VEHICLE ON UNTESTED BRAKES!
SEE MINIMUM TEST PROCEDURE WITHIN

ALWAYS UTILIZE SAFETY RESTRAINT SYSTEMS AND ALL OTHER AVAILABLE SAFETY EQUIPMENT WHILE OPERATING THE VEHICLE.

IMPORTANT • READ THE DISCLAIMER OF WARRANTY INCLUDED IN THE KIT.

NOTE: Some cleaners may stain or remove the finish on brake system components. Test the cleaner on a hidden portion of the component before general use.

Important Notice - Read This First

Before any tear-down or disassembly begins, review the following information:

- Review the wheel clearance diagram (figure 2, page 3) to verify that there is adequate clearance with the wheels you will be using with the installation.
- Front brake kits do not include flex lines. OEM brake lines will not adapt to Wilwood calipers. Check the assembly instructions, or associated components section for brake line recommendations before assembly. In addition, Wilwood offers an extensive listing of brake lines and fittings on our web site: www.wilwood.com.
- Due to OEM production differences and other variations from vehicle to vehicle, the fastener hardware and other components in this kit may not be suitable for a specific application or vehicle.
- It is the responsibility of the purchaser and installer of this kit to verify suitability / fitment of all components and ensure all fasteners and hardware achieve complete and proper engagement. Improper or inadequate engagement can lead to component failure.

Exploded Assembly Diagram

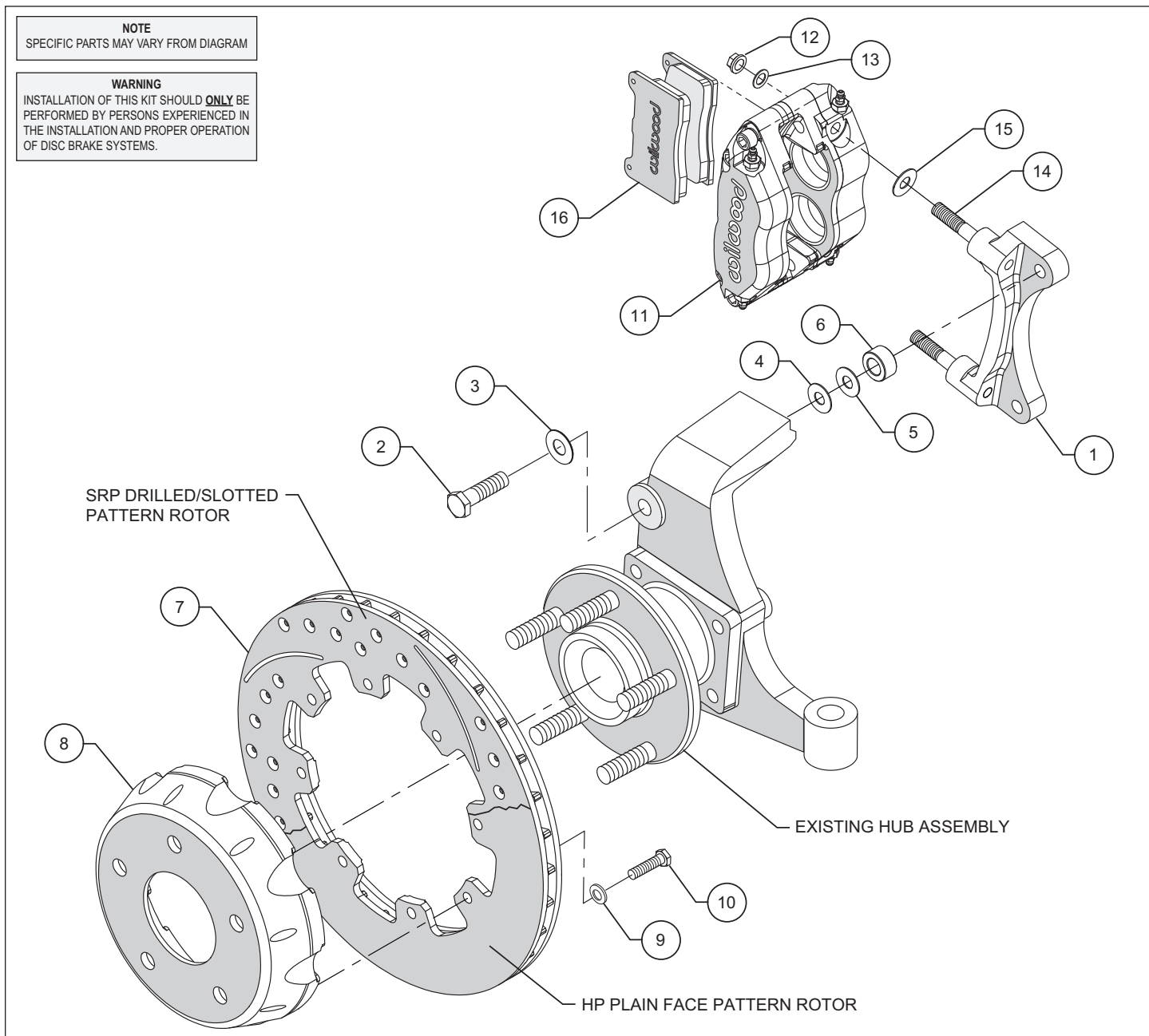

Parts List

<u>ITEM NO.</u>	<u>PART NO.</u>	<u>DESCRIPTION</u>	<u>QTY</u>
1	250-10783	Bracket, Caliper Mounting	2
2	230-10772	Bolt, M12-1.75 x 60mm Long, HXHD	4
3	240-0476	Washer, .477 I.D. x .922 O.D. x .063 Thick	4
4	240-6320	Washer, .483 I.D. x 1.031 O.D. x .033 Thick	12
5	240-5878	Washer, .503 I.D. x 1.051 O.D. x .015 Thick	4
6	300-10788	Spacer, .457 Long	4
7	160-5841	Rotor, .81" Thick x 11.75" Dia, 8 x 7.00" Bolt Circle	2
7A	160-7101/02-BK	Rotor, SRP Drilled and Slotted	2
8	170-10782	Hat, 5 x 4.50, 1.59 Offset, 8 x 7.00" Bolt Circle	2
9	240-0138	Washer, .312 I.D. x .583 O.D., Lock	16
10	230-3822	Bolt, 5/16 x 18 x 1.00 Long, HXHD	16
11	120-10000	Caliper, DynaPro Radial	2
12	230-9183	Nut, 3/8-24 Self-Locking Hex Head	4
13	240-2510	Washer, .391 I.D. x .625 O.D. x .057 Thick	4
14	230-9078	Stud, 3/8-16 x 3/8-24 x 2.50 long (pre installed in bracket)	4
15	240-1159	Washer, .375 I.D. x .875 O.D. x .035 Thick	16
16	150-9136K	Pad, BP-10 Compound, Axle Set	1

NOTES: Part Number 230-0526 Rotor Bolt Kit, includes part numbers 230-3822 and 240-0138

Part Number 230-10803 Bolt Kit, Bracket / Spindle, includes P/N 230-10772, 240-0476, 240-5878 and 240-6320

Part Number 250-10784 Bracket Kit, Caliper, includes part numbers 230-9078, 230-9183, 240-1159, 240-2510 & 250-10783

Item 7A is an optional item and is included in the (D) drilled kits. Add "-D" to end of part number when ordering

Wilwood offers an optional Braided Stainless Steel Hose Kit. Order part number 220-6746 (not included in kit)

General Information and Disassembly Instructions

- Installation of this kit should only be performed by individuals experienced in the installation and proper operation of disc brake systems. Prior to any attempt to install this kit, please check the following to ensure a trouble free installation.
- Inspect the contents of this kit against the parts list to ensure that all components and hardware are included.
- Verify the year and model of your spindle. This kit is designed for direct bolt-on installation to 1998 through 2002 model year production spindles that were originally equipped with twin piston calipers. This kit will not fit 1993 through 1997 production year spindles originally equipped with single piston floating mount calipers. The correct spindles are identified by casting numbers 18023021 and 18023022. 1993 through 1997 model year vehicles may be updated with the later model spindle to accommodate installation of this kit.
- Verify your wheel clearance using figure 2.
- Verify that the factory hub and stud pattern matches the stud hole pattern in the hats supplied with this kit. Hubs that have been modified with different size studs or lug patterns may require modifications to the hat that must be performed by a qualified machinist.

Disassembly

- Disassemble the original equipment front brakes:
Raise the front wheels off the ground and support the front suspension according to the vehicle manufacturer's instructions.
- Remove the wheel. Remove the two bolts from the backside of the spindle that hold the stock caliper mounting bracket and lift off the bracket and stock caliper as one unit. If space is a problem, you may have to unbolt the stock caliper from the caliper bracket before removal. Remove dust face plate.

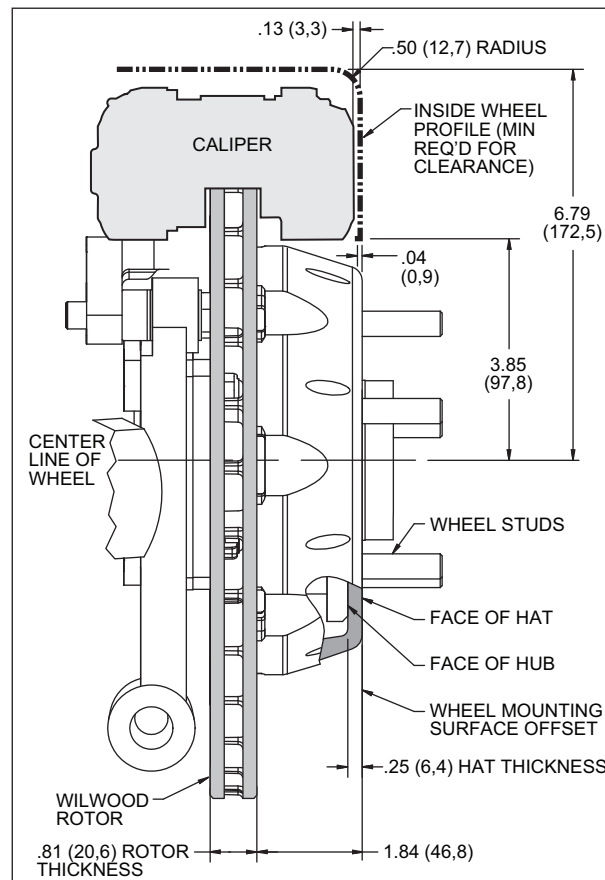

Figure 2. Wheel Clearance Diagram

- Clean and de-grease the spindles. Remove all nicks or burrs on the hub face and wheel stud threads.

Assembly Instructions

Assembly Instructions (numbers in parenthesis refer to the part list/diagram on the preceding pages): **CAUTION:** All mounting bolts must fully engage insert nuts. Be sure to check that all bolts are either flush or protruding through flanged side of insert nut after shimming.

•The caliper mount bracket assembly (1) should be installed first with clean, dry threads on the mounting bolts. Install the bracket on the inboard side of the spindle by sliding bolt (2) through flat washer (3), and spindle ear from the outboard side of the spindle. Place two shim washers (4) and the spacer (6) between the bracket (1) and the spindle (see figure 1). The bracket must tighten squarely against the inboard side of the caliper mount bosses on the spindle body. Inspect for interference from casting irregularities, machining ridges, burrs, etc. Later, after the caliper, pad, and rotor alignment has been checked, and any necessary shims have been put in place, the mount bolts should be coated with red *Loctite*® 271 and torqued to 65 ft-lbs.

•With the larger I.D. side of the rotor (7) facing away from the hat (8), bolt the rotor (7) to the hat (8) through the backside of the rotor using washers (9) and bolts (10) provided in the configuration pictured in figure 1. Be sure all bolts thread in smoothly and are snug. Then, torque all bolts in an alternating sequence to 180 **in-lbs**. Safety wire bolts (10) using standard 0.032 inch diameter stainless steel safety wire as shown in Figure 4. Please refer to Wilwood's data sheet DS-386 (available at www.wilwood.com/pdf/ds386.pdf) for complete safety wire installation instructions.

•Install the hat and rotor assembly onto the hub. Check to be sure the hat seats squarely against the hub. The hub must be free from any rust, debris, casting burrs, machining irregularities, etc. Use several lug nuts to hold the rotor and hat firmly against the hub during the next phases of the installation and clearance checking procedures.

•Lubricate caliper mounting studs (14) and nuts (12) with lightweight oil. Install two shims (15) over each stud (14) on the radial mount bracket. Slide the caliper (11) in place over the studs and rotor and install the washer (13) and lock nut (12) to hold the caliper in place. Snug the lock nuts (12) and check that the rotor (7) is centered in the caliper (11). Add or subtract shims (4 and/or 5) as necessary between the mount bracket and the spindle to center the caliper.

•Remove the caliper quick-clip pad retainer from the caliper. Slide the brake pads (16) into place. They should install easily without interference. Check that the outside radius of the brake pad is flush with the outside diameter of the rotor face. Add or subtract shims (15) between the caliper and mount bracket to gain the proper alignment. Reinstall the quick-clip pad retainer.

•Remove the lug nuts that were holding the hat in place. Install the wheel and torque the lug nuts to specification. Check to see that the wheel rotates freely without interference.

•Once all clearances have been checked, remove the wheel, caliper, hat, and rotor from the spindle and hub. Secure the caliper mounting bracket (1) to the spindle using red *Loctite*® 271. Torque the bolts to 65 ft-lbs. Reinstall the hat and rotor assembly and again use several lug nuts to hold it in place. Reinstall the caliper, torque the caliper nuts (12) to 30-35 ft-lbs.

•Install braided flexline kit part number 220-6746 (not included). The 10mm x 1 to -3 (P/N 220-6890) male fitting installs to the stock bulkhead. Then install the straight 1/8-27 to -3 NPT (P/N 220-6956) fitting into the caliper (11). Finally, install the flex line (P/N 220-6746) to the two previously installed fitting. **Carefully route lines to prevent contact with moving suspension, brake or wheel components.** Wilwood hose kits are designed for use in many different vehicle applications and it is the installer's responsibility to properly route and ensure adequate clearance and retention for brake hose components.

•Specified brake hose kits may not work with all Years, Makes and Models of vehicle that this brake kit is applicable to, due to possible OEM manufacturing changes during a production vehicle's life. It is the installer's responsibility to ensure that all fittings and hoses are the correct size and length, to ensure proper sealing and that they will not be subject to crimping, strain and abrasion from vibration or interference with suspension components, brake rotor or wheel.

•In absence of specific instructions for brake line routing, the installer must use his best professional judgment on correct routing and retention of lines to ensure safe operation. Test vehicle brake system per the 'minimum test' procedure stated within this document before driving. After road testing, inspect for leaks and interference. Initially after install and testing, perform frequent checks of the vehicle brake system and lines before driving, to confirm that there is no undue wear or interference not apparent from the initial test. Afterwards, perform periodic inspections for function, leaks and wear in a interval relative to the usage of vehicle.

•Repeat the procedure for the other wheel.

•Bleed the brake system. Reference the general information and recommendations below for proper bleeding instructions.

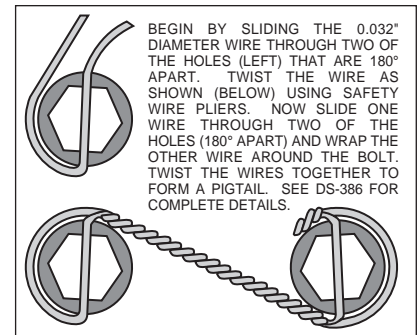

Figure 3. Safety Wire Diagram

Additional Information and Recommendations

- Please read the following concerning balancing the brake bias on 4 wheel disc vehicles.

This Camaro kit can be operated using the stock OEM master cylinder. However, as with most suspension and tire modifications (from OEM specifications), changing the brakes may alter the front to rear brake bias. Rear brakes should not lock up before the front. Brake system evaluation and tests should be performed by persons experienced in the installation and proper operation of brake systems. Evaluation and tests should be performed under controlled conditions. Start by making several stops from low speeds then gradually work up to higher speeds. Always utilize safety restraint systems while operating vehicle.

- For optimum performance, fill and bleed the new system with Wilwood Hi-Temp^o 570 grade fluid or EXP 600 Plus. For severe braking or sustained high heat operation, use Wilwood EXP 600 Plus Racing Brake Fluid. Used fluid must be completely flushed from the system to prevent contamination. **NOTE:** Silicone DOT 5 brake fluid is **NOT** recommended.

- To properly bleed the brake system, begin with the caliper farthest from the master cylinder. Bleed the outboard bleed screw first, then the inboard. Repeat the procedure until all calipers in the system are bled, ending with the caliper closest to the master cylinder. **NOTE:** When using a new master cylinder, it is important to bench bleed the master cylinder first.

- Test the brake pedal. It should be firm, not spongy and stop at least 1 inch from the floor under heavy load.
If the brake pedal is spongy, bleed the system again.

If the brake pedal is initially firm, but then sinks to the floor, check the system for fluid leaks. Correct the leaks (if applicable) and then bleed the system again.

If the brake pedal goes to the floor and continued bleeding of the system does not correct the problem, a master cylinder with increased capacity (larger bore diameter) may be required. Wilwood offers various lightweight master cylinders with large fluid displacement capacities.

- NOTE:** With the installation of after market disc brakes, the wheel track may change depending on the application. Check your wheel offset before final assembly.

- If after following the instructions, you still have difficulty in assembling or bleeding your Wilwood disc brakes, consult your local chassis builder, or retailer where the kit was purchased for further assistance.

Brake Testing and Pad Bedding

WARNING • DO NOT DRIVE ON UNTESTED BRAKES BRAKES MUST BE TESTED AFTER INSTALLATION OR MAINTENANCE MINIMUM TEST PROCEDURE

- Make sure pedal is firm: Hold firm pressure on pedal for several minutes, it should remain in position without sinking. If pedal sinks toward floor, check system for fluid leaks. DO NOT drive vehicle if pedal does not stay firm or can be pushed to the floor with normal pressure.
- At very low speed (2-5 mph) apply brakes hard several times while turning steering from full left to full right, repeat several times. Remove the wheels and check that components are not touching, rubbing, or leaking.
- Carefully examine all brake components, brake lines, and fittings for leaks and interference.
- Make sure there is no interference with wheels or suspension components.
- Drive vehicle at low speed (15-20 mph) making moderate and hard stops. Brakes should feel normal and positive. Again check for leaks and interference.
- Always test vehicle in a safe place where there is no danger to (or from) other people or vehicles.
- Always wear seat belts and make use of all safety equipment.

PAD BEDDING PROCEDURE:

• Pump brakes at low speed to assure proper operation. On the race track, or other safe location, make a series of hard stops until some brake fade is experienced. Allow brakes to cool while driving at moderate speed to avoid use of the brakes. This process will properly burnish the brake pads, offering maximum performance.

Associated Components

<u>PART NO.</u>	<u>DESCRIPTION</u>
260-1874	Wilwood Residual Pressure Valve (2 lb for disc brakes)
260-8419	Wilwood Proportioning Valve, Knob Style
260-8420	Wilwood Proportioning Valve, Lever Style
290-6209	Wilwood Racing Brake Fluid (EXP 600 Plus) (16.9 oz)
340-1285	Wilwood Floor Mount Brake Pedal (with balance bar)
340-1287	Wilwood Swing Mount Brake Pedal (with balance bar)
260-3376	Wilwood 7/8 inch Bore Combination Master Cylinder
260-5920	Wilwood 13/16 inch Bore Combination Master Cylinder
260-8555	Wilwood 1 inch Aluminum Tandem Chamber Master Cylinder
260-8556	Wilwood 1-1/8 inch Aluminum Tandem Chamber Master Cylinder
15E-9837K	PolyMatrix 7812 "E" Compound Brake Pads (Medium Temperature)
130-2655	Caliper O-Ring Seal Kit
220-6746	Flexline Stainless Steel Hose Kit
150-9418K	Pad 7812, DynaPro, BP-20 Compound (medium temperature)