



9400 7TH ST. UNIT C-1  
 Rancho Cucamonga, CA 91730  
 (909) 476-7225 TECH SUPPORT  
 (909) 476-1491 FAX  
 www.volantperformance.com

**PART NO. 25743**

MAKE	MODEL	YEAR	LITER
CHEVROLET	ASTRO VAN	96-01	4.3
GMC	SAFARI	96-01	4.3

**ACCESSORIES:**

VOLANT REPLACEMENT FILTER  
 AIR FILTER CLEANER KIT  
 VOLANT PREFILTER

**PART NO.**

VFRV356  
 VFCKB  
 VPF356

**INSTALLATION INSTRUCTIONS PART NO. 25743**

READ INSTRUCTIONS THOROUGHLY BEFORE DISASSEMBLING. DO NOT SKIP ANY STEPS. ANY QUESTIONS ON A VOLANT KIT MAY BE REFERRED TO OUR TECH SUPPORT LINE AT (909) 476-7225 OR VISIT OUR WEBSITE AT WWW.VOLANTPERFORMANCE.COM

**TOOLS NEEDED FOR INSTALL:**

1. FLAT HEAD SCREW DRIVER OR 5/16 NUT DRIVER
2. 10 MM SOCKET AND RATCHET WRENCH

**INSTALLATION:**

1. Turn vehicle to the off position.
2. Loosen the hose clamp on your filter box that connects the mass flow sensor to the box. Pull the sensor out.
3. Remove the filter box from your engine compartment by pulling straight up and away from the rubber grommets that hold the box down.
4. Disconnect and pull the air temperature sensor from your stock air duct.
5. Loosen the hose clamp on the stock rubber air duct that connects to the mass flow sensor. Pull the mass flow sensor out and gently set to the side. Loosen the hose clamp on the other end of the air duct and remove it from the stock bonnet located on your throttle body.
6. Install the Volant 3 1/2" sleeve to the Volant air duct, which has a rubber grommet for the air temperature sensor. Slip the 3 1/2" sleeve on the end furthest from the rubber grommet. Once the sleeve is

on, connect the Volant air duct to the stock bonnet on the throttle body. Use the #056 hose clamps provided by Volant.

7. Place a hose clamp provided by Volant on the other end of the Volant air duct. Insert the mass flow sensor in the Volant air duct with the arrow pointing towards the throttle body. Tighten the hose clamp.
8. Slip the 3/4" sleeve on the smaller end of the Volant air duct elbow. Connect the Volant elbow with sleeve to the mass flow sensor.
9. On the other end of the Volant duct. Position the shield on the filter to clamp both Volant shield and filter together to the Volant duct. Do not completely tighten to allow you to rotate the shield in the right location in the engine compartment to shield the filter from the heat.
10. Insert the stock air temperature sensor in the Volant air duct closest to the throttle body.
11. Connect the Volant bracket to the insert on the Volant elbow using the longer bent end. Connect the other end to the vehicle using the stock bolt located between the power steering fluid and windshield wiper motor.
12. Make sure everything is tightened and properly connected.
13. Place the C.A.R.B. label on or near the Volant system in the engine compartment.

**WARNING: OVER TIGHTENING HARDWARE MAY ALTAR THE INTEGRITY OF THE VOLANT AIR INTAKE SYSTEM.**

**BEFORE ROAD TESTING**

1. Start engine, leaving the transmission in park and securing the parking brake.
2. Make sure to look and listen for any unusual noises or air leaks. Repair problems if needed.
3. Once completed it will be necessary to check periodically for realignment and tightening of all connections.
4. Once all tests are completed, enjoy the performance of your new Volant Air Intake System.

**CARE AND CLEANING**

Check the cotton reusable filter periodically and remove any excessive dirt build-up by tapping the filter on the ground and brushing off the loosened dirt. Clean the filter by using Volant's Filter Recharger Kit. Volant's Filter Recharger Kit is designed to restore original air flow. Re-oil every 10,000 miles without cleaning to improve filtering in sand and dirt. Clean only when dirt is very excessive or 50,000 miles.

**25743 INSTALLATION**

List of component parts (please confirm that you have all parts before starting the installation)

- 1 VOLANT AIR DUCT
- 1 VOLANT ELBOW
- 1 VOLANT SHIELD
- 1 RAM FILTER W/CLAMP
- 2 #048 CLAMPS
- 3 #056 CLAMPS
- 1 3 1/4" X 3" SLEEVE
- 1 3 1/2" X 3" SLEEVE
- 1 1/4"-20 BOLT
- 2 1/4" WASHERS
- 2 1/4" LOCK WASHERS
- 1 AIR DUCT BRACKET
- 1 1/2" RUBBER GROMMET

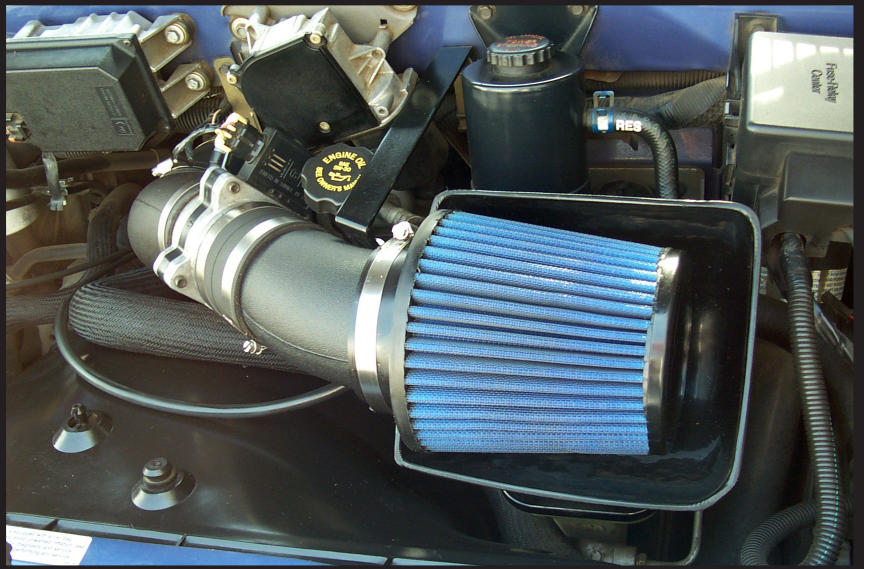

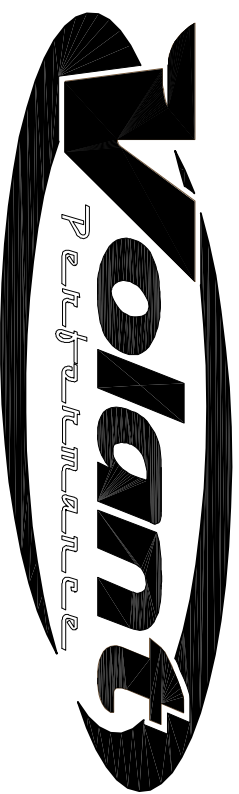

TOP  
VIEW

NOTE: ATTACH THE VOLANT BRACKET TO THE EXISTING BOLT LOCATED BETWEEN THE WINDSHIELD WIPER MOTOR AND THE POWER STEERING FLUID BOX.

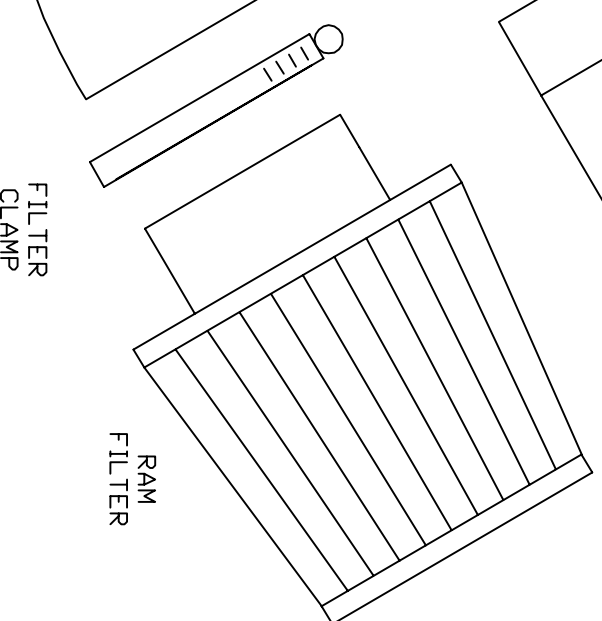
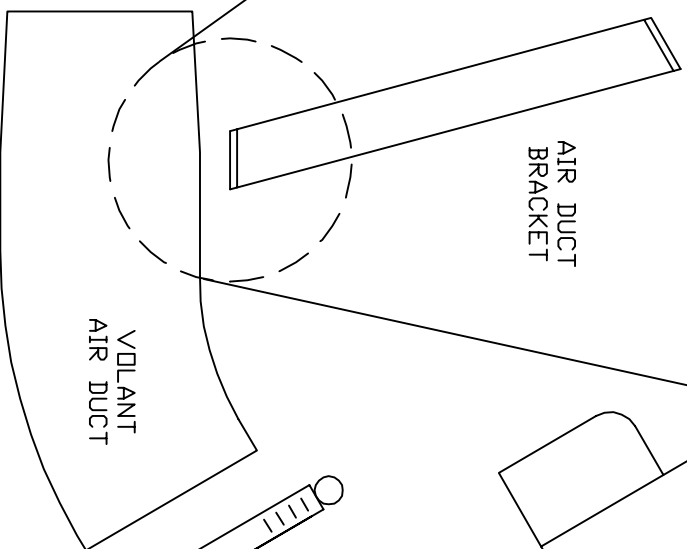
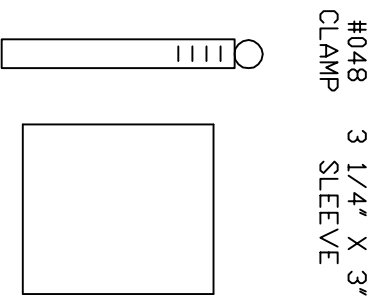
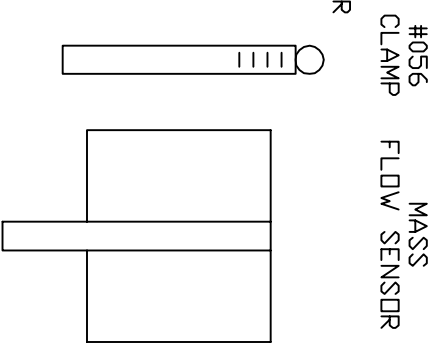
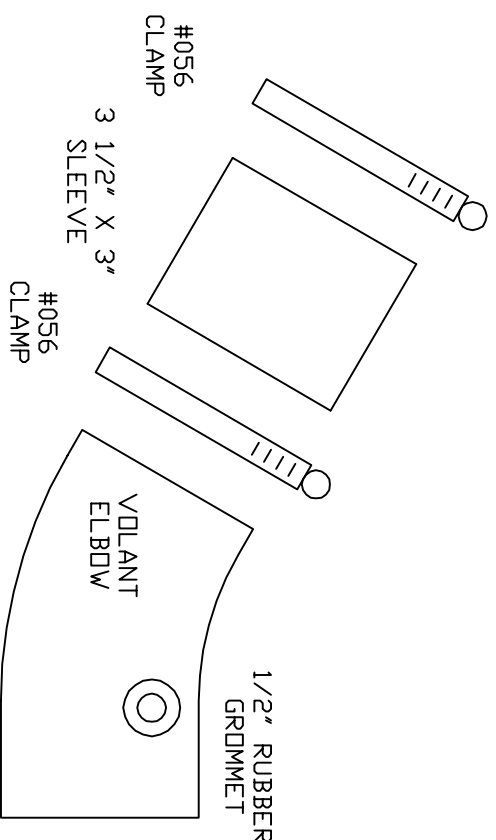
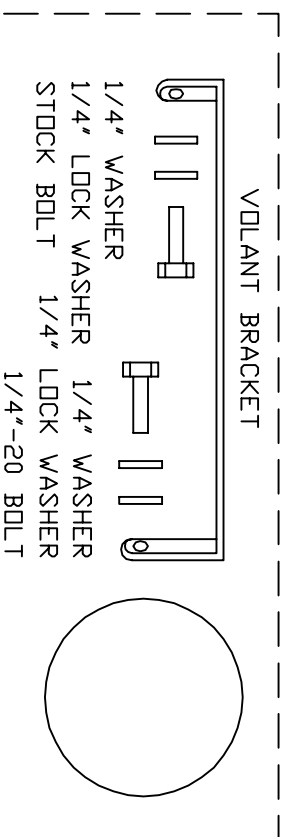

#048  
CLAMP

NOTE: USE THE FILTER CLAMP FOR BOTH THE VOLANT SHIELD AND THE RAM FILTER.

VOLANT AIR INTAKE SYSTEMS  
PART NO.: 25743  
INSTALLATION INSTRUCTIONS  
WWW.VOLANTPERFORMANCE.COM  
TECH SUPPORT: (909) 476-7225

25743 PARTS LIST

1	VOLANT AIR DUCT	1	3 1/2" X 3" SLEEVE
1	VOLANT ELBOW	1	1/4"-20 BOLT
1	VOLANT SHIELD	2	1/4" WASHER
1	RAM FILTER W/CLAMP	2	1/4" LOCK WASHER
2	#048 CLAMPS	1	AIR DUCT BRACKET
3	#056 CLAMPS	1	1/2" RUBBER GROMMET
1	3 1/4" X 3" SLEEVE		