

**STX200 RUNNING BOARDS
2013-14 NISSAN PATHFINDER**

Parts List:

2	Running Boards	4	Front and Rear Locking Plates
1	Driver/Left Front Mounting Bracket	2	Long Center Locking Plates
1	Passenger/Right Front Mounting Bracket	2	10mm Double Bolt Plates
1	Driver/Left Front Long Inner Support Bracket	18	10mm Low Profile Single Bolt Plates
1	Passenger/Right Front Short Inner Support Bracket	18	10mm Plastic Retainers
2	Front "L" Outer Support Brackets	22	10mm x 27mm OD x 3mm Flat Washers
1	Driver/Left Center Mounting Bracket	22	10mm Lock Washers
1	Passenger/Right Center Mounting Bracket	22	10mm Hex Nuts
2	Center Support Brackets	8	8-1.25mm x 30mm Hex Bolts
1	Driver/Left Rear Frame Mounting Bracket	20	8mm x 28mm OD x 3mm Flat Washers
1	Passenger/Right Rear Frame Mounting Bracket	12	8mm Lock Washers
1	Driver/Left Rear Mounting Bracket	12	8mm Hex Nuts
1	Passenger/Right Rear Mounting Bracket	12	6-1.0mm x 20mm T-Bolts
1	Driver/Left Rear "7" Outer Support Bracket	12	6mm x 22mm OD x 2mm Flat Washers
1	Passenger/Right Rear "7" Outer Support Bracket	12	6mm Lock Washers
		12	6mm Hex Nuts

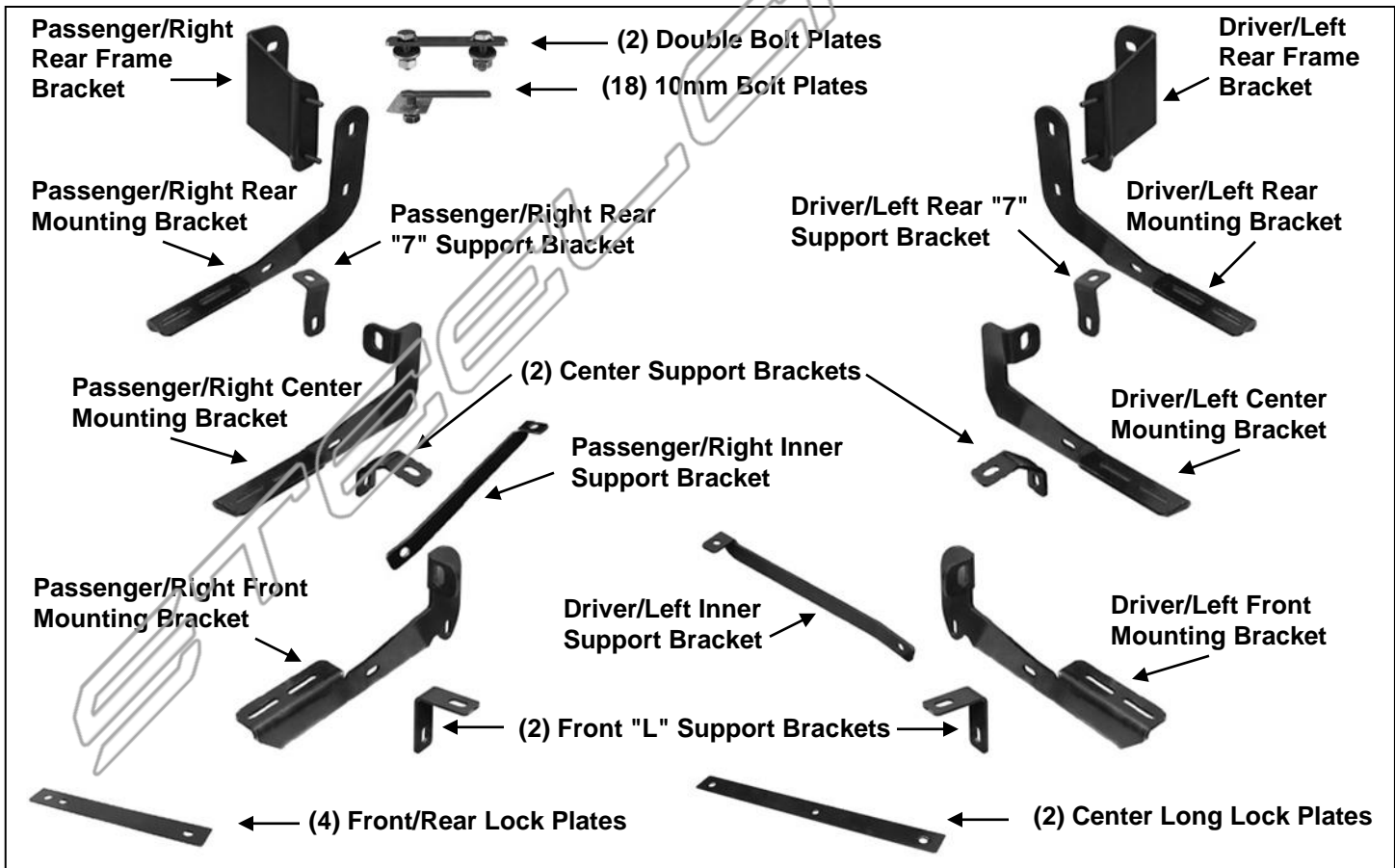

PROCEDURE:

- 1. REMOVE CONTENTS FROM BOX. VERIFY ALL PARTS ARE PRESENT. READ INSTRUCTIONS CAREFULLY.**
- Start installation on the passenger side of the vehicle. Locate and remove the (2) rubber plugs in the bottom of the outer frame channel closest to the front wheel opening, **(Figure 1)**.

**STX200 RUNNING BOARDS
2013-14 NISSAN PATHFINDER**

3. Select (2) 10mm Bolt Plates and (2) 10mm Plastic Retainers, **(Figure 2A)**. Partially thread the Retainers onto the Bolt Plates. **NOTE:** The Plastic Retainer is designed to help hold the Bolt Plate in place during Bracket installation.
4. Insert (1) Bolt Plate into the first-forward hole with the plate pointed toward the rear of the vehicle, **(Figure 2B)**. Thread the Plastic Retainer down tight against the body panel. Repeat to install the next Bolt Plate into the second hole with the Plate pointed toward the front of the vehicle, **(Figures 2B & 3)**. **IMPORTANT:** The Plates on the (2) Bolt Plates must be pointed toward each other, **(Figure 3)**. Repeat this **Step** for all (6) Lock Plate installations.
5. Select (1) Front or Rear Lock Plate, **(Figure 3)**. Slide the Lock Plate over the (2) Bolt Plates with the bent side toward the pinch weld. Attach the Lock Plate to the rear Bolt Plate only with (1) 10mm Flat Washer, (1) 10mm Lock Washer and (1) 10mm Hex Nut, **(Figure 4)**. Tighten the Hex Nut at this time.
6. Locate the round hole in the back of the outer frame channel directly behind the previously installed Bolt Plates, **(Figures 1 & 5)**. Remove the rubber plug. Select (1) 10mm Bolt Plate and (1) 10mm Plastic Retainer, **(Figure 2A)**. Partially thread the Retainer onto the Bolt Plate. Insert the Bolt Plate into the hole and tighten the Retainer as previously described in **Step 4**. Repeat this **Step** for all (6) single Bolt Plate installations.

IMPORTANT: Mounting areas may be covered with undercoating. Scrape excess undercoating from body panel at all mounting locations. Brackets must mount flat against body panels.

7. Select (1) Front "L" Support Bracket, **(Figure 6A)**. Attach the shorter leg on the Support Bracket to the front Bolt Plate with (1) 10mm Flat Washer, (1) 10mm Lock Washer and (1) 10mm Hex Nut, **(Figure 6B)**. Leave hardware loose at this time.
8. Select the passenger side Front Mounting Bracket. Attach the Bracket to the Bolt Plate in the back of the frame channel first with (1) 10mm Flat Washer, (1) 10mm Lock Washer and (1) 10mm Hex Nut, **(Step 6, Figure 7)**. Attach the Mounting Bracket to the back of the previously installed "L" Support Bracket with (1) 8mm x 30mm Hex Bolt, (2) 8mm Flat Washers, (1) 8mm Lock Washer and (1) 8mm Hex Nut, **(Figures 7 & 8)**. Do not tighten hardware at this time.
9. Select (1) 10mm Bolt Plate and (1) 10mm Plastic Retainer, **(Figures 2A & 9)**. Partially thread the Retainer onto the Bolt Plate.
10. Next, locate the factory holes in the bottom of the inner frame channel directly behind the tie down loop where the frame is joined together. Insert the Bolt Plate, (as per **Step 4**), into the correct factory hole:
Passenger side installation: Use the 2nd factory hole back from the loop, **(Figures 11 & 12)**.
Driver side installation: Use the factory hole closest to the tie down loop, **(Figure 13)**.
11. Select the correct Inner Front Support Bracket, **(Figure 10)**. Attach the 90-degree bent end of the Support Bracket to the Bolt Plate in the frame channel with (1) 10mm Flat Washer, (1) 10mm Lock Washer and (1) 10mm Hex Nut, **(Figures 11 & 13)**.
12. Bolt the outer end of the Support Bracket to the front Mounting Bracket with (1) 8mm x 30mm Hex Bolt, (2) 8mm Flat Washers, (1) 8mm Lock Washer and (1) 8mm Hex Nut, **(Figures 12 & 13)**.
13. **Attach the passenger side** Inner Support Bracket to the **back** of the Front Mounting Bracket, **(Figures 11 & 12)**.
Attach the driver side Inner Support Bracket to the **front** of the Front Mounting Bracket, **(Figure 13)**. Do not tighten hardware at this time.
14. Move along the side of the vehicle to the approximate center where the doors meet. Locate and remove the (2) rubber plugs from the bottom of the outer frame channel. Repeat **Steps 3—5** to install (2) Bolt Plates and (1) Long Center Lock Plate to the bottom of the frame channel, **(Figures 14 & 15)**.
15. Next, locate the single hole in the back of the outer frame channel, **(Figure 16B)**. Remove rubber plug if equipped. Select (1) 10mm Bolt Plate and (1) 10mm Plastic Retainer, **(Figures 2A & 9)**. Install the Bolt Plate and Retainer in the back of the frame channel as previously described in **Steps 4 & 6**, **(Figure 16B)**.
16. Select (1) Center Support Bracket, **(Figure 16A)**. Attach the long end of the Support Bracket to the forward Bolt Plate in the frame channel with (1) 10mm Flat Washer, (1) 10mm Lock Washer and (1) 10mm Hex Nut, **(Figures 16B & 18)**. Select the passenger side Center Bracket, **(Figure 17)**. Attach the Bracket to the Bolt Plate in the back of the frame channel, **(Step 15)**, with (1) 10mm Flat Washer, (1) 10mm Lock Washer and (1) 10mm Hex Nut. Bolt the Center Bracket to the Support Bracket with (1)

**STX200 RUNNING BOARDS
2013-14 NISSAN PATHFINDER**

- 8mm x 30mm Hex Bolt, (2) 8mm Flat Washers, (1) 8mm Lock Washer and (1) 8mm Hex Nut, **(Figure 18)**. Do not tighten hardware at this time.
17. Move to the rear mounting location in front of the passenger side rear tire opening. Locate the large oval and round holes in the inner body panel in front of the rear tire, **(Figure 19)**. Select (1) 10mm Double Bolt Plate and (1) 10mm Plastic Retainer, **(Figure 20A)**. Insert the Bolt Plate into the oval hole and up and out of the smaller round hole above it. Thread the Plastic Retainer onto the Bolt Plate over the top round hole to hold the Bolt Plate in place, **(Figure 20B)**.
 18. Locate the last (2) round holes along the floor panel, **(Figure 19)**. Repeat **Steps 3—5** to install the (2) Bolt Plates and Rear Lock Plate, **(Figures 21 & 22)**. **NOTE:** Attach the Lock Plate to the front Bolt Plate only with (1) 10mm Flat Washer, (1) 10mm Lock Washer and (1) 10mm Hex Nut, **(Figure 22)**. Tighten the Hex Nut at this time.
 19. Select the passenger side rear Frame Bracket, **(Figure 23)**. Attach the Frame Bracket to the Double Bolt Plate with (2) 10mm Flat Washers, (2) 10mm Lock Washers and (2) 10mm Hex Nuts, **(Figure 24)**. Do not tighten hardware at this time. Next, attach the driver side Rear Mounting Bracket to the front of the Frame Bracket with (2) 8mm Flat Washers, (2) 8mm Lock Washers and (2) 8mm Hex Nuts, **(Figure 25)**. Do not tighten hardware at this time.
 20. Select the passenger side "7" Rear Support Bracket, **(Figures 6A & 26)**. Attach the Support Bracket to the rear Bolt Plate with (1) 10mm Flat Washer, (1) 10mm Lock Washer and (1) 10mm Hex Nut, **(Figure 27)**. Do not tighten hardware. Attach the Mounting Bracket to the back of the "7" Rear Support Bracket with (1) 8mm x 30mm Hex Bolt, (2) 8mm Flat Washers, (1) 8mm Lock Washer and (1) 8mm Hex Nut, **(Figure 27)**. Do not tighten hardware at this time.
 21. Carefully un-wrap the Running Boards. Insert (6) 6mm T-Bolts into the open ends of the channels, (3 T-Bolts per channel), in the bottom of the Running Board, **(Figure 28)**. Hold the Running Board up in the approximate position and slide the T-Bolts down the channels to line up with the (3) Brackets. Tilt the Running Board up at a slight angle to clear the slots in the Brackets. Secure the Running Board to the Brackets with (6) 6mm Flat Washers, (6) 6mm Lock Washers and (6) 6mm Hex Nuts, **(Figure 29)**. **NOTE:** The Running Board is designed to fit close to the vehicle. It may be necessary to loosen the Mounting Brackets and tilt the Brackets downward to insert the Running Board. Do not fully tighten hardware at this time.
 22. Level and adjust the Running Board and tighten all hardware.
 23. Repeat **Steps 2—22** for driver side Running Board installation.
 24. Do periodic inspections to the installation to make sure that all hardware is secure and tight.

To protect your investment, wax this product after installing. Regular waxing is recommended to add a protective layer over the finish. Do not use any type of polish or wax that may contain abrasives that could damage the finish. Aluminum polish may be used to polish small scratches and scuffs on the finish. Only use mild soap to clean the Running Board.

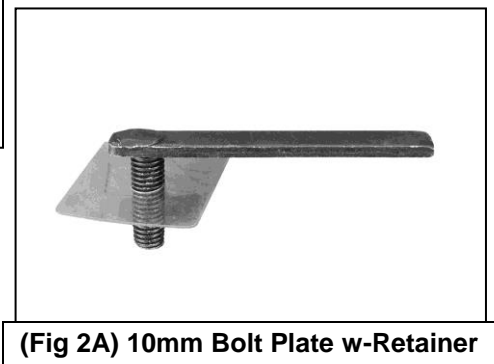
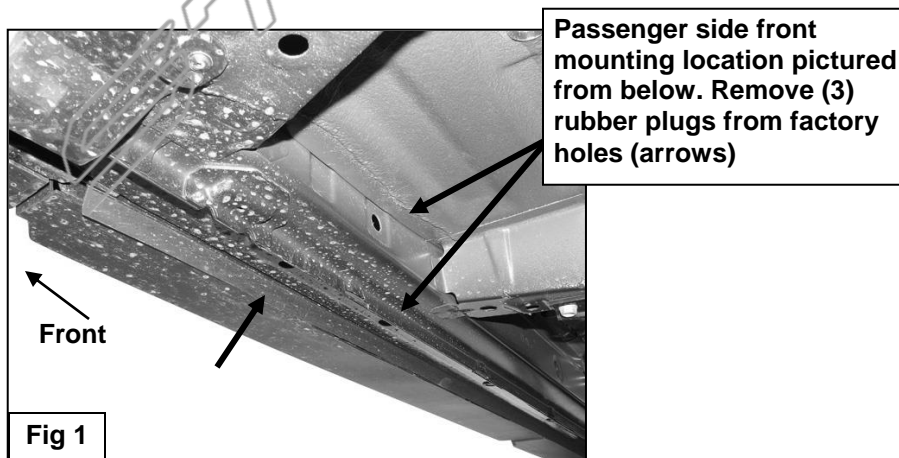

Passenger Side Installation Pictured

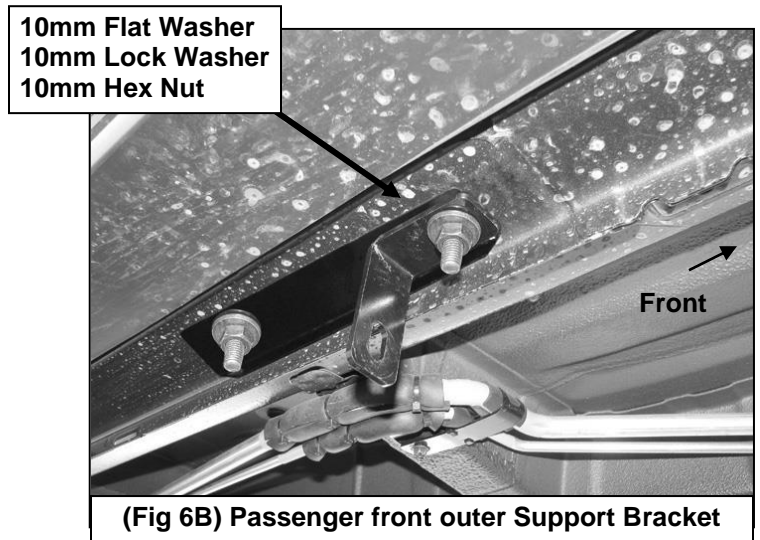
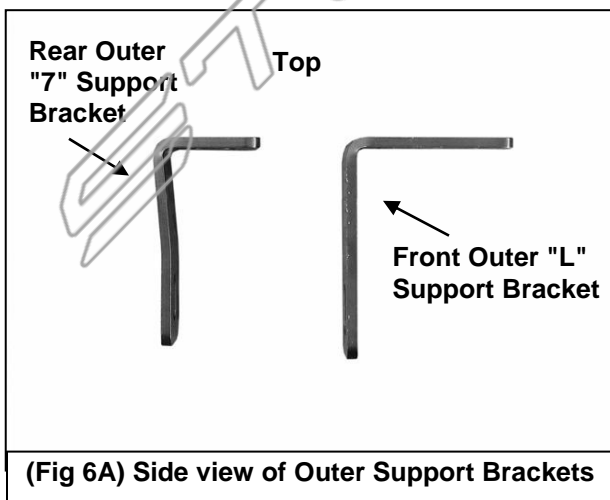
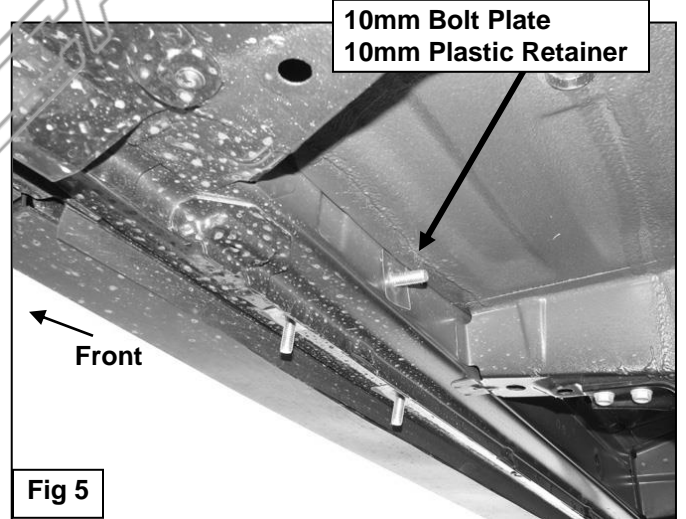
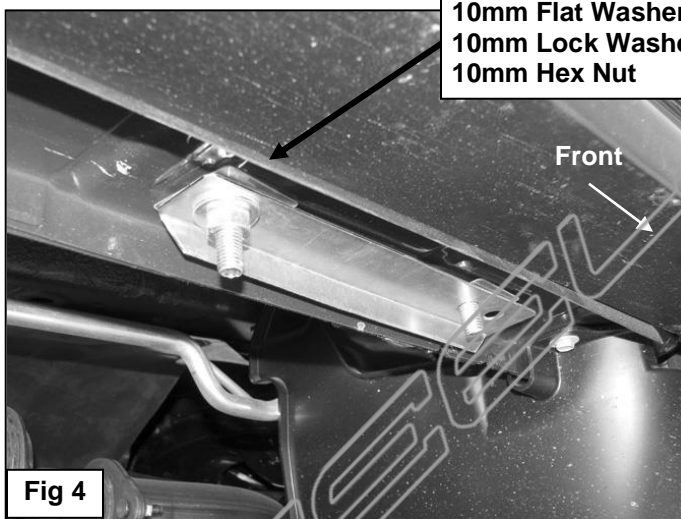
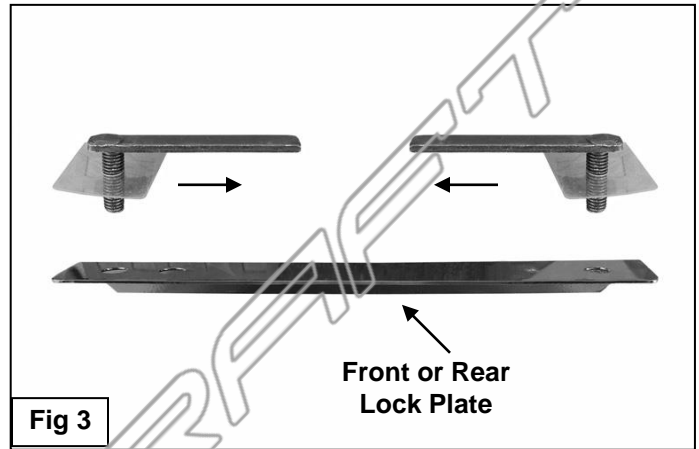
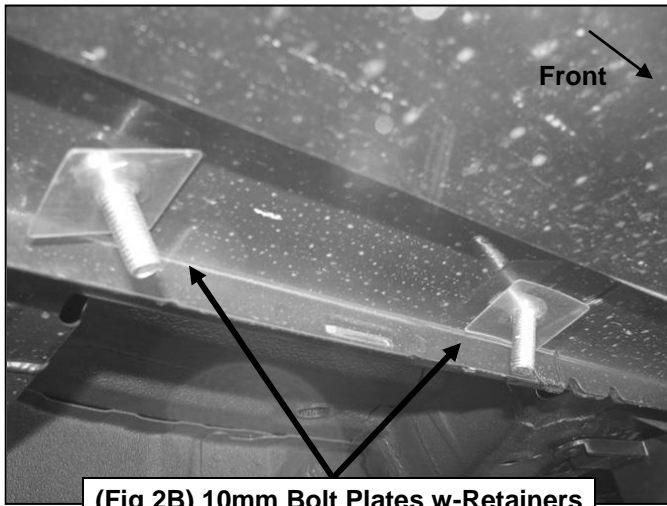

Passenger Side Installation Pictured

10mm Flat Washer
10mm Lock Washer
10mm Hex Nut

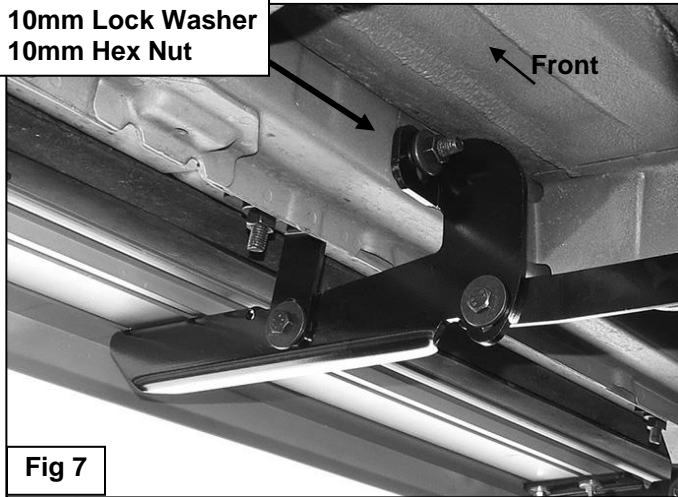

Fig 7

10mm Flat Washer
10mm Lock Washer
10mm Hex Nut

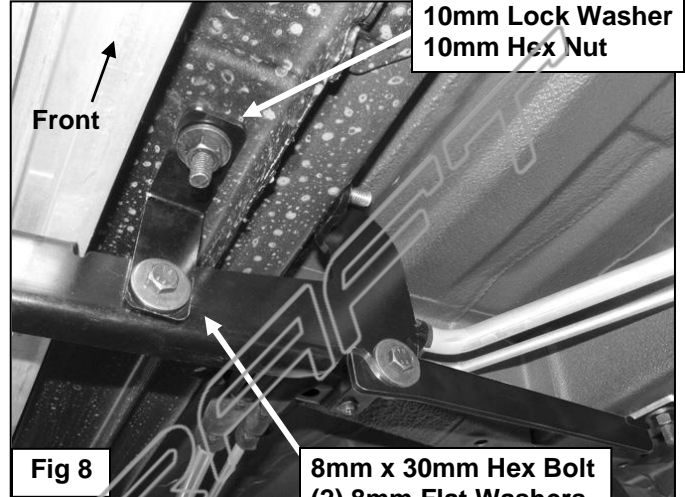
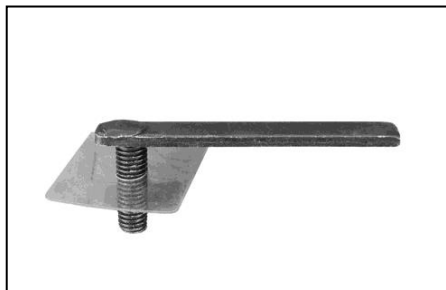

Fig 8

8mm x 30mm Hex Bolt
(2) 8mm Flat Washers
8mm Lock Washer
8mm Hex Nut



(Fig 9) 10mm Bolt Plate w-Retainer

10mm Bolt Plate
10mm Plastic Retainer
10mm Flat Washer
10mm Lock Washer
10mm Hex Nut

Passenger/right inner
location pictured. Install
Bolt Plate in 2nd hole
behind tie down loop

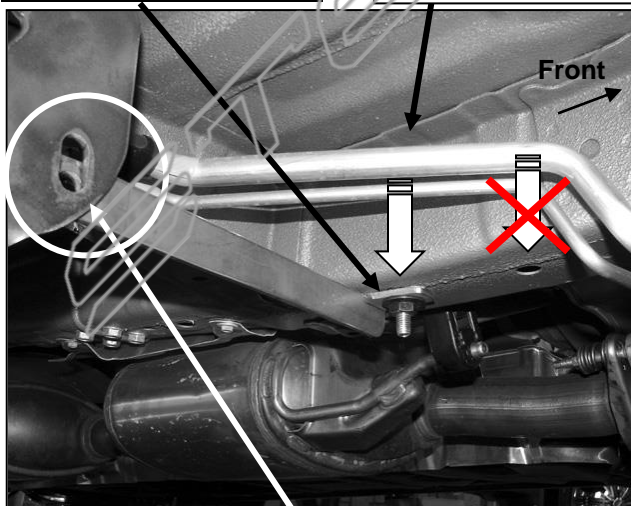

(Fig 11) Passenger/Right inner location pictured. Bolt Support Bracket to back of Front Bracket

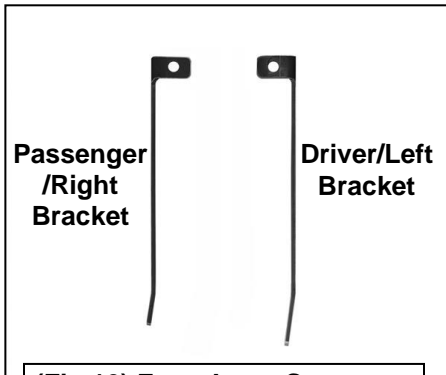

(Fig 10) Front Inner Support Brackets pictured from above

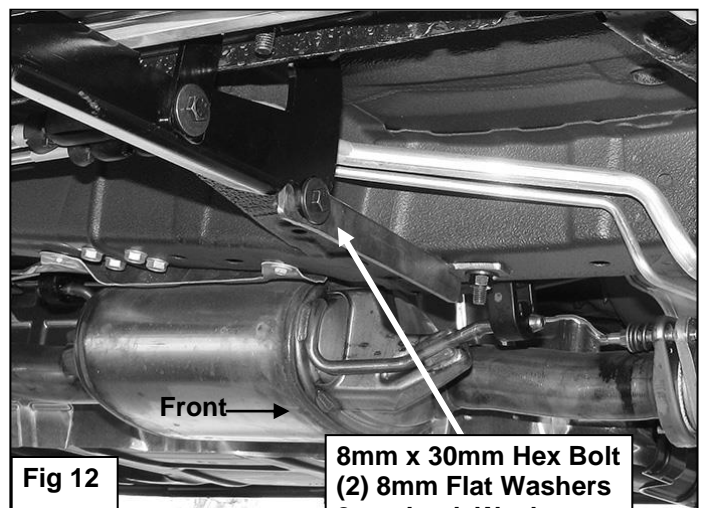
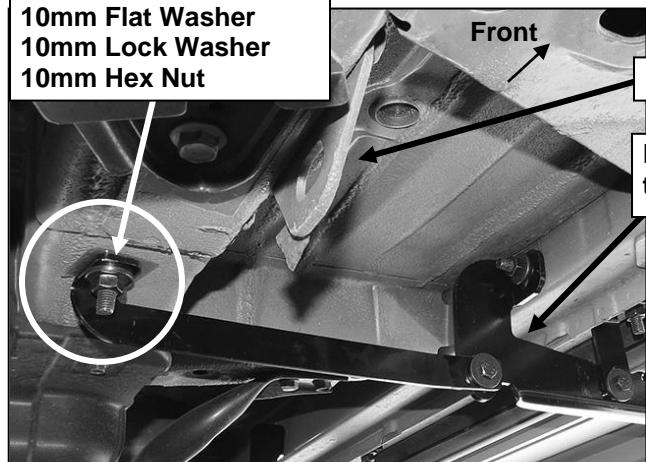

Fig 12

8mm x 30mm Hex Bolt
(2) 8mm Flat Washers
8mm Lock Washer
8mm Hex Nut

Passenger Side Installation Pictured

- 10mm Bolt Plate
- 10mm Plastic Retainer
- 10mm Flat Washer
- 10mm Lock Washer
- 10mm Hex Nut



(Fig 13) Driver/Left front inner location pictured. Use hole closest to tie down loop

- 10mm Flat Washer
- 10mm Lock Washer
- 10mm Hex Nut

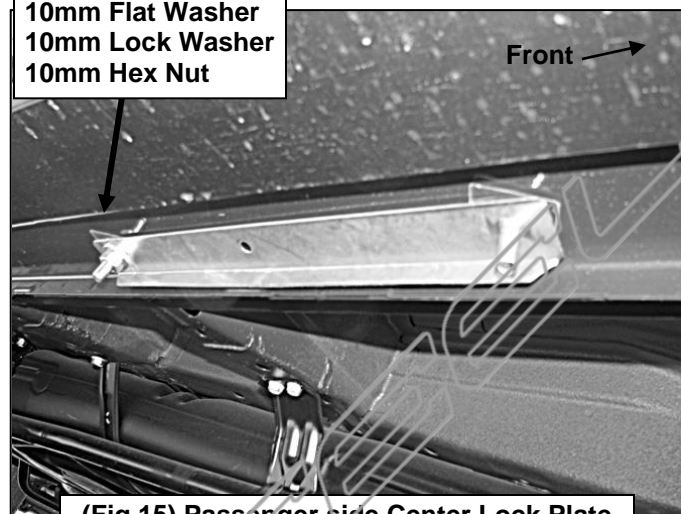

(Fig 15) Passenger side Center Lock Plate

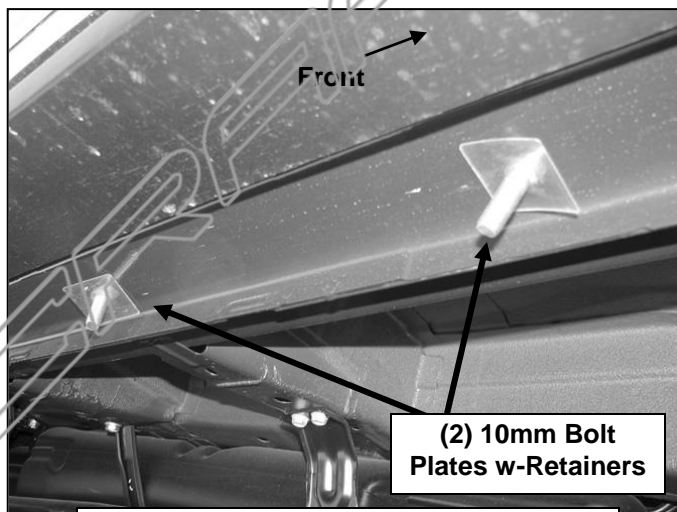

(Fig 14) Passenger side center location

- 10mm Bolt Plate (see Fig 2A & 9)

Center Lock Plate

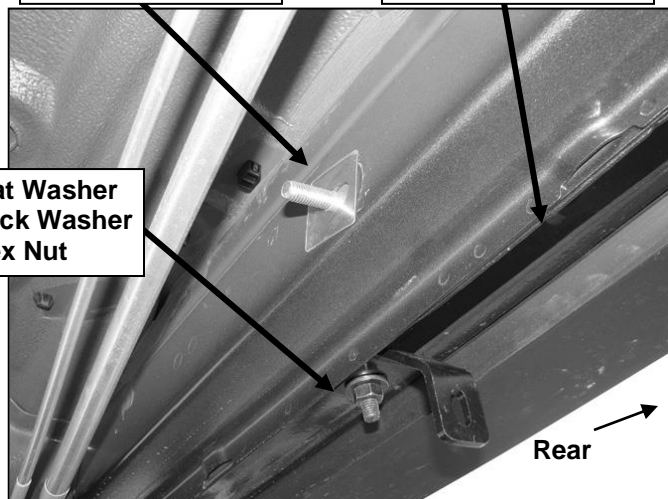

(Fig 16B) Passenger side center Support Bracket

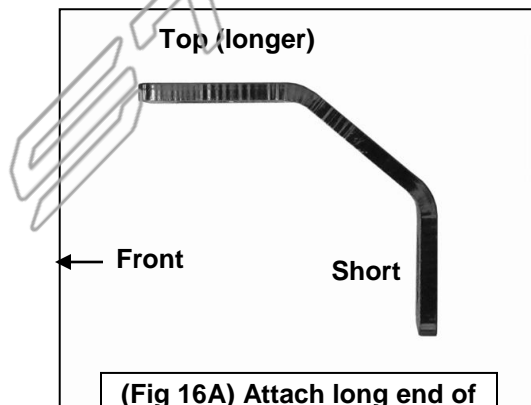

(Fig 16A) Attach long end of Support Bracket to Bolt Plate

Passenger Side Installation Pictured



10mm Flat Washer
10mm Lock Washer
10mm Hex Nut

Fig 17

8mm x 30mm Hex Bolt
(2) 8mm Flat Washers
8mm Lock Washer
8mm Hex Nut

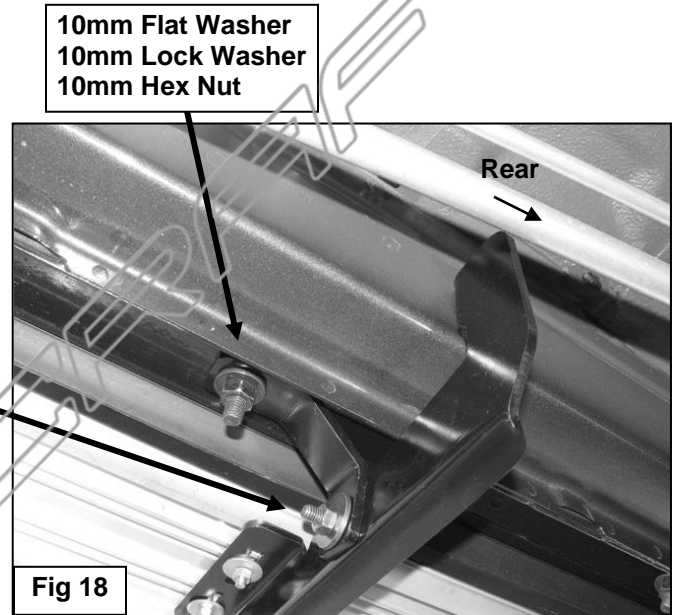

10mm Flat Washer
10mm Lock Washer
10mm Hex Nut

Fig 18

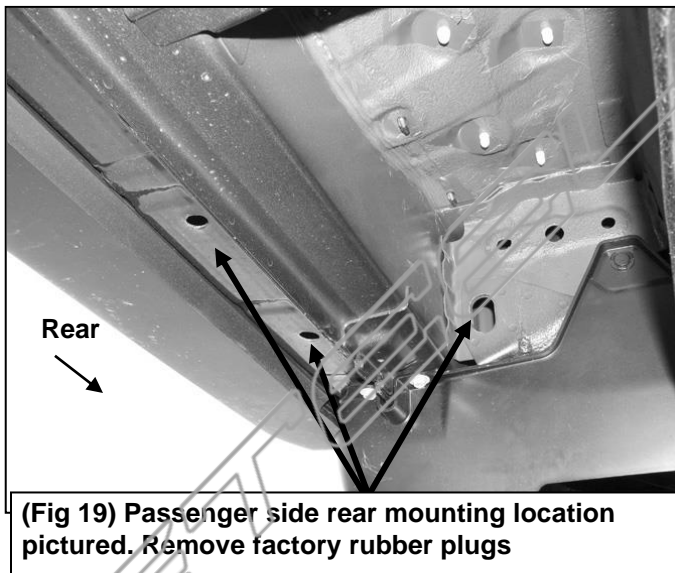

(Fig 19) Passenger side rear mounting location pictured. Remove factory rubber plugs



(Fig 20A) 10mm Double Bolt Plate

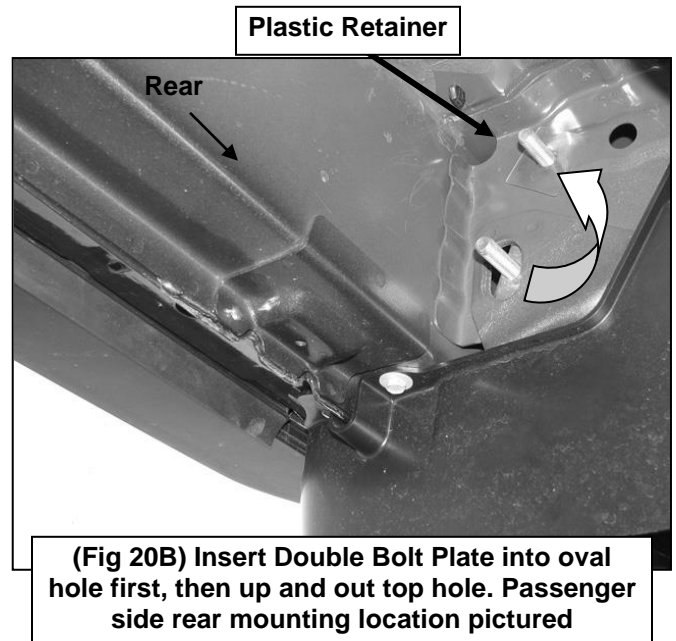

Plastic Retainer

(Fig 20B) Insert Double Bolt Plate into oval hole first, then up and out top hole. Passenger side rear mounting location pictured

Passenger Side Installation Pictured

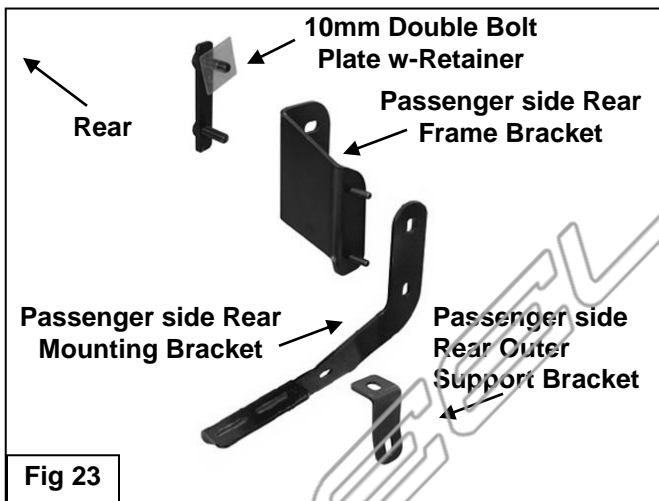
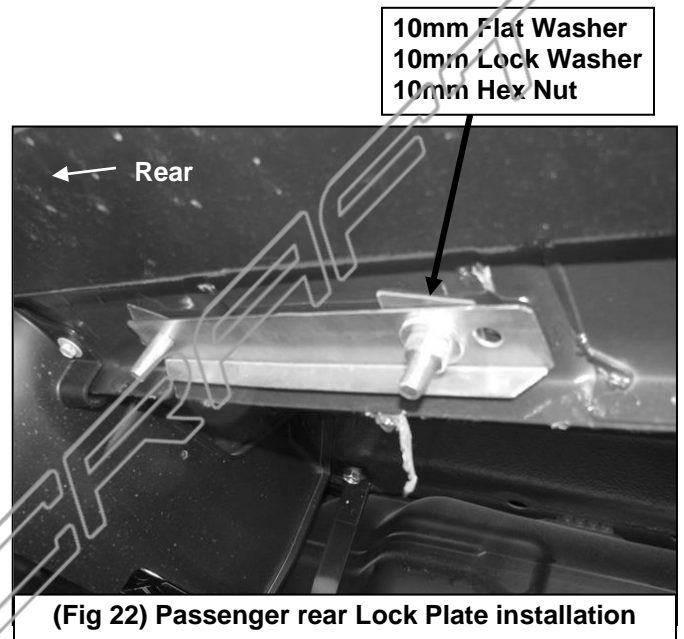
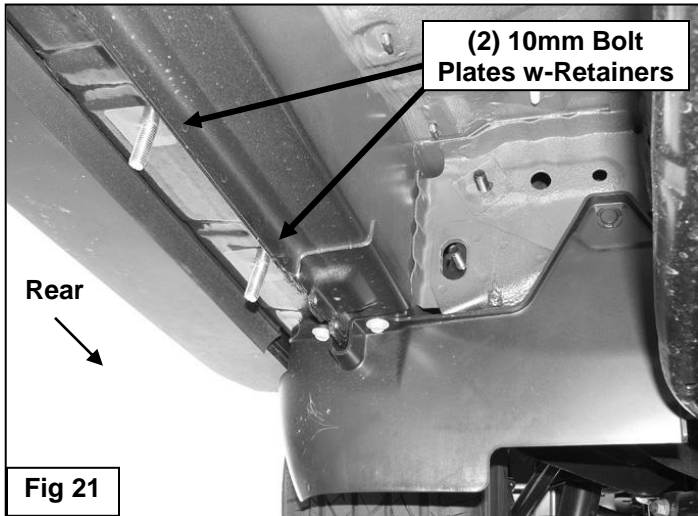

(2) 10mm Flat Washers
(2) 10mm Lock Washers
(2) 10mm Hex Nuts

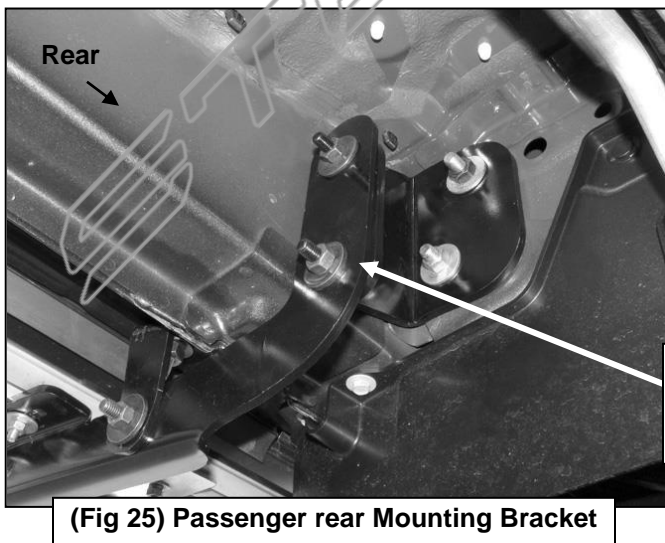
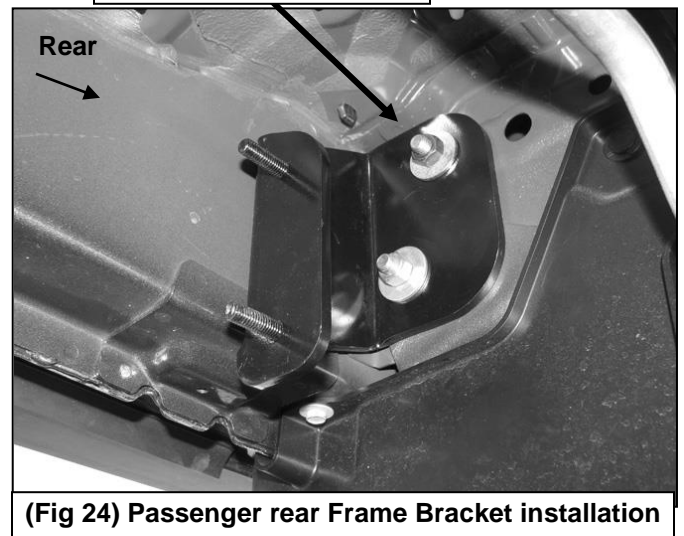

(2) 8mm Flat Washers
(2) 8mm Lock Washers
(2) 8mm Hex Nuts

Passenger Side Installation Pictured

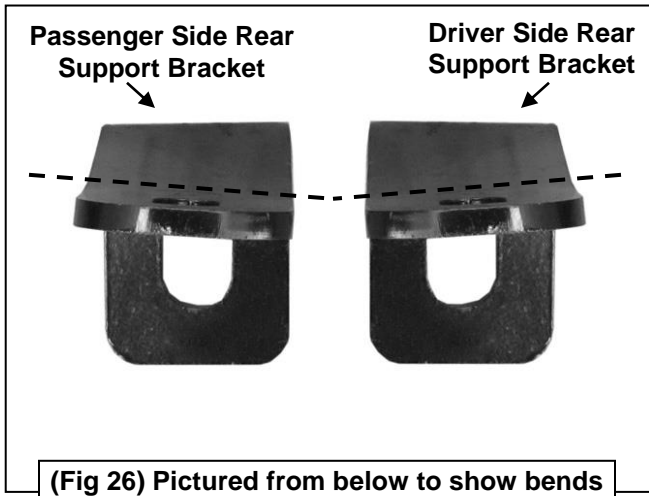

8mm x 30mm Hex Bolt
(2) 8mm Flat Washers
8mm Lock Washer
8mm Hex Nut

10mm Flat Washer
10mm Lock Washer
10mm Hex Nut

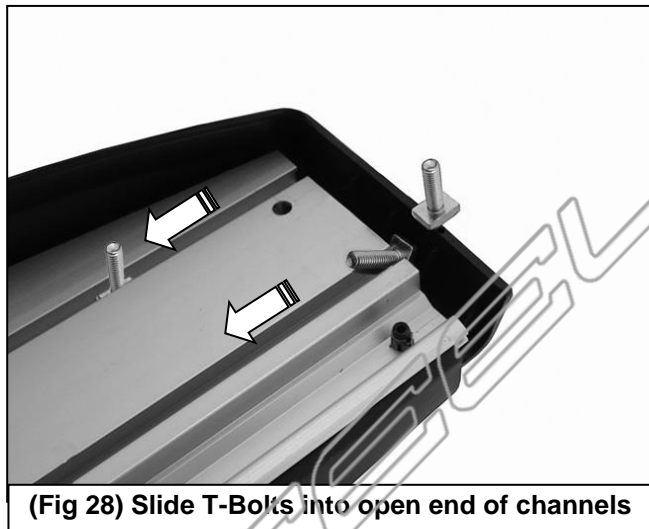
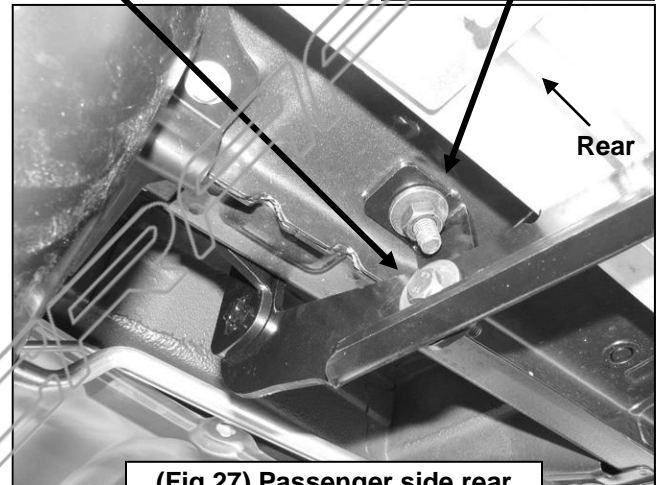

8mm x 30mm Hex Bolt
(2) 8mm Flat Washers
8mm Lock Washer
8mm Hex Nut

6mm T-Bolts
6mm Flat Washers
6mm Lock Washers
6mm Hex Nuts

