

INSTALLATION INSTRUCTIONS
SIDEBAR
07-10 GMC ACADIA / 09-10 CHEVY TRAVERSE
PART NUMBER

PARTS LIST:

1	Driver/Left Sidebar	12	8-1.25mm x 25mm Hex Head Bolts
1	Passenger/Right Sidebar	10	8mm Lock Washers
1	Driver/Left Front Mounting Bracket	10	8mm ID x 22mm OD x 1.5mm Flat Washers
1	Passenger/Right Front Mounting Bracket	6	12mm Square Washers
1	Driver/Left Rear Mounting Bracket	6	12mm Lock Washers
1	Passenger/Right Rear Mounting Bracket	6	12mm Hex Nuts
2	8mm "Z" Brackets	6	12-1.75mm x 45mm Bolt Plates
		6	12mm ID x 29mm OD x 3mm Flat Washers

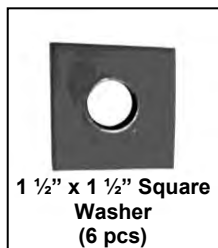
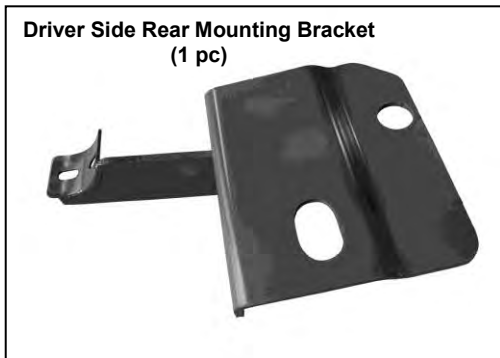
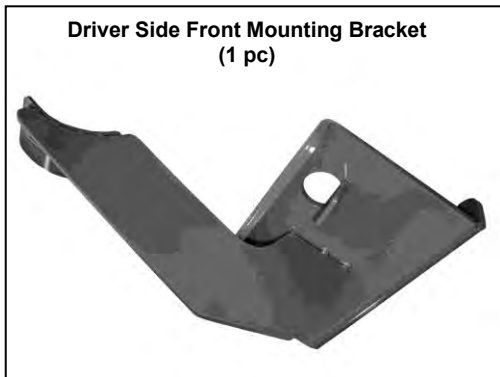

PROCEDURE:

1. REMOVE CONTENTS FROM BOX. VERIFY ALL PARTS ARE PRESENT. READ INSTRUCTIONS CAREFULLY BEFORE STARTING INSTALLATION.
2. On the passenger side, locate the three factory holes on the floor panel rail towards the front of the vehicle. There is an oval and a round factory hole on the bottom floor panel rail and a round factory hole on the side of the floor panel rail.
3. Insert (1) 12mm x 45mm Bolt Plate into the slotted factory hole (**Figure 1**). **NOTE:** Do not center the Bolt Plate in the factory hole, the shorter end of Bolt Plate should be pushed to one side of the factory hole in order to fully engage.
4. Position passenger side front Mounting Bracket up to the vehicle and over already inserted Bolt Plate. **NOTE:** The hole pattern on the Mounting Bracket matches the hole pattern on the vehicle. Partially hang Mounting Bracket to Bolt plate using the included (1) 12mm Hex Nut and (1) 12mm Square Washer (**Figure 1**).
5. Insert "Z" Bracket through the bottom rounded hole in Mounting Bracket and through factory hole located on the bottom of the floor panel rail as shown in figure 2. Orient "Z" Bracket to the factory hole located on the side of the floor panel rail (**Figure 2**).
6. Secure the side of the Mounting Bracket to the side of the floor panel rail using the included (1) 8mm x 25mm Hex Head Bolt, (1) 8mm Lock Washer, and (1) 8mm Flat Washer (**Figure 3 & 4**). Hand tighten at this time.
7. Attach the opposite end of "Z" Bracket to the tab on the Mounting Bracket using the included (1) 8mm x 25mm Hex Head Bolt (**Figure 4 & 5**). Hand tighten at this time.
8. Locate the slotted and the rounded hole towards the rear of the floor panel rail. **NOTE:** There are three round holes towards the rear of the floor panel rail, two large and a small one. Use the larger hole towards the front of the vehicle. Insert (1) 12mm x 45mm Bolt Plate into each of the factory holes (**Figure 6**). **NOTE:** Do not center the Bolt Plate in the factory hole, the shorter end of Bolt Plate should be pushed to one side of the factory hole in order to fully engage.
9. Position passenger side Rear Mounting Bracket up to the vehicle and over the already inserted Bolt Plates. Partially hang Mounting Bracket to Bolt Plates using the included (2) 12mm Square Washers and (2) 12mm Hex Nuts (**Figure 7**). Hand tighten at this time.
10. Position passenger Sidebar onto Mounting Brackets. Attach Sidebar to Mounting Brackets using the included (4) 8mm x 25mm Hex Head Bolts, (4) 8mm Lock Washers, and (4) 8mm Flat Washers (**Figure 8**).
11. Level and adjust Sidebar properly; and then tighten all hardware at this time. **IMPORTANT!** Do not move the Mounting Brackets too much when adjusting the Sidebar; this may cause Bolt Plates to disengage.
12. Repeat steps 2 – 13 for driver Sidebar.
13. Do periodic inspections to the installation to make sure that all hardware is secure and tight.

Passenger Side Front Mounting Bracket Shown

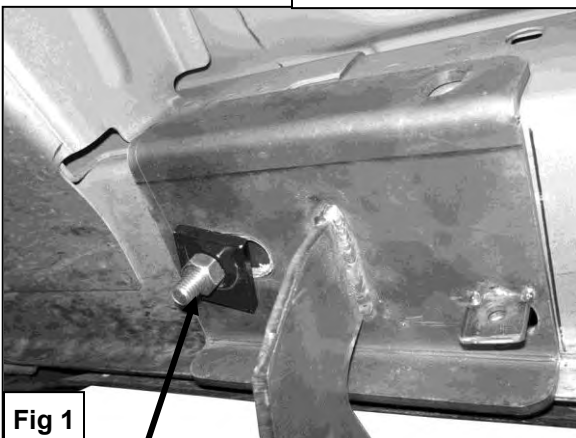

Fig 1

12mm x 45mm Bolt Plate
12mm Square Washer
12mm Hex Nut
12mm Flat Washer

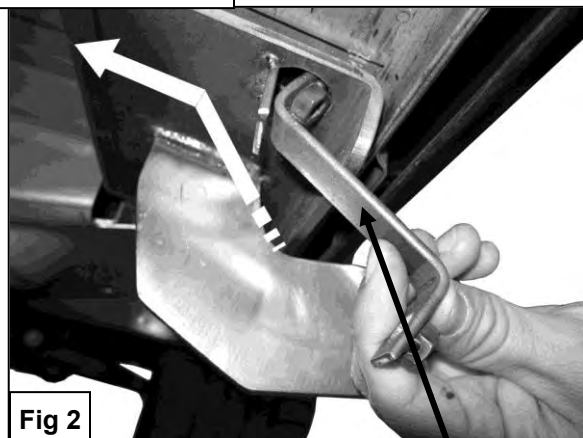
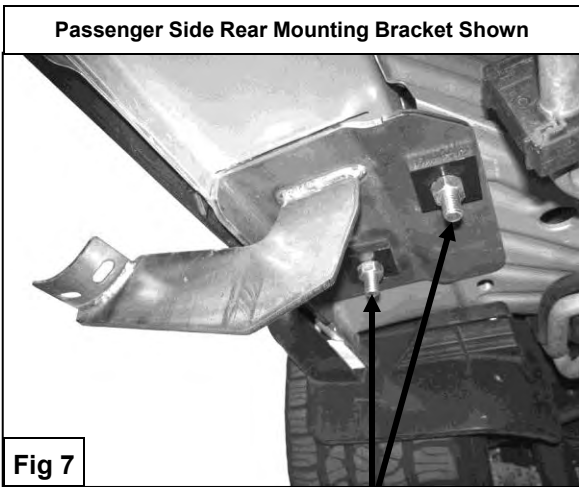
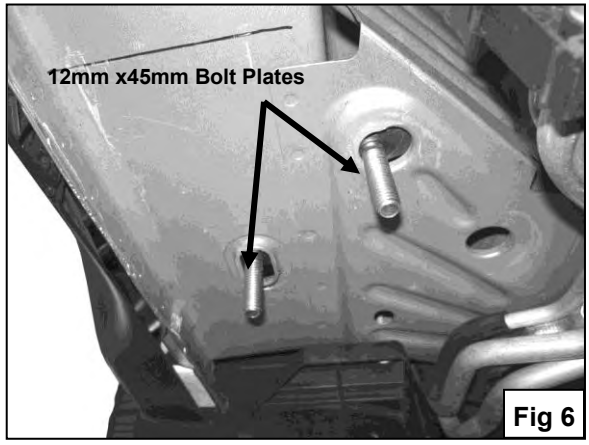
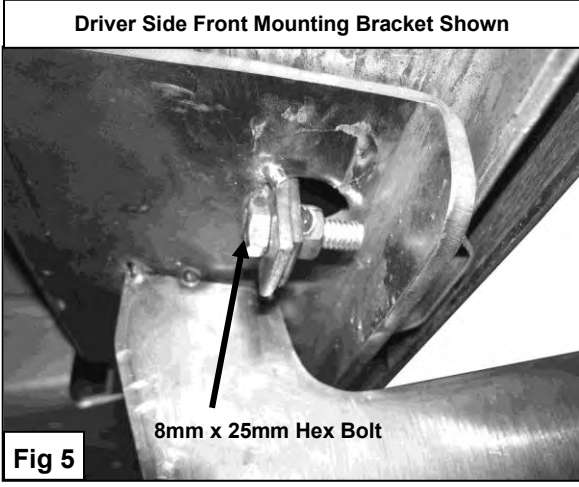
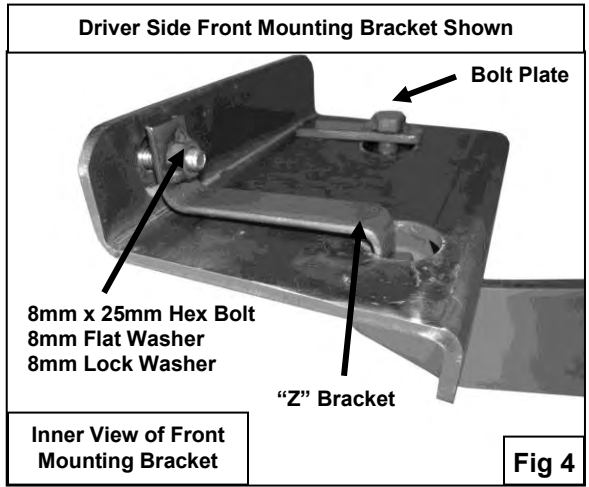
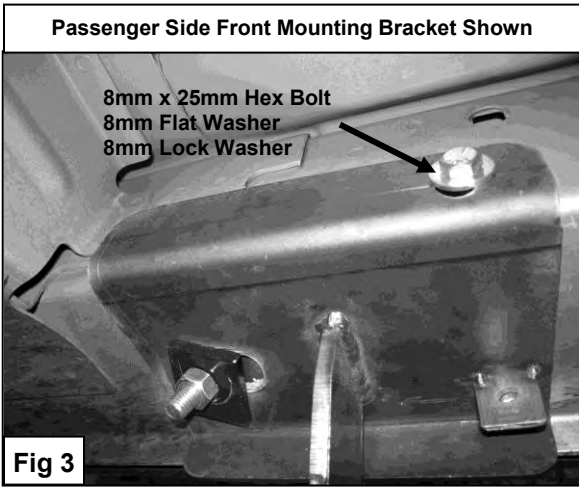

Fig 2

Insert "Z" Bracket
as shown



(Bolt Plates)
12mm Square Washer
12mm Hex Nut
12mm Flat Washer

8mmx 25mm Hex Bolts
8mm Lock Washers
8mm Flat Washers