

# INSTALLATION INSTRUCTIONS

## SIDEBAR

### 04-06 TOYOTA TUNDRA EXT CAB

#### PART #

**PARTS LIST:**

1	Driver/Left Sidebar	4	1/2" x 2" Hex Head Bolts
1	Passenger/Right Sidebar	4	1/2" Lock Washers
1	Driver/Left Front Mounting Bracket	4	1/2" ID x 1 3/8" OD x 3/32" Flat Washers
1	Driver/Left Front Support Bracket	2	12-1.75mm x 140mm Hex Head Bolts
1	Driver/Left Rear Mounting Bracket	2	12-1.75mm x 40mm Hex Head Bolts
1	Passenger/Right Front Mounting Bracket	4	12mm Lock Washers
1	Passenger/Right Front Support Bracket	4	12mm Hex Nuts
1	Passenger/Right Rear Mounting Bracket	8	12mm ID x 29mm OD x 3mm Flat Washers
2	Tube Spacers (19mm x 95mm)	2	10-1.50mm X 30mm Hex Head Bolts
2	Square Washers	2	10mm Lock Washers
		2	10mm Hex Nuts
		4	10mm ID x 26mm OD x 3mm Flat Washers

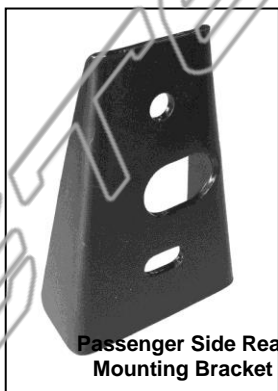
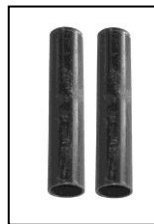
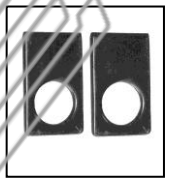
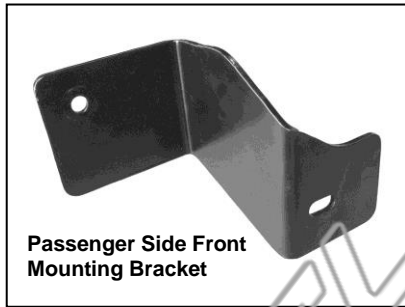

## PROCEDURE:

1. REMOVE CONTENTS FROM BOX. VERIFY ALL PARTS ARE PRESENT. READ INSTRUCTIONS CAREFULLY BEFORE STARTING INSTALLATION.
2. From underneath of vehicle, locate the rectangular factory hole in the frame by the front body mount (**Figure 1**).
3. Starting on the driver side front, position the Mounting Bracket up to frame. Line up the hole in the Bracket with factory rectangular hole in the frame. Insert (1) 12mm x 140mm Hex Head Bolt with (1) 12mm Flat Washer through Mounting Bracket and frame (**Figure 2**). From opposite side of frame insert (1) Tube Spacer and push it into frame (**Figure 3**), then slide on one of the Square Washers to cover square hole in frame (**Figure 4**), followed by (1) 12mm Flat Washer, (1) 10mm Lock Washer, and (1) 10mm Hex Nut, hand tighten at this time (**Figure 5**).
4. Locate the two factory holes in the upper body mount cavity (**Figure 1**), partially mount the driver side front Support Bracket to front hole using the included (1) 10mm x 30mm Hex Head Bolt, (1) 10mm Lock Washer, (1) 10mm Hex Nut, and (2) 10mm Flat Washers (**Figure 6**).
5. Hand tighten driver side rear Mounting Bracket to driver Sidebar using the included (1) ½" x 2" Hex Head Bolt, (1) ½" Lock Washer, (1) ½" Flat Washer (**Figure 7**); then attach Bracket with already installed Sidebar to factory hole in the lower body mount cavity using the included (1) 12mm x 40mm Hex Head Bolt, (1) 12mm Lock Washer, (1) 12mm Hex Nut, and (2) 12mm Flat Washers (**Figure 8 & 9**). **NOTE:** The longer leg on the Sidebar mounts to the rear. Do not tighten at this time.
6. Attach front end of driver Sidebar to already installed Mounting Bracket and Support Bracket using the included (1) ½" x 2" Hex Head Bolt, (1) ½" Lock Washer, (1) ½" Flat Washer (**Figure 10**).
7. Level and adjust Sidebar properly; and then tighten all hardware at this time.
8. Repeat steps 2 – 7 for passenger Sidebar.
9. Do periodic inspections to the installation to make sure that all hardware is secure and tight.

**To protect your investment**, wax this product after installing. Regular waxing is recommended to add a protective layer over the finish. Do not use any type of polish or wax that may contain abrasives that could damage the finish.

**For stainless steel:** Aluminum polish may be used to polish small scratches and scuffs on the finish. Mild soap may be used also to clean the Sidebar.

**For gloss black finishes:** Mild soap may be used to clean the Sidebar.

### (Driver Side Installation Shown)

