

**PARTS LIST:**

Qty	Description	Qty	Description
1	Grille Guard	4	12-1.75mm Nylon Lock Nuts
1	Driver/left Frame Mounting Bracket	4	10-1.5mm x 30mm Hex Bolts
1	Passenger/right Frame Mounting Bracket	10	10mm x 24mm OD x 2.2mm Flat Washers
1	Driver/left Support Bracket	6	10-1.5mm Nylon Lock Nuts
1	Passenger/right Support Bracket	2	8-1.25mm x 30mm Hex Bolts
4	Spacers (models without tow hooks only)	4	8mm x 22mm OD x 2mm Flat Washers
2	12-1.75mm x 100mm Double Bolt Plates	2	8-1.25mm Nylon Lock Nuts
4	12mm x 32mm OD x 3mm Flat Washers		

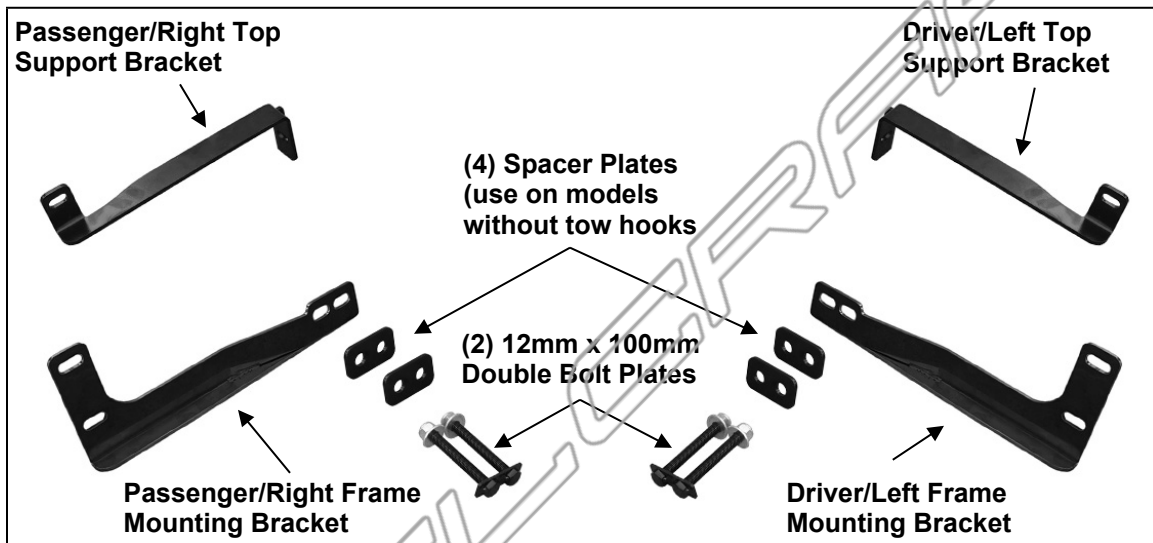

**PROCEDURE:**

**REMOVE CONTENTS FROM BOX AND VERIFY ALL PARTS ARE PRESENT. READ INSTRUCTIONS CAREFULLY. ASSISTANCE IS RECOMMENDED. CUTTING IS REQUIRED. INSTALLATION MAY INTERFERE WITH FRONT MOUNTED SENSORS.**

1. Start installation from under the front of the vehicle. Remove the plastic splash guard from below-behind bumper, **(Figure 1)**. Also, it may be necessary to temporarily remove the factory skid plate, (if equipped), to access the mounting locations. With assistance, remove the plastic front bumper cover, **(Figures 2A—2D)**. Move the cover to clean area to avoid damage to the finish.
2. Locate the plastic air deflector attached to the top of the steel impact bumper, **(Figure 3)**. Select the passenger side Top Bracket. Locate the outer top mounting bolt attaching the bumper to the frame, **(Figure 4)**. **NOTE:** The Top Bracket attaches to the back of the steel bumper over the factory bolt. Use removable tape to mark the path the bracket will take through the air deflector, **(Figure 3)**. Use a sharp knife or hacksaw blade to enlarge the opening in the deflector to clear the top bracket. Only remove enough of the plastic to clear the Bracket, **(Figure 5)**. Repeat this Step to cut the opening for the driver side Top Bracket.
3. Determine if the vehicle is equipped with tow hooks.
 

**Models without tow hooks:**

  - a. Openings in the bumper cover must be cut out to clear the Frame Brackets. Cut along the factory cut lines molded into both pockets in the cover, **(Figure 6)**. This can be done when the bumper cover has been removed or after reinstallation on the vehicle.

**Models with tow hooks:**

  - a. Remove both tow hooks and seals around tow hooks, **(Figure 7)**.
4. Once both sides of the air deflector are cut, reinstall the front bumper cover only. With the cover back in place, select the passenger side Frame Mounting Bracket. Insert the Bracket through the opening in the bumper and up to the tow hook mounting holes, **(Figure 8)**. Trim the plastic as required for Frame Bracket clearance.

**Models without tow hooks:**

- a. Select the 12mm Double Bolt Plate and (2) Spacers, (**Figures 9 & 11**). Insert the Bolt Plate from the inside out through the frame. Slide the (2) Spacers over the threaded end of the Bolt Plate, (**Figure 10**). Slide the Bracket over the Bolt Plate and Spacers, (with Spacers between frame and Bracket), and attach with (2) 12mm Flat Washers and (2) 12mm Nylon Lock Nuts, (**Figure 11**). Do not fully tighten hardware at this time.
- b. Repeat to install the driver side frame Bracket.

**Models with tow hooks:**

- a. Replace the factory tow hook hardware with the included longer 12mm Double Bolt Plate, (**Figures 9 & 11**). Reinstall the tow hook over the frame. Insert the 12mm Double Bolt Plate through the tow hook and frame, (**Figure 12**). Slide the Bracket over the Bolt Plate and secure the Bracket to the tow hook with (2) 12mm Flat Washers and (2) 12mm Nylon Lock Nuts. Do not fully tighten hardware at this time. **NOTE:** Spacers are not required when reinstalling the tow hooks.
  - b. Repeat to install the driver side frame Bracket.
5. With assistance, hold the Grille Guard up in position on the outside of the Mounting Brackets. Bolt the Grille Guard to the Brackets with (4) 10mm x 30mm Hex Bolts, (8) 10mm Flat Washers and (4) 10mm Nylon Lock Nuts, (**Figure 13**). Do not tighten hardware at this time.
  6. Select the passenger side Top Bracket, (**Figures 14A & 15**). Slide the bracket into the lower grille opening and back into position behind the steel bumper. Attach the Bracket to the bumper bolt with (1) 10mm Flat Washer and (1) 10mm Nylon Lock Nut. Line up the outer (forward) end of the Bracket with the hole in the upright on the Grille Guard. Attach the Bracket to the Grille Guard with (1) 8mm x 30mm Hex Bolt, (2) 8mm Flat Washers and (1) 8mm Nylon Lock Nut, (**Figures 14B & 15**). Snug but do not fully tighten hardware at this time. Repeat this Step to install the driver side Top Bracket.
  7. Check the Grille Guard alignment with the vehicle. Align and adjust as required then fully tighten all hardware at this time.
  8. Reinstall the plastic splash guard and/or skid plate removed in **Step 1, (Figure 1)**.
  9. Do periodic inspections to the installation to make sure that all hardware is secure and tight.

**To protect your investment**, wax this product after installing. Regular waxing is recommended to add a protective layer over the finish. Do not use any type of polish or wax that may contain abrasives that could damage the finish.

**For stainless steel:** Aluminum polish may be used to polish small scratches and scuffs on the finish. Mild soap may be used also to clean the Grille Guard.

**For gloss black finishes:** Mild soap may be used to clean the Grille Guard.

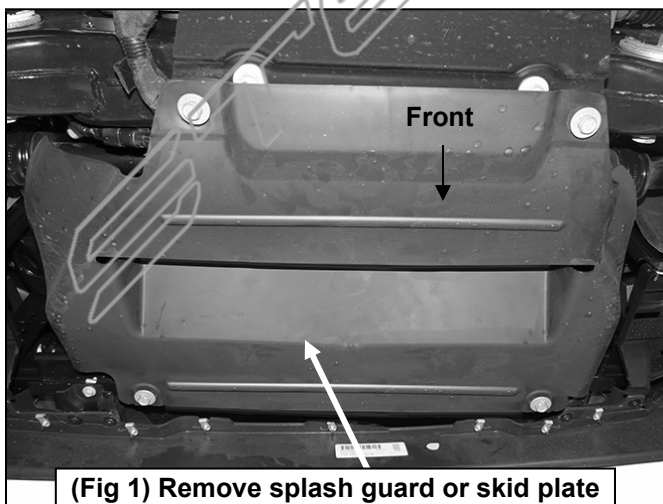

(Fig 1) Remove splash guard or skid plate from bottom of engine behind bumper

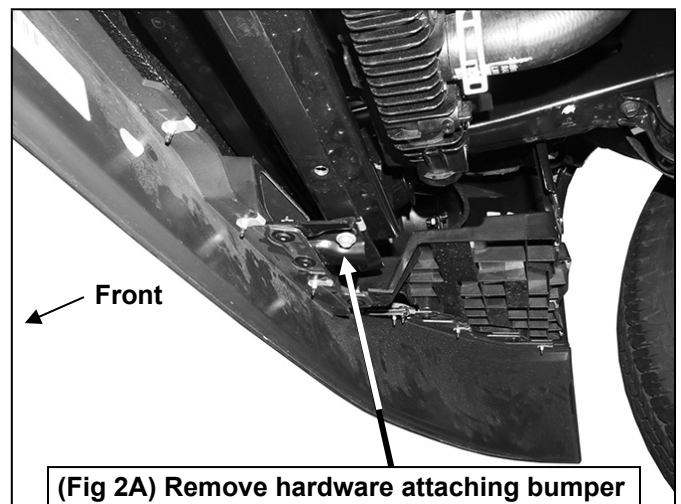

(Fig 2A) Remove hardware attaching bumper cover to cross member behind bumper



**(Fig 2B) Remove hardware attaching plastic fill panel to inner fender**



**(Fig 2C) Remove hardware attaching fender liner to bumper cover**

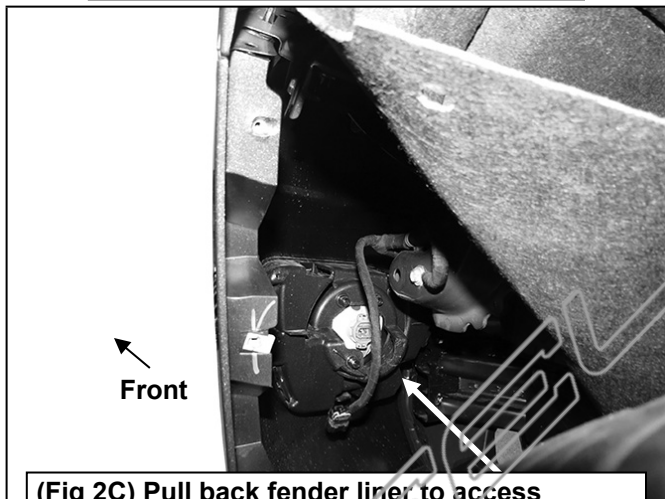

**(Fig 2C) Pull back fender liner to access bumper hardware and unplug light if equipped**

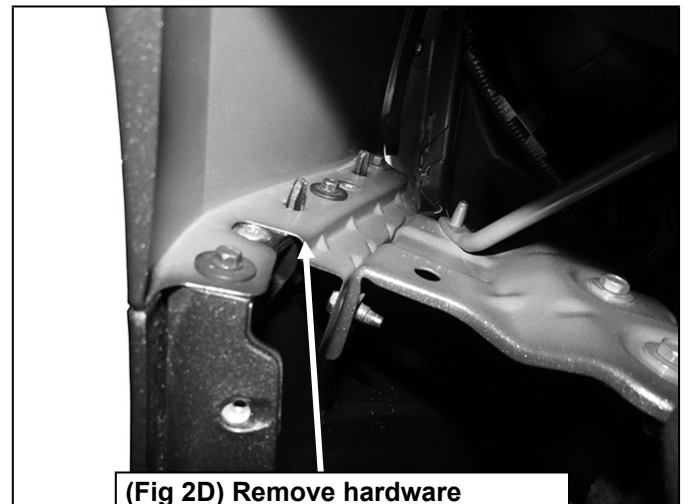

**(Fig 2D) Remove hardware attaching bumper cover to fender**



**(Fig 3) Hold Top Bracket in place to determine area to cut from air deflector (dashed lines for instruction purposes only)**

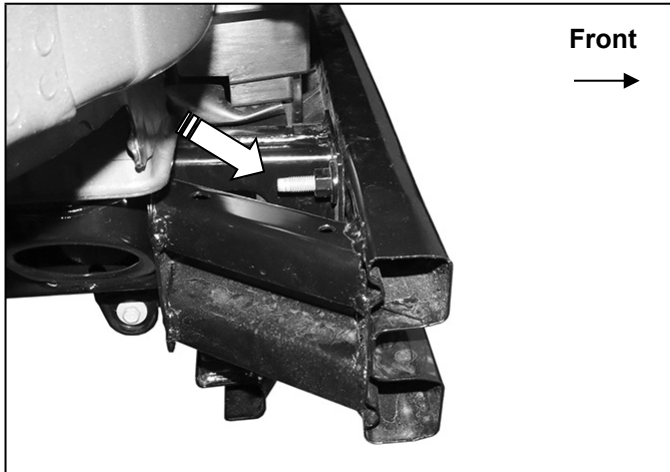

(Fig 4) Top Bracket attaches over factory bolt (arrow).  
Air deflector removed for instruction purposes



(Fig 5) Air deflector cut to clear Bracket

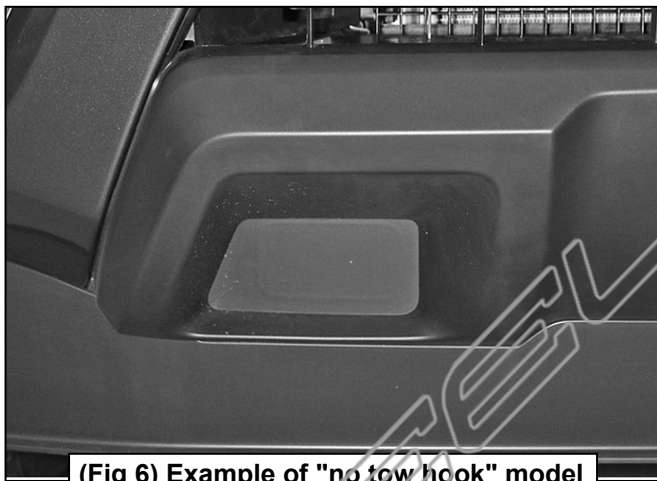

(Fig 6) Example of "no tow hook" model

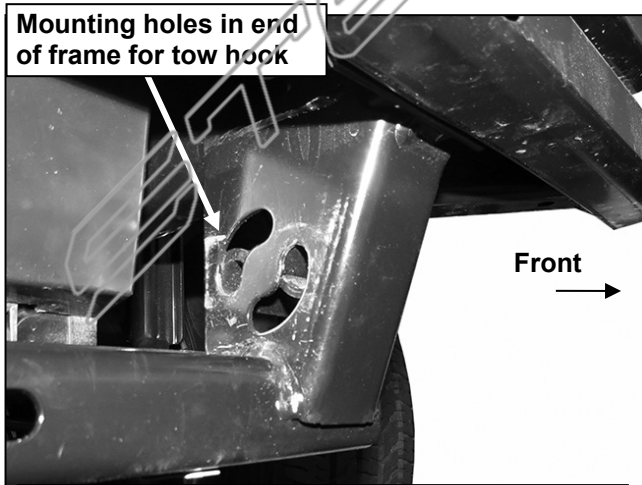

(Fig 8) Driver side tow hook mounting location



(Fig 7) Cut opening to clear Bracket

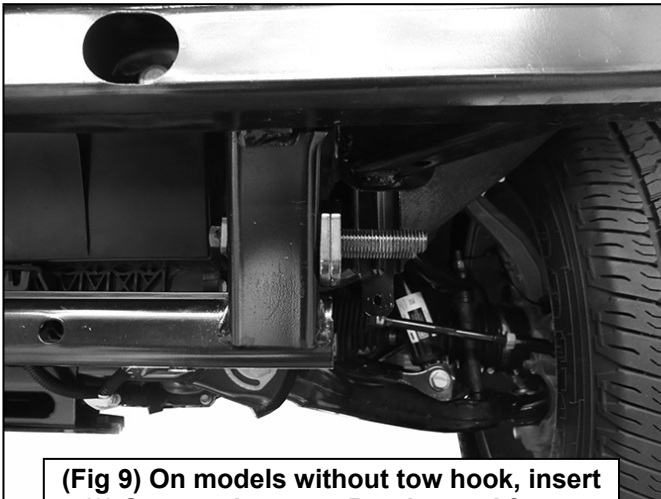

(Fig 9) On models without tow hook, insert (2) Spacers between Bracket and frame

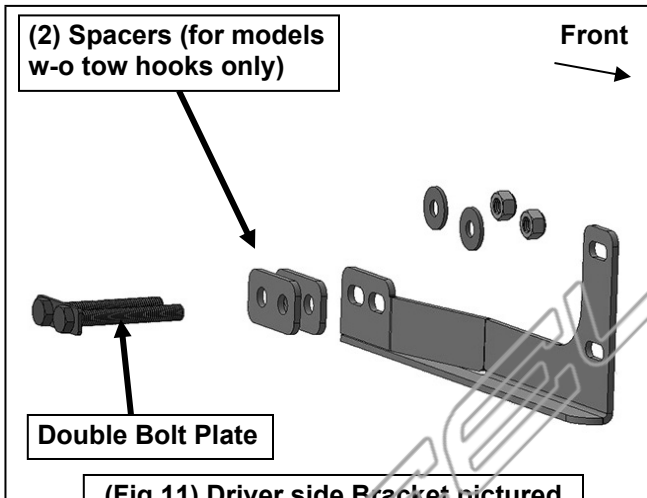

(Fig 11) Driver side Bracket pictured

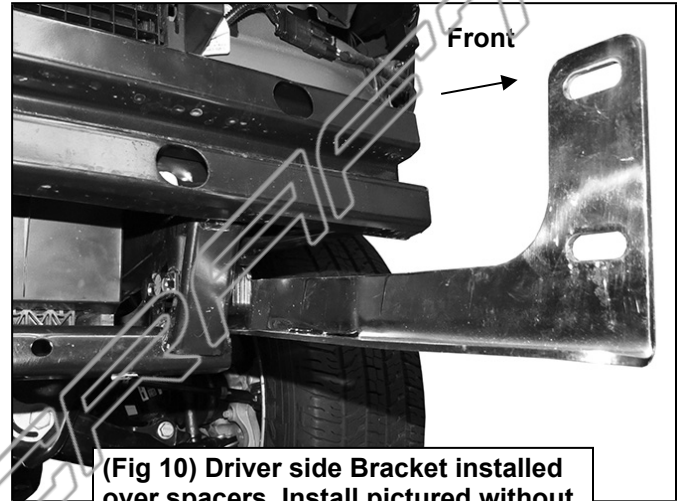

(Fig 10) Driver side Bracket installed over spacers. Install pictured without bumper for instruction purposes only

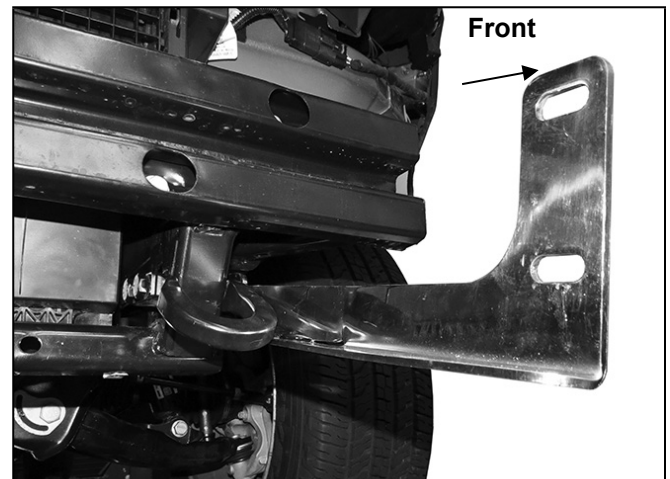

(Fig 12) Driver side Bracket installed over tow hook, Spacers are not required. Installation pictured without bumper for instruction purposes only

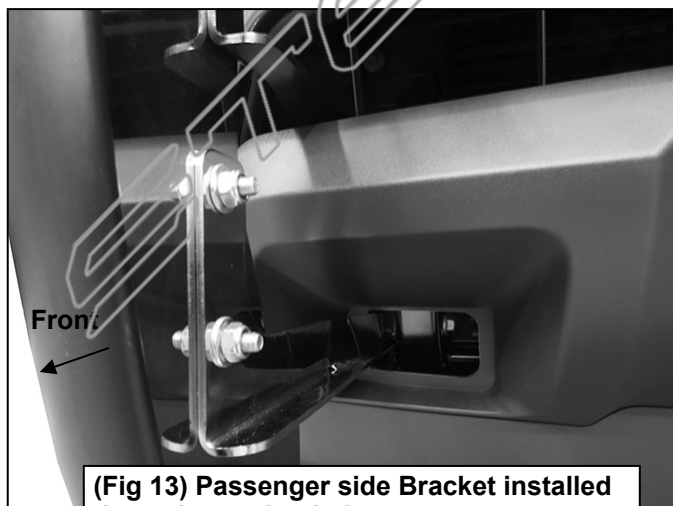

(Fig 13) Passenger side Bracket installed through opening in bumper cover

### Passenger Side Installation Pictured

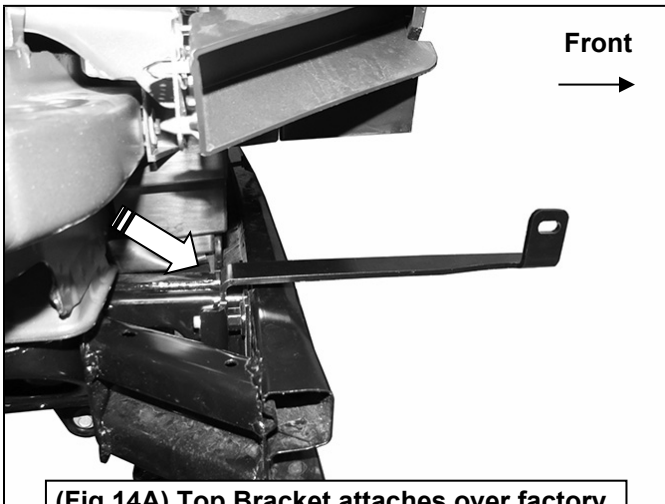

(Fig 14A) Top Bracket attaches over factory bolt (arrow). Air deflector and bumper removed for instructions purposes only

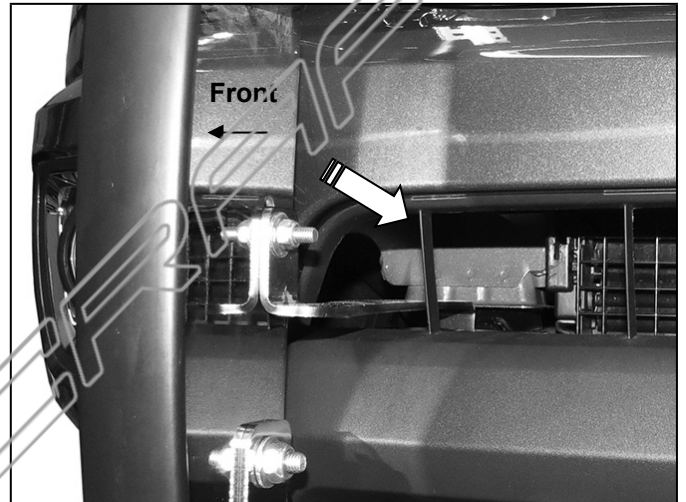

(Fig 14B) Insert Top Bracket through opening in bumper and hook over factory bolt on back of steel inner bumper

8mm x 30mm Hex Bolt  
(2) 8mm Flat Washers  
8mm Nylon Lock Nut

10mm Flat Washer  
10mm Nylon Lock Nut

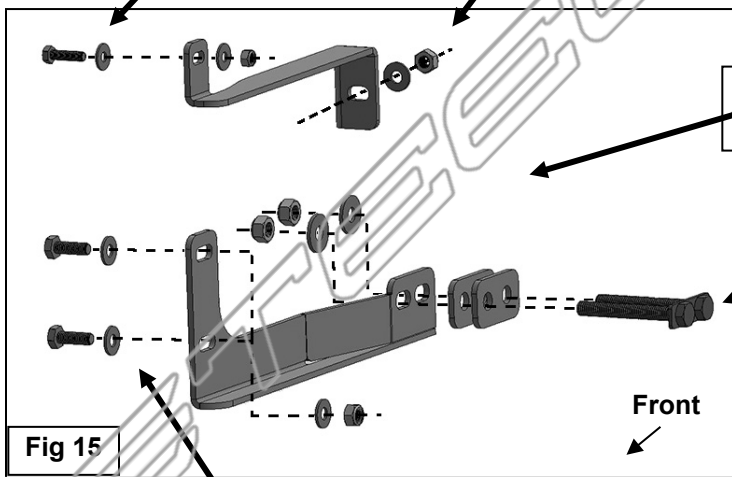

(2) 12mm Spacers (models without tow hooks only)

12mm Double Bolt Plate  
(2) 12mm Flat Washers  
(2) 12mm Nylon Lock Nuts

Fig 15

(2) 10mm x 30mm Hex Bolts  
(4) 10mm Flat Washers  
(2) 10mm Nylon Lock Nuts



Complete Installation