

INSTALLATION INSTRUCTIONS

**1PC REAR BUMPER TIRE CARRIER
07-18 JEEP WRANGLER JK**

**1PC REAR BUMPER TIRE CARRIER
07-18 JEEP WRANGLER JK**

PARTS LIST:

1	Swing Arm	2	Rubber Bump Stops
1	Tailgate Block Off Bracket	1	Cover Plate with stop
1	Tire Mounting Bracket	3	½"-20 Lug Nuts
1	Adj Base Bracket for Tire Mount	2	12-1.75mm x 70mm Hex Bolts
1	Upper 3rd Brake Light Bracket	4	12-1.75mm x 45mm Hex Bolts
1	Lower 3rd Brake Light Bracket	4	12mm Lock Washers
1	Swing Arm Pivot Axle Assembly	8	12mm x 24mm x 2.5mm Flat Washers
1	Dust Cap	2	12mm Nylon Lock Nuts
1	4mm Pan Head Screw	3	10-1.5mm x 40mm Hex Bolts
1	8mm Set Screw	4	10-1.5mm x 35mm Hex Bolts
1	Cotter Pin	14	10mm x 24mm x 2.2mm Flat Washers
1	Castle Nut	7	10-1.5mm Nylon Lock Nuts
1	Upper Spacer Washer (small)	4	8-1.25mm x 25mm Hex Bolts
1	Upper Bearing and Race	8	8mm x 24mm x 2mm Flat Washers
1	Lower Bearing and Race	4	8-1.25mm Nylon Lock Nuts
1	Lower Spacer Washer (large)	2	5mm x 20mm Hex Bolts
1	Lower Grease Seal	2	5mm x 15mm x 1.2mm Flat Washers
1	12mm Right Hand Thread Rod End	2	5mm Nylon Lock Nuts
1	12mm Right Hand Thread Jam Nut	1	4mm Allen Wrench
1	12mm Left Hand Thread Rod End	4	ST5.5 x 38mm Self Tapping Screw
1	12mm Left Hand Thread Jam Nut	4	6mm x 12mm x 1.6mm Flat Washers
1	Threaded Adjuster Sleeve	1	Grease Fitting

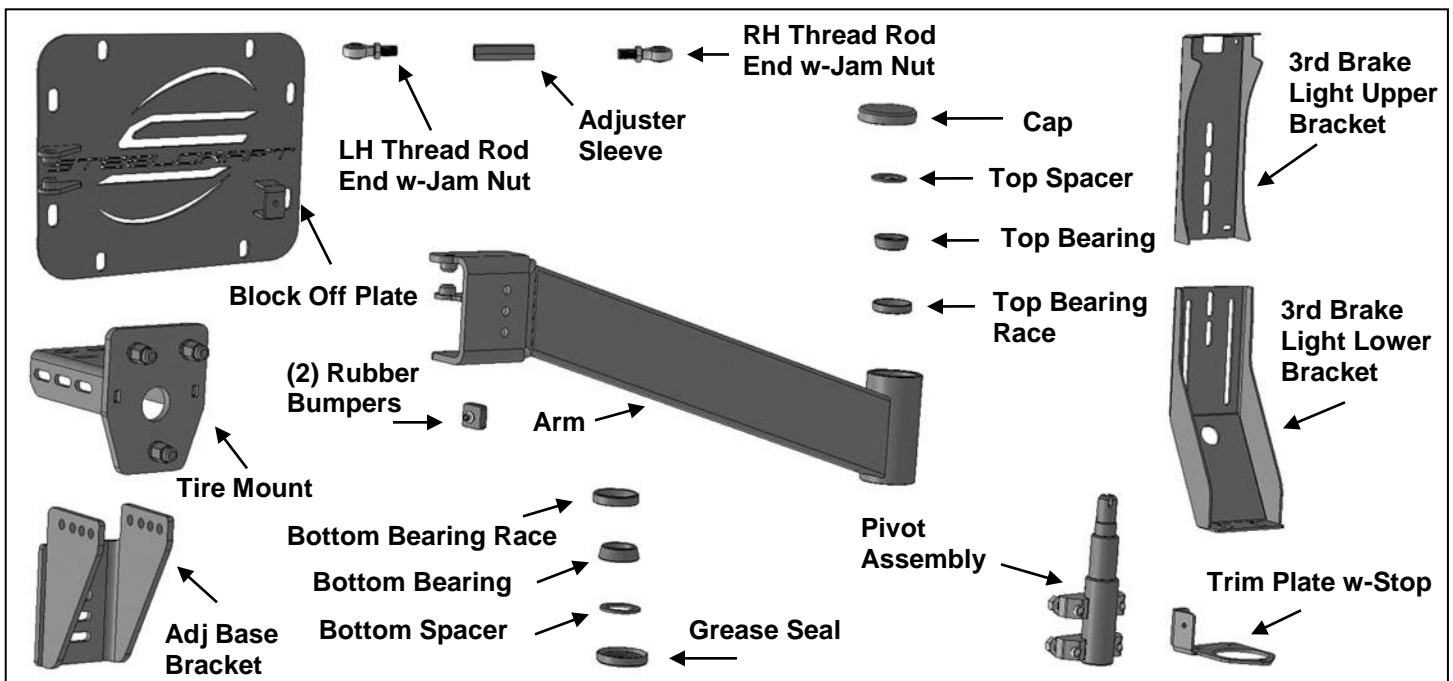

PROCEDURE:

- 1. REMOVE CONTENTS FROM BOX. VERIFY ALL PARTS ARE PRESENT. READ INSTRUCTIONS CAREFULLY BEFORE STARTING INSTALLATION.**
- Remove the spare tire, **(Figure 1)**. Next, remove the (4) screws attaching the 3rd brake light with plastic bracket to the spare tire mount. Unplug the light. Remove the tire mount, rubber grommet and the louver assembly from the rear door, **(Figures 2 & 3)**.
- Select the rear door Block Off Plate, **(Figure 4)**. Reuse the factory screws to attach the Block Off Plate to the door. Select (1) Rubber Bump Stop. Attach the Bump Stop to the mount on the Block Off Plate with (1) 5mm x 20mm Screw, (1) 5mm Flat Washer and (1) 5mm Nylon Lock Nut, **(Figure 4)**. Tighten hardware at this time.
- Next, remove the (3) screws and cover from the top-right side of the bumper, **(Figures 5 & 6)**. Select the Cover Plate with Bump Stop mount. Reuse the (3) Screws to attach the Cover Plate to the top of the bumper. Select (1) Rubber Bump Stop. Attach the Bump Stop to the mount on the Cover Plate with (1) 5mm x 20mm Screw, (1) 5mm Flat Washer and (1) 5mm Nylon Lock Nut, **(Figure 7)**. Fully Tighten Cover Plate and Bump Stop hardware only at this time.
- Select the Pivot Shaft Assembly, **(Figure 8)**. Attach the Pivot Shaft Assembly to the mounting flange on the back of the bumper with (4) 12-1.75mm x 45mm Hex Bolts, (4) 12mm Lock Washers and (4) 12mm Flat Washers, **(Figures 8 & 9)**. Fully tighten this hardware only at this time.
- Select the Tire Mount Arm. Turn Arm upside-down, **(Figure 10)**. Insert the Large Lower Bearing Race into the bearing housing on the Arm. **NOTE:** Bearing Race is not a press fit and may slide into position. Select the Large Lower Bearing. Apply a liberal amount of heavy grease, (waterproof wheel bearing grease preferred), to the Bearing. Insert the Bearing into the Bearing Race. Place the Large Bearing Spacer Washer over the Bearing. Press the Lower Bearing Seal into the Bearing housing until it is flush with the bearing housing, **(Figure 10)**.
- Turn Tire Mount Arm over, (right side up). Insert the Small Top Bearing Race into the bearing housing. Slide bearing housing on Arm over the Pivot Shaft on the Bumper, **(Figure 11)**. Repeat **Step 6** to insert the Small Top Bearing Race, Top Bearing and Top Spacer Washer into the top of the Arm. Attach the Arm assembly to the Pivot Shaft with the large Castellated (slotted) Hex Nut, **(Figure 11)**. Slowly tighten the Castle Nut to "seat" bearings in Races. Rotate Arm on Pivot Shaft open and closed several times to spread grease on Bearings. Tighten Castle Nut until there is little to no rocking in the Arm. **DO NOT OVERTIGHTEN.** Line up the slot in the Castle Nut with the slot in the end of the Pivot Shaft. Slide Cotter Pin down and into Slots in the Castle Nut and the Pivot Shaft. Center the Cotter Pin in the Bearing Housing so that it doesn't contact inside of bearing housing. Lock Cotter Pin in place with included Set Screw, **(Figures 11 & 12)**.
- Next, select the Right-Hand Thread 12mm Rod End and Right-Hand Thread 12mm Jam Nut, **(Figure 13)**. Thread the Jam Nut onto the Rod End. Carefully thread the Rod End with Nut into the Right-Hand Thread side of the Adjuster Sleeve. **VERY IMPORTANT:** The Adjuster Sleeve features right hand thread on one side and left-hand thread on the other. Select the Left-Hand Thread 12mm Rod End and Left-Hand Thread Jam Nut. Thread the Left-Hand Rod End and Nut into the adjuster sleeve approximately the same amount of turns as the right-hand thread. Both Rod Ends should be threaded into the Sleeve an equal amount, **(Figure 13)**.
- Attach one Rod End on the Adjustable Linkage Assembly to the mount in the top end of the Arm with (1) 12mm x 70mm Hex Bolt, (2) 12mm Flat Washers and (1) 12mm Nylon Lock Nut, **(Figure 14)**.
- Select the Spare Tire Base Bracket, **(Figure 15)**. **NOTE:** The Base Bracket features several mounting positions to adjust height for various tire sizes. Attach Base Bracket to Arm with the included (3) 10mm x 40mm hex Bolts, (6) 10mm Flat Washers and (3) 10mm Nylon Lock Nuts. Snug but do not fully tighten hardware at this time. **IMPORTANT:** Select mounting holes as far apart from each other as possible for additional support.
- Attach the remaining Rod End to the mount on the Block Off Plate with (1) 12mm x 70mm Hex Bolt, (2) 12mm Flat Washers and (1) 12mm Nylon Lock Nut, **(Figure 16)**. If Rod End cannot reach the mount on the Cover Plate, hold the loose Rod End in one hand to prevent it from turning, and turn the adjuster sleeve to lengthen or shorten the linkage assembly as needed, **(Figure 13)**. Once length is set, attach loose rod end to Cover Plate as previously instructed, **(Figure 16)**. **NOTE:** Do not tighten jam nuts on Rod Ends at this time

**1PC REAR BUMPER TIRE CARRIER
07-18 JEEP WRANGLER JK**

12. With linkage attached, **slowly** open the rear door. Adjust Linkage Assembly in or out until Tire Mount Arm is tight against Bump Stop on Cover Plate with rear door closed. Fully tighten all linkage hardware and Jam Nuts.
13. Next, select the Spare Tire Mounting Bracket, **(Figure 17)**. **NOTE:** The Mounting Bracket features several mounting positions to adjust for various tire widths and wheel combinations. Attach the Mounting Bracket to the top of the Base Bracket with (4) 10mm x 35mm Hex bolts, (8) 10mm Flat Washers and (4) 10mm Nylon Lock Nuts, **(Figures 17 & 18)**. **IMPORTANT:** Select mounting holes as far apart from each other as possible for additional support.
14. With assistance, hold the spare tire up in position and attach to the Mounting Bracket with the included (3) Lug Nuts. Check for clearance between bumper and tire and adjust height, (Base Bracket location), as necessary. Next, check clearance between tire and Arm. Tire should be tight against arm for stability, **(Figure 19)**. Adjust in-out location of Spare Tire Mounting Bracket as necessary.
15. Once properly adjusted, fully tighten Spare Tire Base and Mounting Brackets.
16. Select the Base Bracket for the 3rd Brake Light, **(Figure 20)**. Attach the Base Bracket to the back (2) mounting holes in the top of the Spare Tire Mounting Bracket with (2) 8mm x 25mm Hex Bolts, (4) 8mm Flat Washers and (2) 8mm Nylon Lock Nuts. Insert the wire harness up and through the hole in the bracket. Next, attach the upper 3rd Brake Light Mounting Bracket to the inside of the Base Bracket with (2) 8mm x 25mm Hex Bolts, (4) 8mm Flat Washers and (2) 8mm nylon Lock Nuts. Plug the wiring harness into the brake light. Attach the plastic 3rd brake light assembly to the inside of the Mounting Bracket with the included (4) Screws and (4) Flat Washers, **(Figure 21)**. Adjust the Mounting Bracket up or down as needed to clear the top of the tire and fully tighten all hardware. **IMPORTANT:** Do not overtighten Screws into plastic 3rd brake light housing.
17. **Slowly** open the rear door with spare tire attached. Make any final adjustments and fully tighten all hardware.
18. Install included Threaded Grease Fitting into hole in side of Bearing housing, **(Figure 22)**. Slide cap over top of Bearing Housing and lock in place with 4mm Pan Head Screw. **NOTE:** Apply thin layer of silicone to top cap if used in extreme conditions.
19. Do periodic inspections to the installation to make sure that all hardware is secure, tight and properly adjusted. Always remove spare tire before servicing bearing assembly.

To protect your investment, wax this product after installing. Regular waxing is recommended to add a protective layer over the finish. Do not use any type of polish or wax that may contain abrasives that could damage the finish. Mild soap may be used to clean the Tire Mount.



(Fig 1) Unplug and remove 3rd brake light assembly from factory spare tire mount

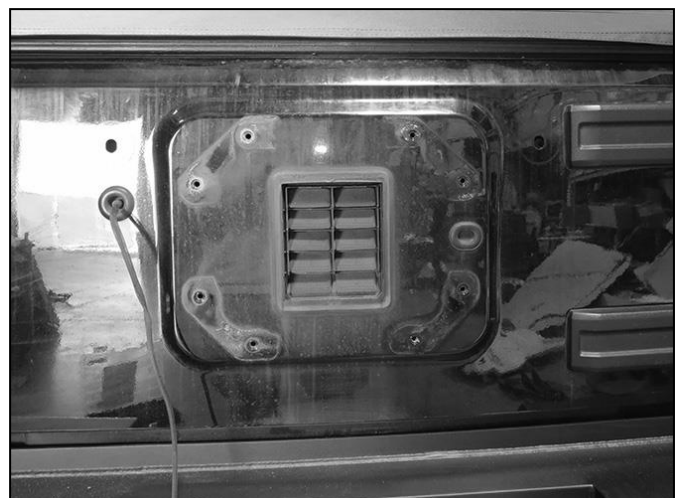

(Fig 2) Remove factory spare tire mount assembly

**1PC REAR BUMPER TIRE CARRIER
07-18 JEEP WRANGLER JK**

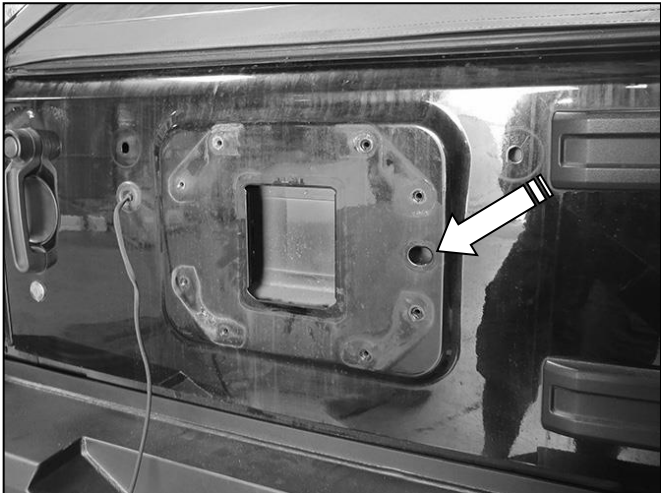

(Fig 3) Remove vent and rubber grommet (arrow)

- Bump Stop**
- 5mm x 20mm Button Head Screw**
- 5mm Flat Washer**
- 5mm Nylon Lock Nut**

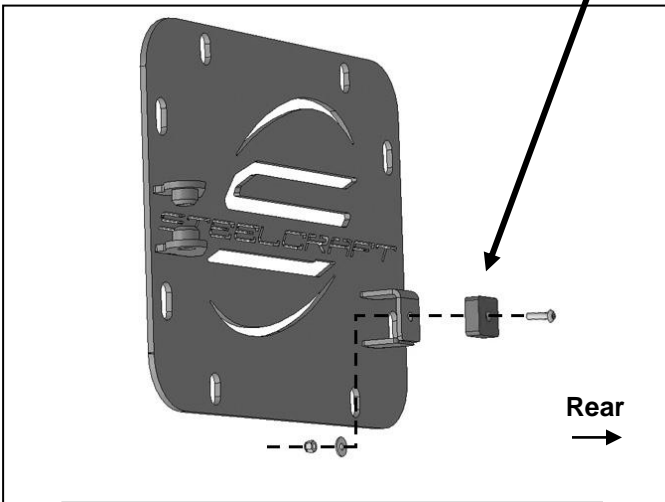

(Fig 4) Reuse factory hex bolts to attach Block Off Cover Plate to rear door. Attach Bump Stop to mount on Cover



(Fig 5) Remove cover plate

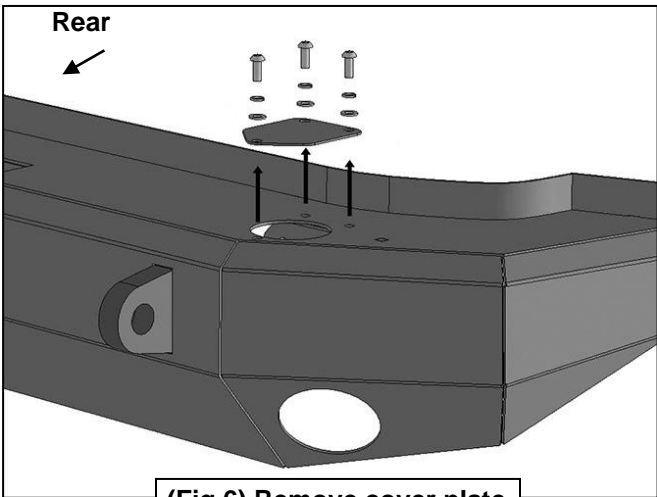

(Fig 6) Remove cover plate

**1PC REAR BUMPER TIRE CARRIER
07-18 JEEP WRANGLER JK**

Reuse hardware from Fig. 6

Bump Stop
5mm x 20mm Button Head Screw
5mm Flat Washer
5mm Nylon Lock Nut

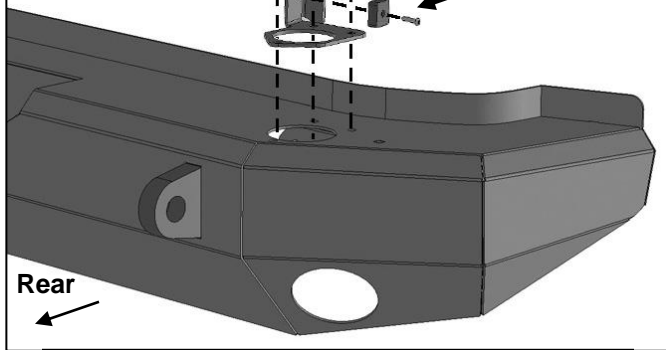

(Fig 7) Reuse hardware to attach Cover Plate with Stop. Attach Bump Stop to Cover Plate

(4) 12mm x 45mm Hex Bolts
(4) 12mm Lock Washers
(4) 12mm Flat Washers

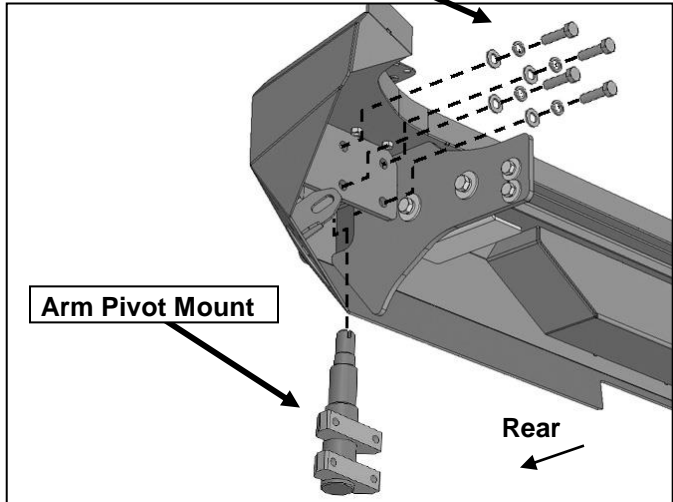

(Fig 8) Attach Arm Pivot Mount to mounting plate on back of Bumper (illustrated from below)

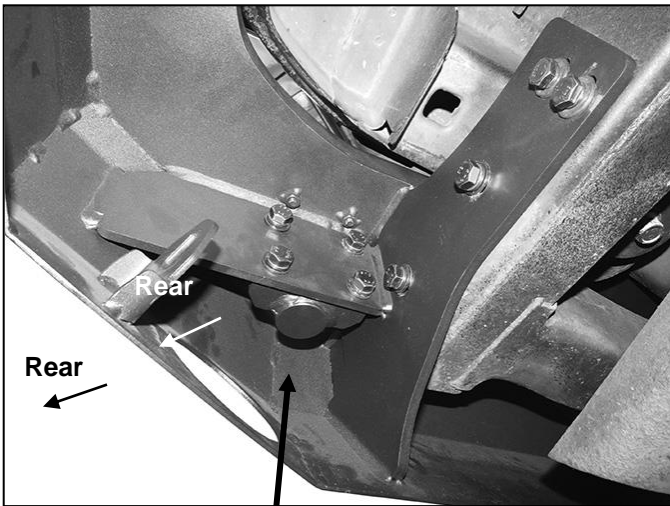

(Fig 9) Attach Arm Pivot Mount to mounting plate on back of Bumper (pictured from below passenger/right side)

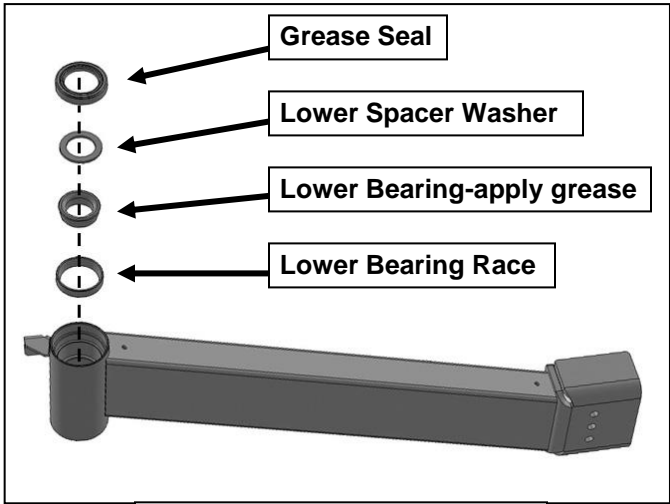

(Fig 10) Turn Arm over and install Lower Bearing and Seal

1PC REAR BUMPER TIRE CARRIER
07-18 JEEP WRANGLER JK

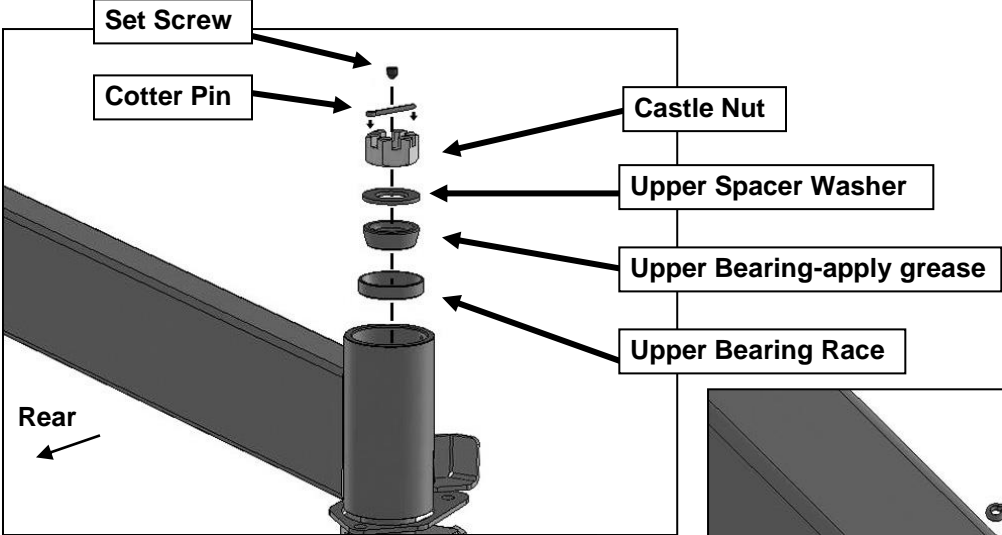

(Fig 11) Turn Arm over and slide onto Pivot Mount. Insert Top Bearing Race, Bearing and Spacer Washer

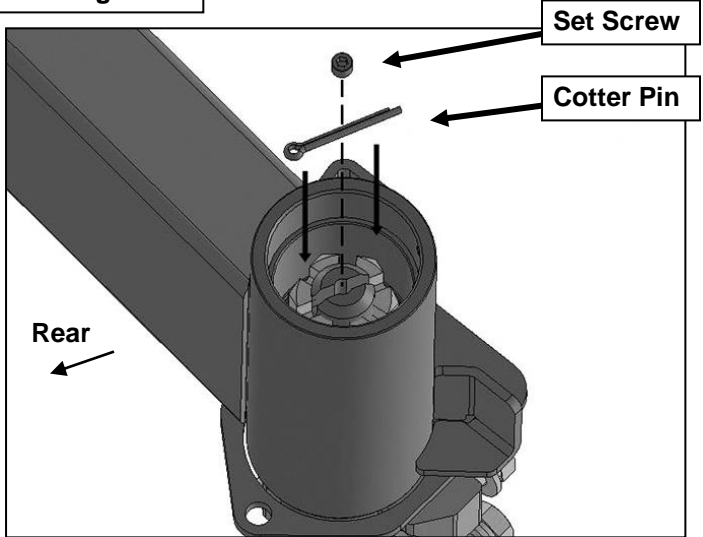

(Fig 12) Tighten Castle Nut to remove play in Arm. Cycle Arm in and out to spread grease in Bearings. Line up slot in Nut with slot in end of Pivot. Slide Cotter Pin into slot and secure with Set Screw.

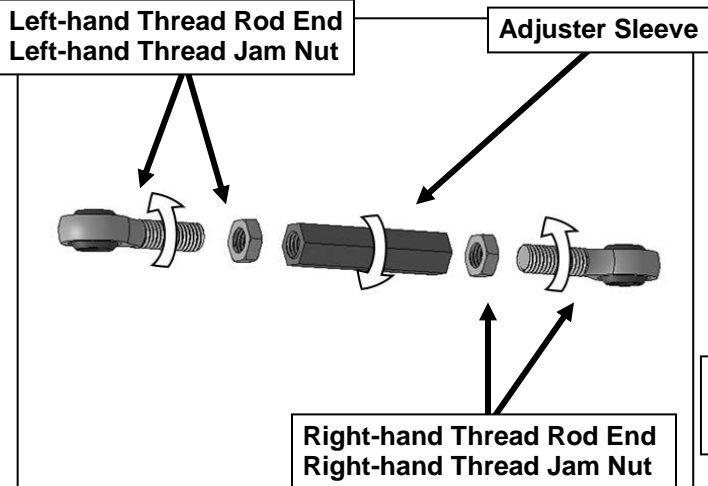

(Fig 13) Carefully thread the Left-Hand Thread Jam Nut onto Left Hand Thread Rod End. Insert assembled Rod End into left-hand threaded side of Adjuster Sleeve. Repeat to install the Right-Hand Thread Rod End assembly into the Adjuster Sleeve. NOTE: Thread both Rod Ends into Adjuster Sleeve an equal amount. IMPORTANT: Assemble by hand only, make sure threads are in correct direction before tightening. Do not fully tighten the Jam Nuts against the Adjuster Sleeve until all adjustments have been made

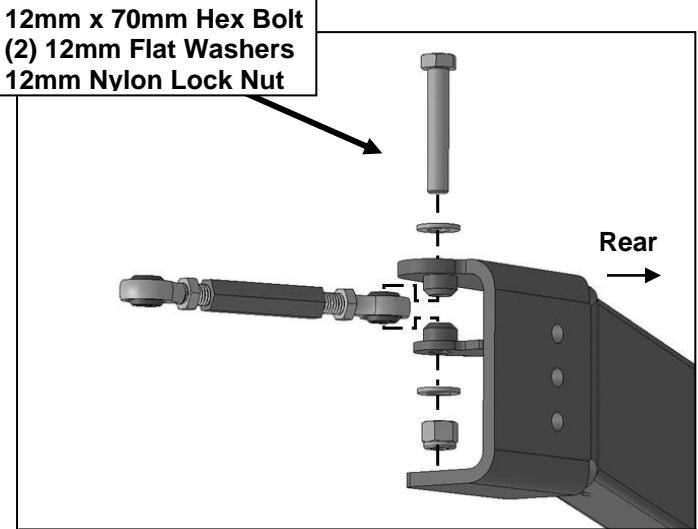

(Fig 14) Attach Red End Adjuster Assembly to Arm

**1PC REAR BUMPER TIRE CARRIER
07-18 JEEP WRANGLER JK**

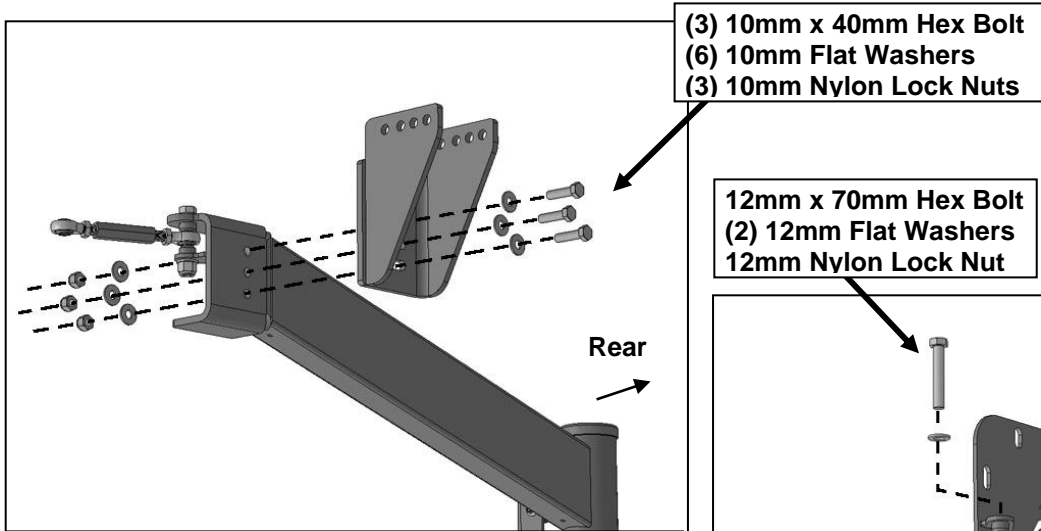

(Fig 15) Attach Base Bracket for Tire Mount to Arm

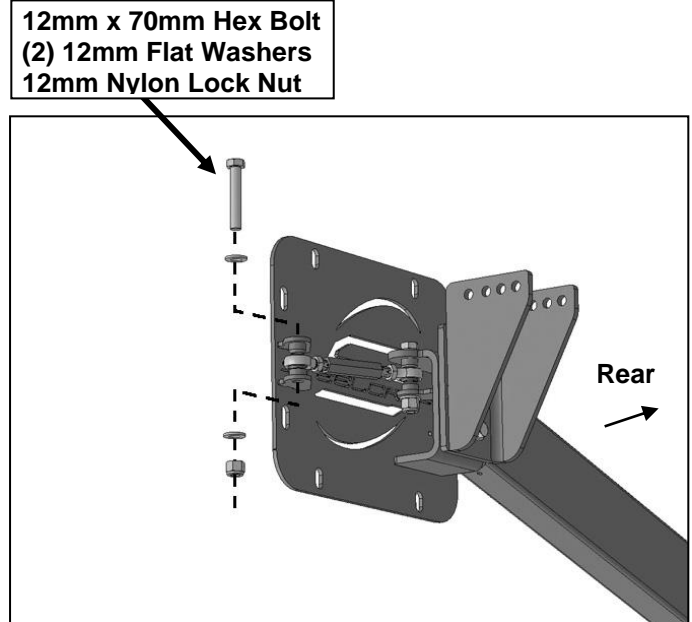

(Fig 16) Attach remaining end of Red End Adjuster Assembly to mounting tabs on the Block Off Plate

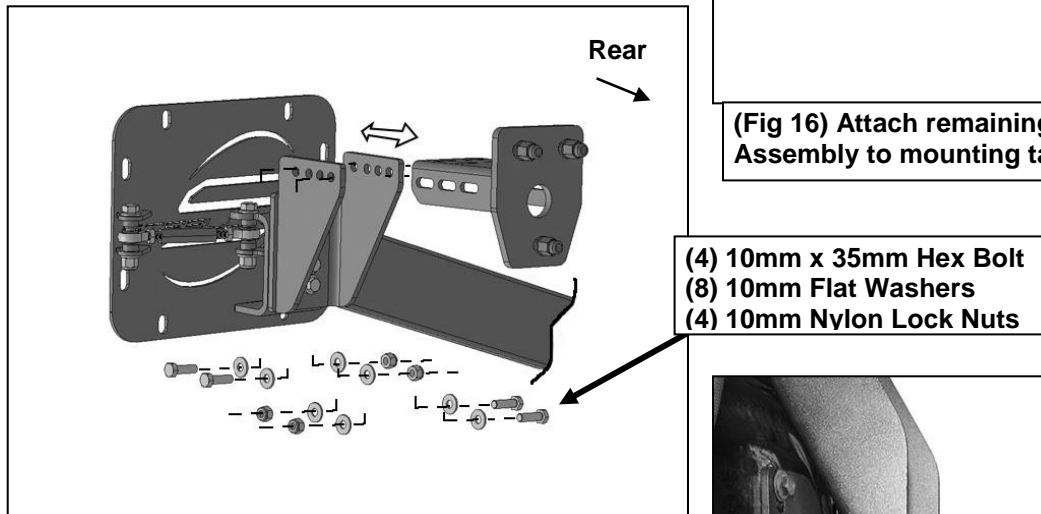

(Fig 17) Attach Tire Mount to Base Bracket

Attach Tire Mount to Base. Select mounting holes as far apart as possible for support. Check fit of tire assembly and adjust tire mounting brackets in or out, up or down as required. Adjust Brackets so that tire is in contact with Arm (Fig 19)

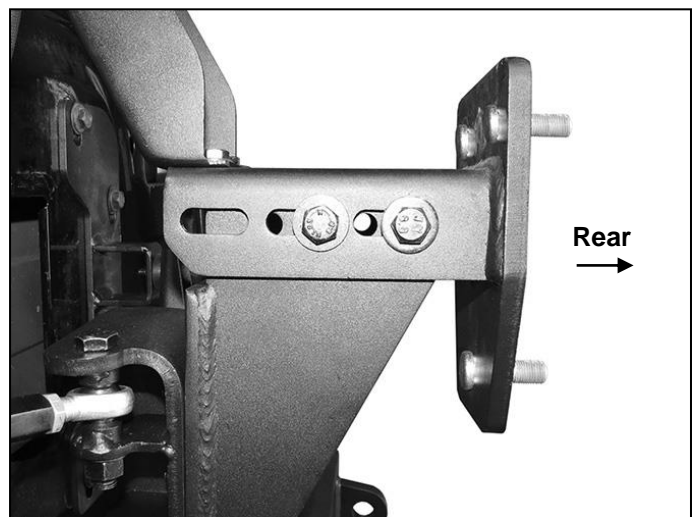

(Fig 18) Attach Tire Mount to Base Bracket

**1PC REAR BUMPER TIRE CARRIER
07-18 JEEP WRANGLER JK**



(Fig 19) Adjust Brackets so that tire is in contact with Arm. Temporarily remove spare tire

- (2) 8mm x 25mm Hex Bolt
- (4) 8mm Flat Washers
- (2) 8mm Nylon Lock Nuts

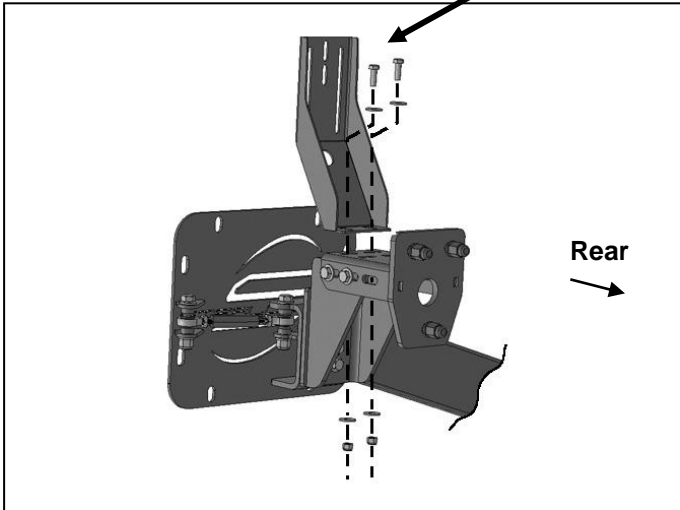

(Fig 20) Attach Base Bracket for factory 3rd brake light assembly to top of Tire Mount. Run wire for 3rd brake light through hole in Bracket

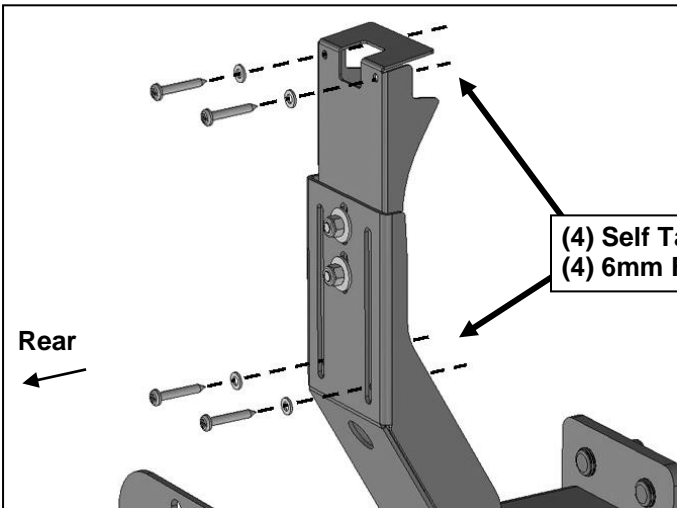

- (4) Self Tapping Screws
- (4) 6mm Flat Washers

(Fig 21) Attach Top Bracket to Base Bracket. Adjust height to clear spare tire. Plug in light and attach factory 3rd brake light assembly to Bracket

- Top Cap
- 4mm Pan Head Screw

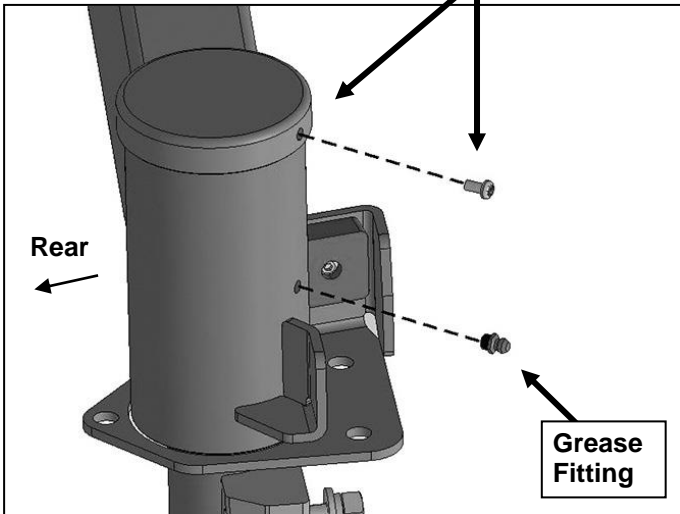

- Grease Fitting

(Fig 22) Once all adjustments have been made and all hardware tightened, install Grease Fitting and Cap over Top Bearings



Complete Installation