

FLOWMASTER™

FORCE II™ SYSTEM #17102 1985-87 BUICK GRAND NATIONAL

2/13/03

Removal:

- 1) Raise vehicle and support securely with jackstands.
- 2) Cut off muffler inlet pipes close to the muffler case. The bottom pipe on each side is the inlet pipe.
- 3) Remove the two (2) 2¼ horseshoe clamps on the y-pipe end of the muffler inlet pipes (just in front of the rear axle).
- 4) Remove pipes, at the slip-fit connection, from stock Y-pipe. A torch may be used to heat the connections to ease removal. **PLEASE USE EXTREME CAUTION!** After the pipes have been separated, use sandpaper or a wire brush to "clean up" the Y-pipe outlets to provide proper sealing when **FLOWMASTER** System is installed.
- 5) Support the existing muffler with jackstands or a sturdy box.
- 6) Use a 13mm wrench to remove the two (2) bolts that connect the stock muffler/tailpipe hangers to the tailpipes on each side of the muffler.
- 7) Carefully lower the system and remove from underneath the car.

Installation:

- 1) Slip the pipe #16011 onto the right side of the stock Y-pipe and install a 2¼" clamp provided in the kit. (Do not tighten).
- 2) Slip the pipe #16012 onto the left side of the stock y-pipe and install a 2¼" clamp provided in the kit. (Do not tighten).
- 3) Raise FLOWMASTER muffler #42486 into the stock location behind the rear axle and support it with hangers.
- 4) Slip pipe #16012 (on the left side) and #16011 (on the right side) into the inlets on top of the muffler. Install 2¼" clamps. (Do not tighten).

- 5) Insert tailpipes (2) #16010 into the muffler outlets on the sides of the muffler. Install the provided 2¼" clamps. (Do not tighten)
- 6) Adjust the positioning of all pipes to attain proper fit and alignment. NOTE: Maintain a minimum of ½" clearance between **FLOWMASTER** System and the drivetrain, all chassis components, brake lines and fuel lines.
- 7) Be sure all clamps and hangers will not make contact with chassis components, hoses or wires during suspension travel. Tighten all clamps securely.
- 8) Chrome tips may be installed, depending on owner preference.

NOTE: FLOWMASTER RECOMMENDS WELDING ALL SLIP-FIT CONNECTIONS.

Packing list

| <u>Qty</u> | <u>Description</u> | <u>Part #</u> |
|------------|--------------------|---------------|
| 1 | Muffler | #42486 |
| 2 | Tailpipes | #16010 |
| 1 | Inlet Pipe,Left | #16012 |
| 1 | Inlet Pipe,Right | #16011 |
| 1 | Parts kit | #PK102 |
| 6 | 2¼" Clamp | #MC214S |

FLOWMASTER FORCE II SYSTEM #17102
1985-1987 BUICK GRAND NATIONAL

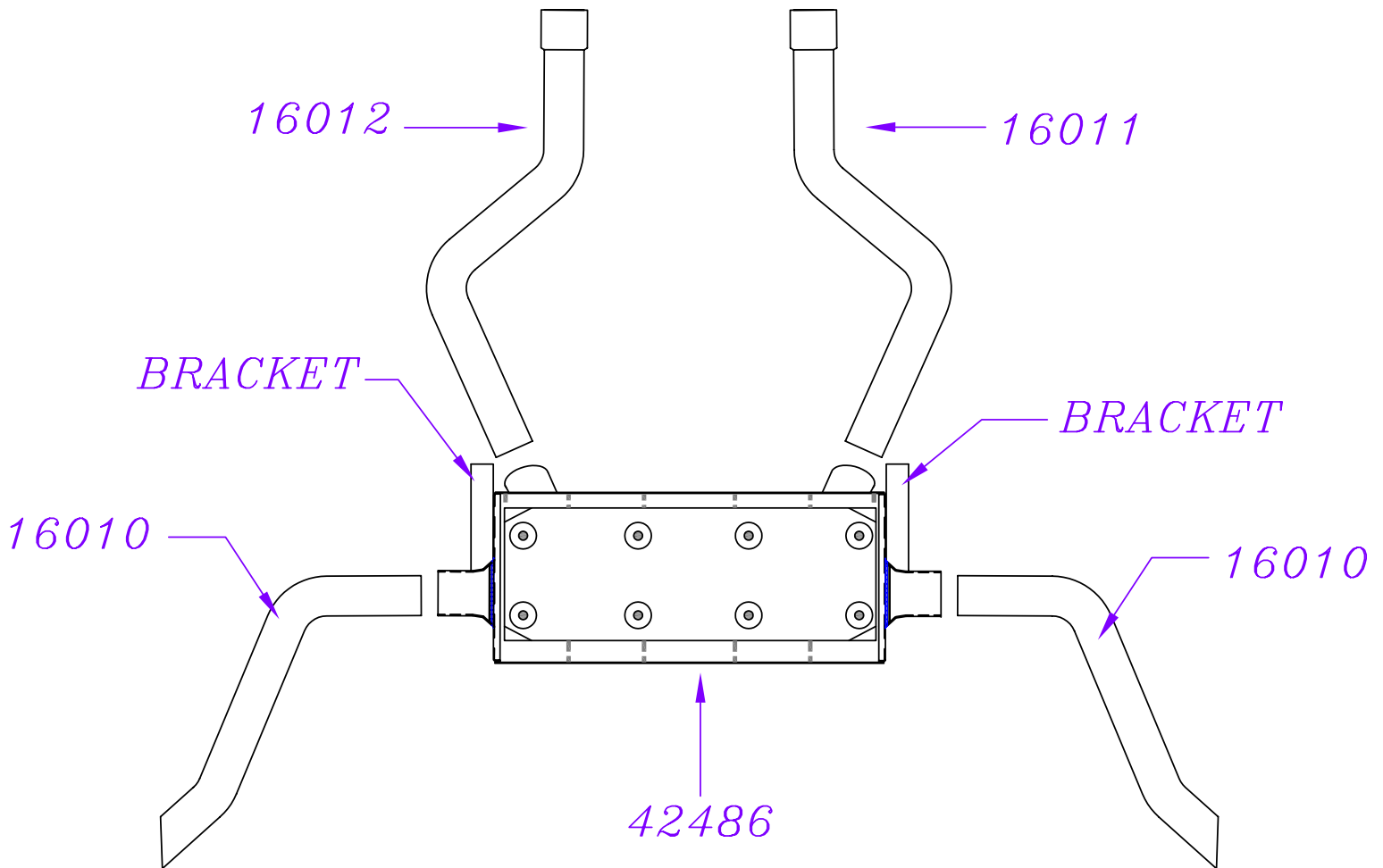

REAR OF CAR (TOP VIEW)