

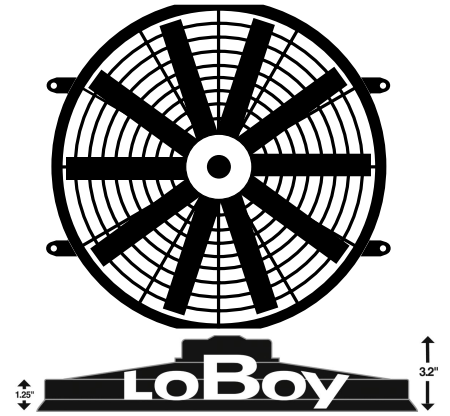

LoBoy Electric Fan

118 Puller / 119 Pusher

Installation Instructions



Puller Mode Mounting Instructions (see diagram "A")

1. Attach the mounting tabs to the electric fan. See diagram "A".
2. Position the electric fan against the radiator, and mark mounting hole locations.
3. Pass a small Phillips screwdriver through the marked holes, carefully spreading the fins to allow easy passage for the nylon bolts. Fit the bolts to the mounting tabs, and pass the bolts through the shroud holes in the radiator.
4. Push on the speed nuts until they are snug.
5. Cut off the end of the mounting bolts, leaving 1/4" remaining.

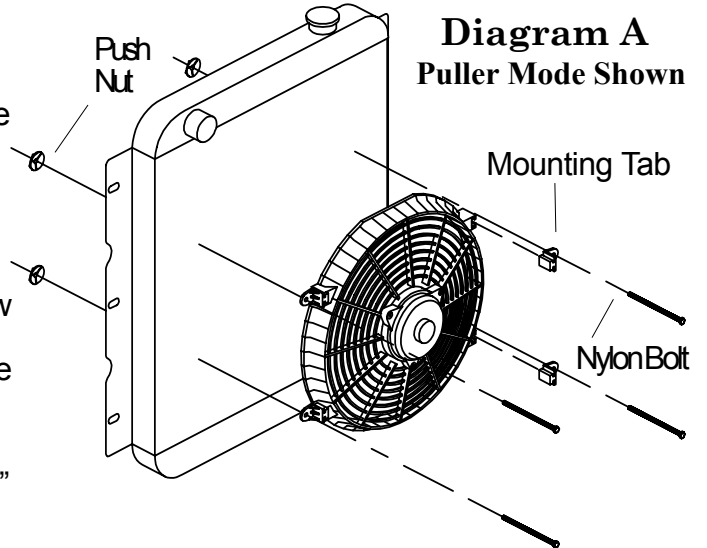

Diagram A
Puller Mode Shown

Pusher Mode Through Core Mounting Instructions

Follow the instructions above, except mount fan on the front side of the radiator

Note: Some vehicles have a/c condensers or transmission coolers mounted in front of the radiator. Modifications may be necessary to accommodate the fan.

Wiring Instructions

Important: Pusher fans:
Black wire is positive (+)
Blue / Red wire is negative (-)

Important: Puller fans:
Blue / Red wire is positive (+)
Black wire is negative (-)

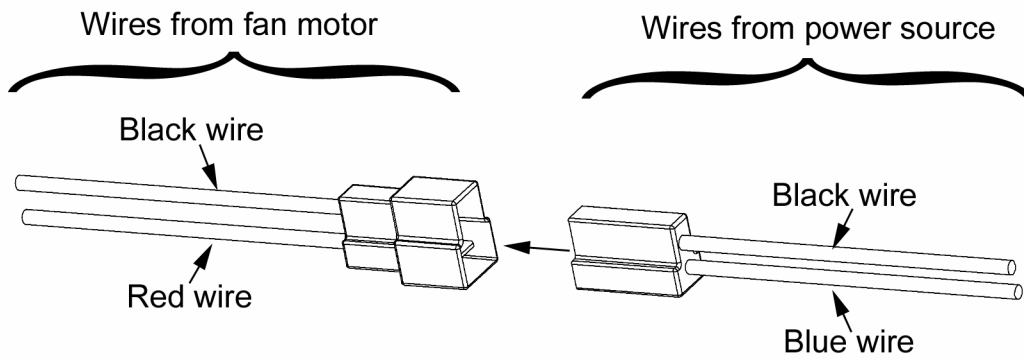

NOTE: Accessories such as relay kits and temperature control kits are available for this product! See www.flex-a-lite.com for details.

Important: Disconnect the battery prior to wiring this product.

Direct Connect: (Fan will operate when the ignition is "on")

1. Attach the positive fan motor wire to a 12 V positive ignition controlled source (example - fuse box). Use the inline fuse holder and fuse provided for each fan.
2. Attach the negative fan motor wire to a suitable ground. Note: Connect directly to battery negative terminal if possible.
3. Plug the mating connector from the power source into the motor wire connector, then reconnect the battery.

The Flex-a-lite Limited Warranty

Flex-a-lite Consolidated, 7213-45th St. Ct. E., Fife, WA 98424, Telephone No. 253-922-2700, warrants to the original purchasing user, that all Flex-a-lite products to be free of defects in material and workmanship for a period of 365 days (1 year) from date of purchase. Flex-a-lite products failing within 365 days (1 year) from date of purchase may be returned to the factory through the point of purchase, transportation charges prepaid. If, on inspection, cause of failure is determined to be defective material or workmanship and not by misuse, accidental or improper installation, Flex-a-lite will replace the fan free of charge, transportation prepaid. **Flex-a-lite will not be liable for incidental, progressive or consequential damages.** Some states do not allow the exclusion or limitation of incidental or consequential damages, so the above limitation or exclusion may not apply to you. This warranty gives you specific legal rights and you may have other rights, which vary from state to state. The Flex-a-lite warranty is in compliance with the Magnuson-Moss Warranty Act of 1975.