



A Holley Performance Brand

TIME DELAY BOX P/N 15838NOS

A5163-SNOS

INTRODUCTION:

This TIME DELAY BOX is designed to allow you to activate (time delay) or deactivate (turn off) a nitrous system based upon the time constants selected on the box. Time range of time available is adjustable from 0 to 9.9 seconds in .1 second increments.

TYPICAL WIRING SCHEMATICS:

SINGLE STAGE DELAY (WITHOUT RELAY)

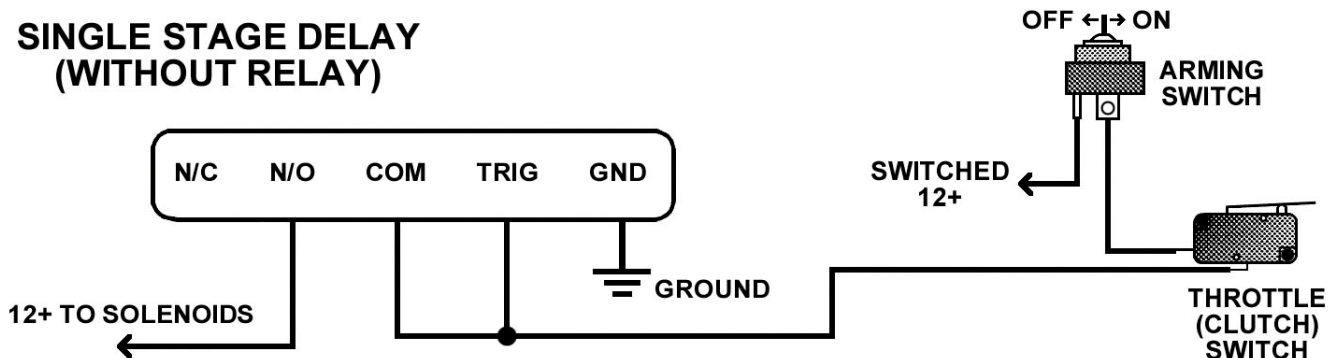

SINGLE STAGE DELAY (WITH RELAY)

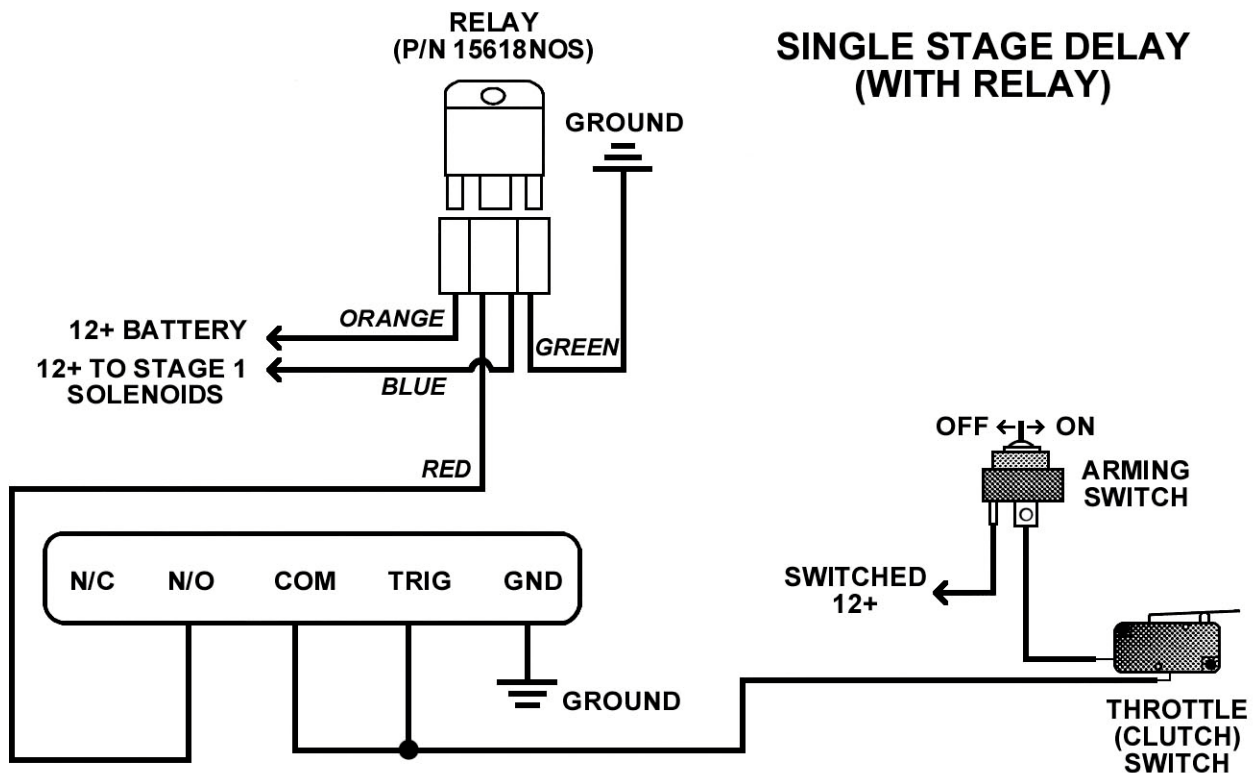

SINGLE STAGE DELAY (WITH TRANS BRAKE)

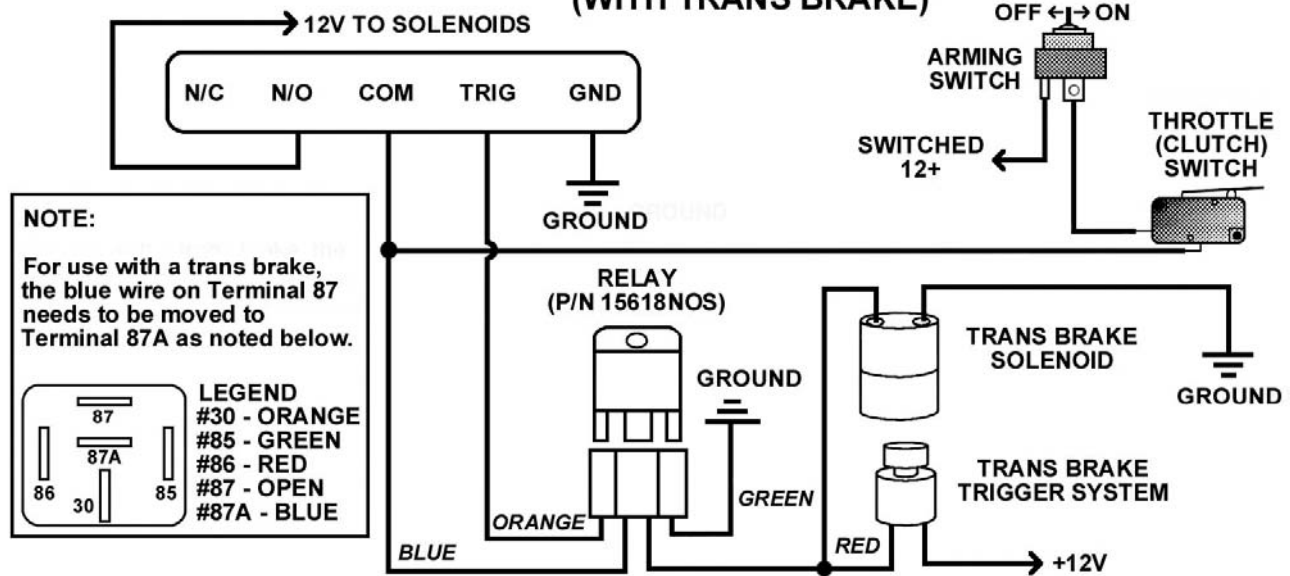

TWO STAGE DELAY (WITH RELAY)

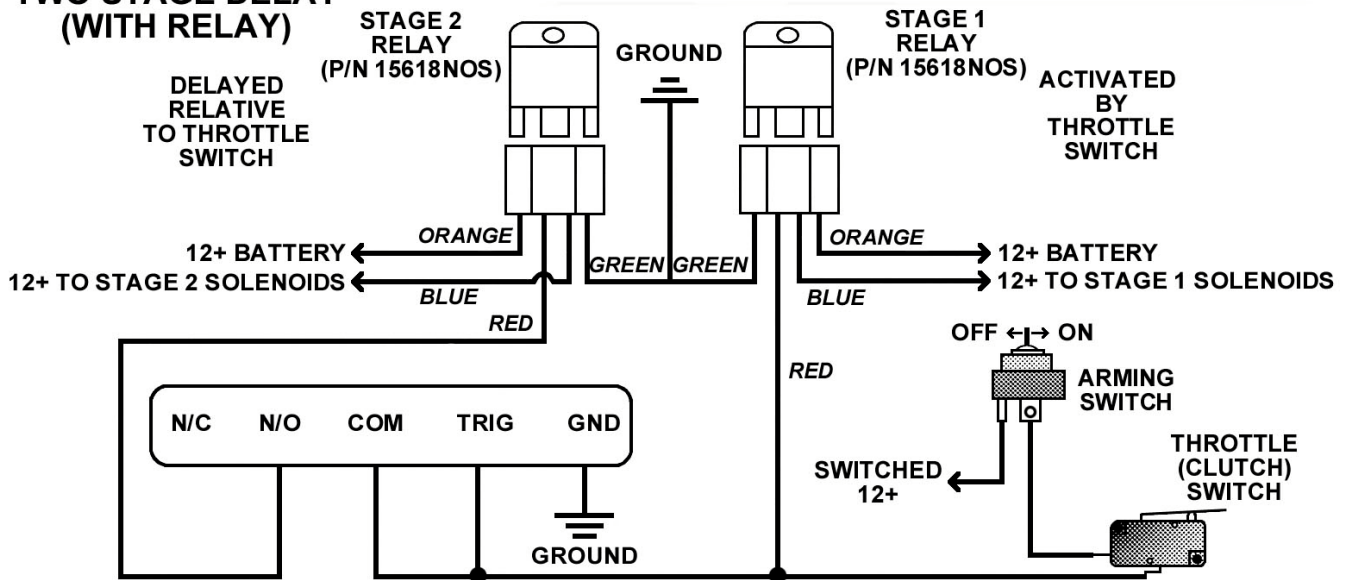

INSTALLATION TIPS:

If using an NOS RPM switch (P/N 15879NOS), connect the yellow wire from the RPM switch to the green wire from the relay that you desire to trigger.

Components used in this delay box are designed to handle a current load of up to 40 amps. If you intend to wire a system without using relays, make sure the other electrical components you use are capable of handling the current loads of your system.

If using a pushbutton to activate the delay box, connect it in place of the throttle (clutch) switch shown.

NOS Technical Support

Phone: 1-866-GOHOLLEY

Fax: 1-270-781-9772

For online help, please refer to the Tech Service section of our website: www.holley.com