

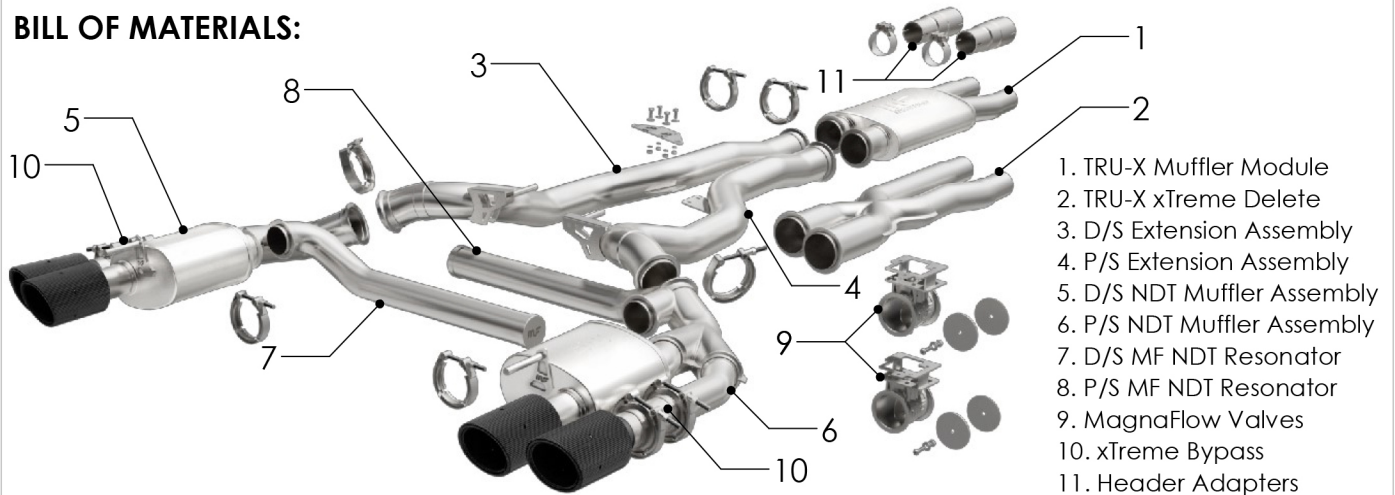

2019 FORD MUSTANG GT 5.0L | PART NO. 19535

BILL OF MATERIALS:



HARDWARE KIT:

- 1.[6] 3.00" V-Clamp
- 2.[4] 2.50" V-Clamp
- 3.[1] MF Bracket
- 4.[6] M6 Bolt
- 5.[6] M6 Nut
- 6.[6] M6 Lock Washer
- 7.[6] M6 Flat Washer
- 8.[2] xTreme Bypass Block-Off w/ Gaskets
- 9.[2] Header Adapter Pipes
- 10.[2] 2.50" Torca Clamps