

140-15912-D | Triumph TR4, TR250, TR6 | Wilwood Front Brake Kit

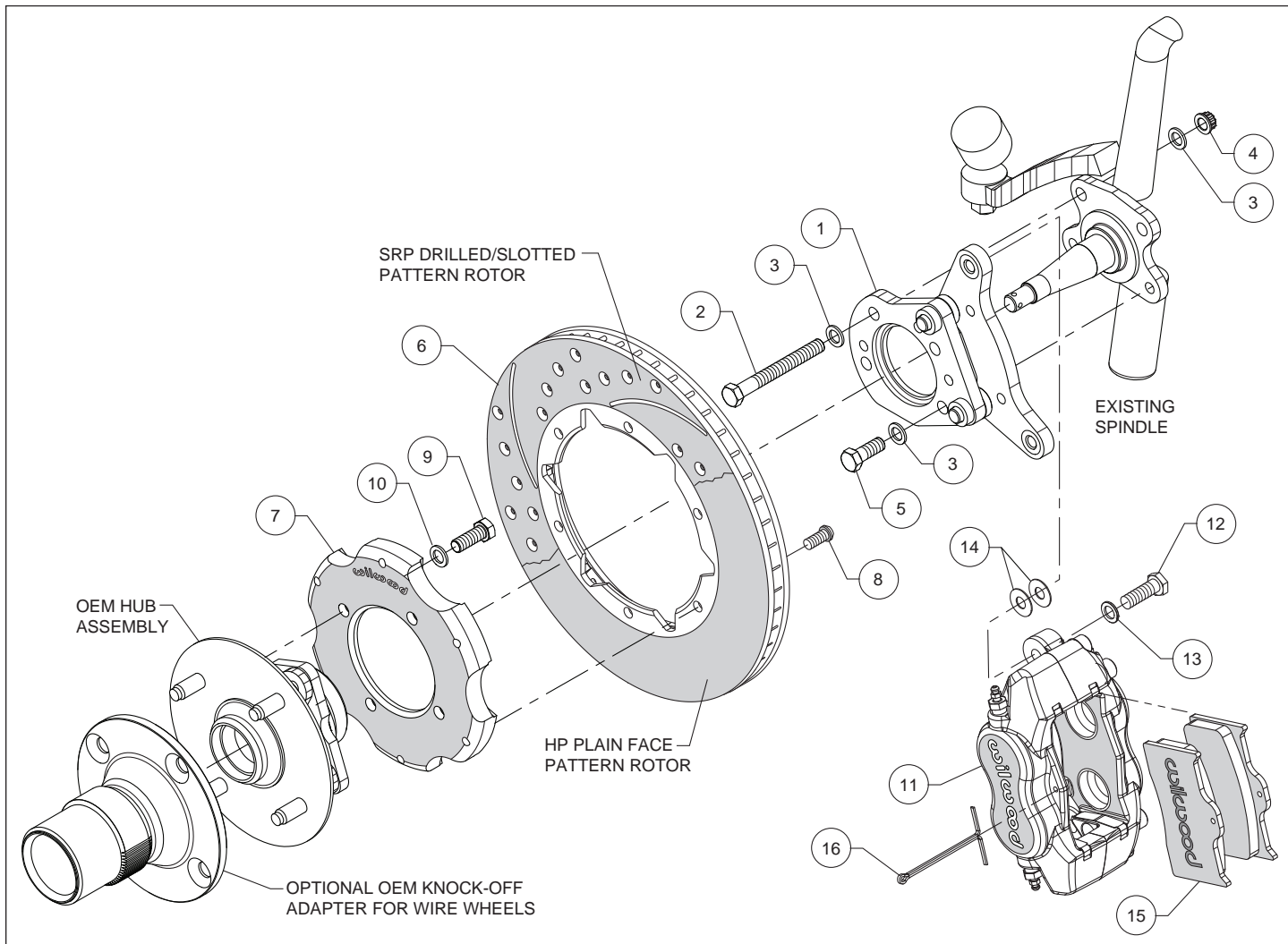

Parts List

<u>ITEM NO.</u>	<u>PART NO.</u>	<u>DESCRIPTION</u>	<u>QTY</u>
1	249-15915/16	Bracket, Caliper Mounting (pair, one each, left and right)	1
2	230-15914	Bolt, 3/8-24 x 3.25 Long, Hex Head	4
3	240-10190	Washer, .391 I.D. x .625 O.D. x .063 Thick	12
4	230-9183	Nut, 3/8-24, Self-Locking, 12 Point	4
5	230-10024	Bolt, 3/8-24 x 1.00 Long, Hex Head	4
6	160-7099/7100-BK	Rotor, Drilled and Slotted (pair, one each, left and right)	2
7	170-15920	Hat, 4 x 4.00, .725 Offset, 6 x 6.25 Bolt Circle	2
8	230-11934	Bolt, 5/16-18 x .75 Long, Torx Button Head	12
9	230-10024	Bolt, 3/8-24 x 1.00 Long, Hex Head	4
10	240-10190	Washer, .391 I.D. x .625 O.D. x .063 Thick	4
11	120-13842-BK	Caliper, Forged Dynalite, Black	2
12	230-0228	Bolt, 3/8-24 x 1.25 Long, Hex Head	4
13	240-10190	Washer, .391 I.D. x .625 O.D. x .063 Thick	4
14	240-1159	Shim, .035 Thick	16
15	150-8850K	Pad, BP-10 Compound, Axle Set	1
16	180-0055S	Pin, Cotter	2
17	220-15921	Braided Stainless Steel Flexline Kit (not shown)	1

NOTES:

Part Number 230-15913 Bolt Kit, bracket to spindle, includes part numbers 230-9183, 230-10024, 230-15914 and 240-10190

Part Number 230-12121 Bolt Kit, hat to rotor, includes part number 230-11934

Part Number 230-12078 Bolt Kit, hat to hub, includes part numbers 230-10024 and 240-10190

Part Number 230-0204 Bolt Kit, caliper to bracket, includes part numbers 230-0228, 240-10190 and 240-1159