

Exploded Assembly Diagram

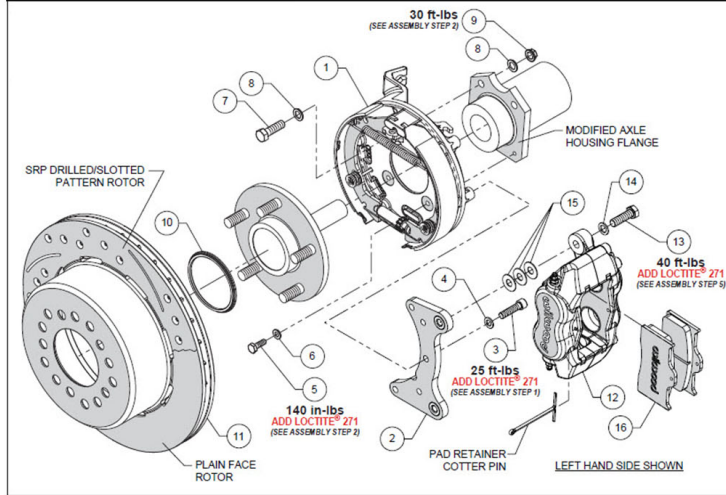

Parts List

ITEM NO.	PART NO.	DESCRIPTION	QTY
1	249-17122/23	Backing Plate Assembly, .642" Offset (one each, right and left)	2
2	249-16225/26	Bracket, Caliper Mounting (one each, right and left)	2
3	230-13690	Bolt, 5/16-24 x 1.25" Long, Socket Head	6
4	240-10191	Washer, .328" I.D. x .562" O.D. x .063" Thick	6
5	230-17154	Bolt, M6-1.00 x 20mm Long, Hex Head	4
6	240-11240	Washer, .265" I.D. x .500" O.D. x .063" Thick	4
7	230-10025	Bolt, 3/8-24 x 1.25" Long, Hex Head	4
8	240-10190	Washer, .391" I.D. x .625" O.D. x .063" Thick	8
9	230-16550	Nut, 3/8-24, Self Locking	4
10	300-11532	Adapter, Rotor Registration, 2.78" Diameter	2
11	160-9986	Rotor, ULHP, .81" Thick x 12.19" Diameter	2
11A	160-9814/15-BK	Rotor, Black, SRP Drilled and Slotted (one each, right and left)	2
12	120-13839-BK	Caliper, Forged DynaLite, Black	2
12A	120-13839-RD	Caliper, Forged DynaLite, Red	2
13	230-10025	Bolt, 3/8-24 x 1.25" Long, Hex Head	4
14	240-10190	Washer, .391" I.D. x .625" O.D. x .063" Thick	4
15	240-1159	Shim, .035" Thick	16
16	150-8850K	Pad, BP-10 Compound, Axle Set	1

NOTES:

Part Number 230-11861 Caliper Mounting Bolt Kit, includes part numbers 230-10025, 240-1159, and 240-10190

Part Number 230-16331 Bracket Mounting Bolt Kit, includes part numbers 230-13690 and 240-10191

Part Number 230-17191 Backing Plate Bolt Kit, includes part numbers 230-10025, 230-16550, 230-17154, 240-10190, and 240-11240

Item 11A is an optional item and included in the "-D" drilled rotor kits.

Add "-D" to end of part number when ordering.

Item 12A is an optional item and included in the "-R" red caliper kits.

Add "-R" to end of part number when ordering.