

## **Installation Instructions for 30540 2-1/2" Header Dual Kit w/o Mufflers**

**Application: 67-'81 Camaro V8, '75 Buick Apollo V8, '75-'79 Buick Skylark V8, '67-'81 Firebird V8, '62-'79 Nova/Chevy II V8, '73-'79 Omega V8, '72-'79 Phoenix & Ventura V8, all with standard headers and with 3" collectors at the headers.**

NOTE: The headers, mufflers and catalytic converters are not supplied with this exhaust system. This system is not legal for on-road use on vehicles that originally were equipped with a catalytic converter.

### **Kit Includes:**

- |                          |                                  |
|--------------------------|----------------------------------|
| 4) ST4 hangers           | 1) Left Collector Pipe           |
| 4) Snapper Grommets      | 1) Right Collector Pipe          |
| 4) 5/16" x 1" Lag Screws | 2) #MP48005 3" Collector Gaskets |
| 8) 2-1/2" Clamps         | 1) Left Tail Pipe                |
| 2) F33 Flanges           | 1) Right Tail Pipe               |
| 6) 3/8" Nuts             | 6) 3/8" Lockwashers              |
| 6) 3/8" x 1-1/4" Bolts   | 1) Left Front Extension Pipe     |
|                          | 1) Right Front Extension Pipe    |

### **DANGER WARNING:**

Should the purchaser decide to install this exhaust product at home, be warned that pleasure car or light duty truck/van "bumper" jacks are intended for emergency use only. The use of frame contact jack stands in conjunction with a floor jack as main support is highly recommended to minimize accidental dropping of a vehicle while the installation proceeds. We recommend the use of a shop hoist if possible. Please use caution!

**Limitation of Liability–Disclaimers:** The regulation of emissions production, noise levels and safety standards is undertaken by the federal government, each of the fifty state legislatures, and by many local municipalities, towns and counties.

The manufacturer makes no warranties of merchantability, of fitness for a particular purpose, or that its products are approved for general use, or that its products comply with laws, regulations or ordinances in the states where they may be sold to the ultimate purchaser, the consumer.

The entire risk as to the conformity of this product in any such state and as to repair, should the product prove to be defective or non-conforming, is on the retail purchaser, the buyer, the ultimate consumer of such product and it is not upon the seller, distributor, or manufacturer.

In this connection, retail purchaser, the buyer, the ultimate consumer assumes the burden of the entire cost of any and all necessary service, alterations, and or repair.

The foregoing statement limits the liability of the manufacturer.



**1-800-345-4545**    **jegs.com**

**NOTE: DO NOT TIGHTEN ANY BOLTS OR CLAMPS UNTIL THE LAST STEP!**

1. Remove the old exhaust system after the headers. Remove the old hangers and brackets.
2. Install the left and right collector pipes using the MP48005 gaskets and F33 flanges. Tighten only enough to hold in place using the 3/8" x 1-1/4" bolts and nuts. NOTE: For vehicles requiring catalytic converters to meet EPA guidelines, catalytic converter #73-7774 or equivalent should be installed on the header collector pipes after the header collectors on the collector pipes.
3. Install the left and right front extension pipes to the collector pipes using 2-1/2" clamps. Be sure to leave adequate clearance between the floor boards and the drive shaft. NOTE: The extension pipes may be shortened to fit various header designs or different length mufflers.
4. Install the mufflers (not included, offset in/center out) onto the front extension pipes using 2-1/2" clamps. Rotate the front extension pipes to clear the driveshaft, and frame, and general clearance.
5. Mount the hanger brackets to the existing holes in the frame behind the rear axle using the lag screws and the snapper grommet (see drawing). The hangers should be installed to the tail pipes at where the tail pipes cross under the frame. Two additional hangers have been included to use at your preferred location.
6. Install the left and right tail pipes to the mufflers using 2-1/2" clamps. Use a 2-1/2" clamp to connect the pipes and a hanger.
7. Make sure that all the parts of the system are clear of frame members, all hoses, suspension, and brake and fuel lines. Starting at the collector pipes, tighten all connections and nuts. Make sure all parts are clear and will not leak or rattle. After several days of driving retighten all bolts.

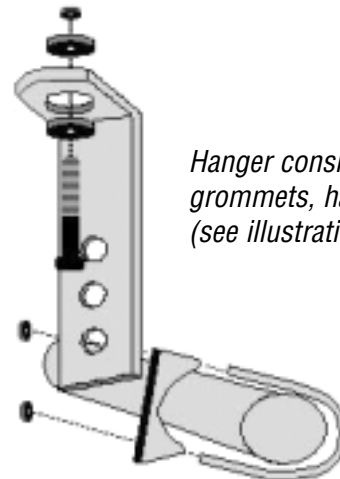
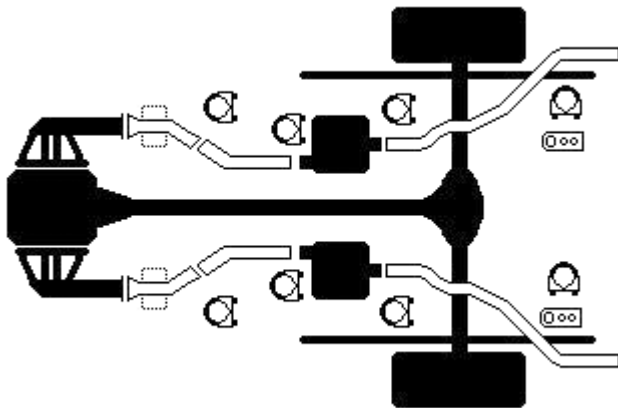

*Hanger consists of a strap hanger, grommets, hardware, and clamp (see illustration)*

## **Installation Instructions for 30541 2-1/2" Header Dual Kit w/o Mufflers**

**Application:** '64-'72 Chevelle/Malibu/El Camino, '65-'72 Buick Skylark, '65-'72 Oldsmobile Cutlass, '66-'72 Le Mans/Tempest, '69-'72 Grand Prix, '70-'72 Monte Carlo, all with V8, standard headers, and with 3" collectors at the headers.

NOTE: The headers and mufflers are not included in this kit!!

### **Kit Includes:**

- |                                  |                               |
|----------------------------------|-------------------------------|
| 2) LB9 Hangers                   | 1) Left Collector Pipe        |
| 2) Snapper Grommets              | 1) Right Collector Pipe       |
| 4) 5/16" x 1" Lag Screws         | 2) 5/16" Nuts                 |
| 10) 2-1/2" Clamps                | 1) Left Over-The-Axle Pipe    |
| 2) F33 Flanges                   | 1) Right Over-The-Axle Pipe   |
| 6) 3/8" Nuts                     | 1) Left Tail Pipe             |
| 6) 3/8" Lockwashers              | 1) Right Tail Pipe            |
| 6) 3/8" x 1-1/4" Bolts           | 2) BR1 Hangers (BR755)        |
| 2) Fender Washers                | 2) THU400 Hangers (BR104)     |
| 2) #MP48005 3" Collector Gaskets | 2) 5/16" x 1" Bolts           |
| 1) Left Front Extension Pipe     | 1) Right Front Extension Pipe |

### **DANGER WARNING:**

Should the purchaser decide to install this exhaust product at home, be warned that pleasure car or light duty truck/van "bumper" jacks are intended for emergency use only. The use of frame contact jack stands in conjunction with a floor jack as main support is highly recommended to minimize accidental dropping of a vehicle while the installation proceeds. We recommend the use of a shop hoist if possible. Please use caution!

**Limitation of Liability–Disclaimers:** The regulation of emissions production, noise levels and safety standards is undertaken by the federal government, each of the fifty state legislatures, and by many local municipalities, towns and counties.

The manufacturer makes no warranties of merchantability, of fitness for a particular purpose, or that its products are approved for general use, or that its products comply with laws, regulations or ordinances in the states where they may be sold to the ultimate purchaser, the consumer.

The entire risk as to the conformity of this product in any such state and as to repair, should the product prove to be defective or non-conforming, is on the retail purchaser, the buyer, the ultimate consumer of such product and it is not upon the seller, distributor, or manufacturer.

In this connection, retail purchaser, the buyer, the ultimate consumer assumes the burden of the entire cost of any and all necessary service, alterations, and or repair.

The foregoing statement limits the liability of the manufacturer.



**1-800-345-4545**    **jegs.com**

**NOTE: DO NOT TIGHTEN ANY BOLTS OR CLAMPS UNTIL THE LAST STEP!**

1. Raise the automobile in a safe and suitable manner. Support with jack stands onto the frame.
2. Remove the old exhaust system after the headers. Remove the old hangers and brackets if desired. New universal hangers are included in this kit to replace the original hangers.
3. Install the left and right collector pipes using the MP48005 gaskets and F33 flanges. Tighten only enough to hold in place using the 3/8" x 1-1/4" bolts and nuts.
4. Install the left and right front extension pipes to the collector pipes using 2-1/2" clamps. Be sure to leave adequate clearance between the floor boards and the drive shaft.
5. Install the mufflers (offset/offset, not included) onto the front extension pipes using 2-1/2" clamps. Rotate the front extension pipes to clear the driveshaft, and frame, and general clearance.
6. Mount the hanger brackets, if necessary, to the frame using the LB9 strap with the grommets and lag screw behind the mufflers, and the BR1 bracket, lag screw, and THU400 rubber hanger at the end of the tail pipes. Connect the hangers to the pipes using the 2-1/2" clamps.
7. Install the left and right over-the-axle pipes to the mufflers using 2-1/2" clamps. Install the left and right tail pipes to the over-the-axle pipes using 2-1/2" clamps. Use a 2-1/2" clamp to connect the pipes and a hanger at the rear. Cut the tail pipes to your desired length and look.
8. Make sure that all the parts of the system are clear of frame members, all hoses, suspension, and brake and fuel lines. Starting at the collector pipes, tighten all connections and nuts. Make sure all parts are clear and will not leak or rattle. After several days of driving, retighten all bolts.

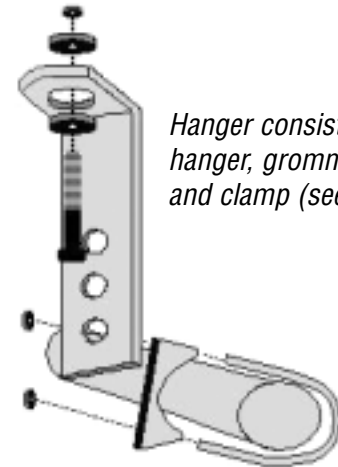
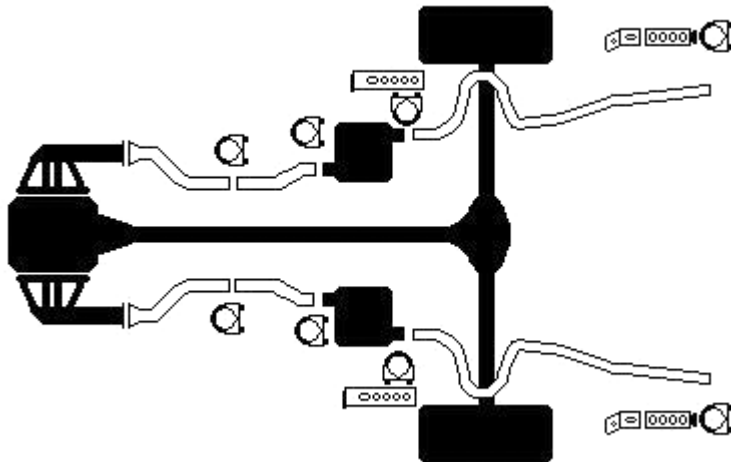

*Hanger consists of a strap hanger, grommets, hardware, and clamp (see illustration)*

## **Installation Instructions for 30542 2-1/2" Header Dual Kit w/o Mufflers**

**Application:** '73-'77 Chevelle/Malibu/El Camino, '73-'77 Oldsmobile Cutlass, '73 Le Mans/Tempest, '73-'77 Grand Prix, '73-'77 Monte Carlo, '73-'77 Buick Century/Regal, all with V8, standard headers, and with 3" collectors at the headers.

NOTE: The headers and mufflers are not included in this kit!!

NOTE: The catalytic converters are not supplied with this exhaust system. This system is not legal for on-road use on vehicles that originally were equipped with a catalytic converter.

### **Kit Includes:**

- |                          |                                  |
|--------------------------|----------------------------------|
| 2) LB9 hangers           | 1) Left Collector Pipe           |
| 2) Snapper Grommets      | 1) Right Collector Pipe          |
| 4) 5/16" x 1" Lag Screws | 2) THU400 Hangers (BR104)        |
| 10) 2-1/2" Clamps        | 1) Left Tail Pipe                |
| 2) F33 Flanges           | 1) Right Tail Pipe               |
| 6) 3/8" Nuts             | 1) Right Over-The-Axle Pipe      |
| 6) 3/8" Lockwashers      | 1) Left Over-The-Axle Pipe       |
| 6) 3/8" x 1-1/4" Bolts   | 2) #MP48005 3" Collector Gaskets |
| 2) Fender Washers        | 2) BR1 Hangers (BR755)           |
| 2) 5/16" x 1" Bolts      | 1) Left Front Extension Pipe     |
| 2) 5/16" Nuts            | 1) Right Front Extension Pipe    |

### **DANGER WARNING:**

Should the purchaser decide to install this exhaust product at home, be warned that pleasure car or light duty truck/van "bumper" jacks are intended for emergency use only. The use of frame contact jack stands in conjunction with a floor jack as main support is highly recommended to minimize accidental dropping of a vehicle while the installation proceeds. We recommend the use of a shop hoist if possible. Please use caution!

**Limitation of Liability–Disclaimers:** The regulation of emissions production, noise levels and safety standards is undertaken by the federal government, each of the fifty state legislatures, and by many local municipalities, towns and counties.

The manufacturer makes no warranties of merchantability, of fitness for a particular purpose, or that its products are approved for general use, or that its products comply with laws, regulations or ordinances in the states where they may be sold to the ultimate purchaser, the consumer.

The entire risk as to the conformity of this product in any such state and as to repair, should the product prove to be defective or non-conforming, is on the retail purchaser, the buyer, the ultimate consumer of such product and it is not upon the seller, distributor, or manufacturer.

In this connection, retail purchaser, the buyer, the ultimate consumer assumes the burden of the entire cost of any and all necessary service, alterations, and or repair.

The foregoing statement limits the liability of the manufacturer.



**1-800-345-4545**    **jegs.com**

**NOTE: DO NOT TIGHTEN ANY BOLTS OR CLAMPS UNTIL THE LAST STEP!**

1. Raise the automobile in a safe and suitable manner. Support with jack stands onto the frame.
2. Remove the old exhaust system after the headers. Remove the old hangers and brackets, if desired. New, universal hangers are included in this kit to replace the original hangers.
3. Install the left and right collector pipes using the MP48005 gaskets and F33 flanges. Tighten only enough to hold in place using the 3/8" x 1-1/4" bolts and nuts. NOTE: For vehicles requiring catalytic converters to meet EPA guidelines, catalytic converter #73-7774 or equivalent should be installed on the header collector pipes after the header collectors on the collector pipes.
4. Install the left and right front extension pipes to the collector pipes using 2-1/2" clamps. Be sure to leave adequate clearance between the floor boards and the drive shaft.
5. Install the mufflers (offset in/center out, not included) onto the front extension pipes using 2-1/2" clamps. Rotate the front extension pipes to clear the driveshaft, and frame, and general clearance.
6. Mount the hanger brackets, if necessary, to the frame using the LB9 strap with the grommets and lag screw behind the mufflers, and the BR1 bracket, lag screw, and THU400 rubber hanger at the end of the tail pipes. Connect the hangers to the pipes using the 2-1/4" clamps.
7. Install the left and right over-the-axle pipes to the mufflers using 2-1/2" clamps. Install the left and right tail pipes to the over-the-axle pipes using 2-1/2" clamps. Use a 2-1/2" clamp to connect the pipes and a hanger at the rear. Cut the tail pipes to your desired length and look.
8. Make sure that all the parts of the system are clear of frame members, all hoses, suspension, and brake and fuel lines. Starting at the collector pipes, tighten all connections and nuts. Make sure all parts are clear and will not leak or rattle. After several days of driving retighten all bolts.

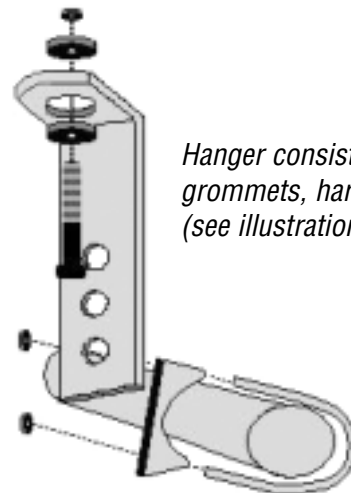
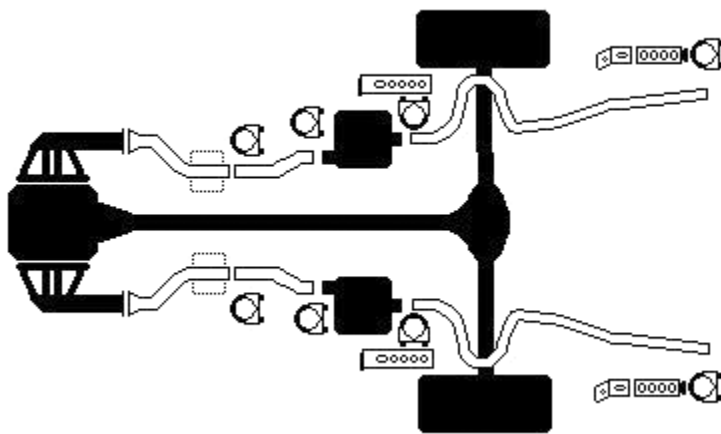

*Hanger consists of a strap hanger, grommets, hardware, and clamp (see illustration)*

## **Installation Instructions for 30543 2-1/2" Header Dual Kit w/o Mufflers**

**Application:** '64-'68 Mustang 289, 302, '69 Mustang 390, '69-'73 Mustang 289, 302, 351, '67-'68 Cougar 289, 302, 351, 390, 427, '70-'73 Cougar 351, 390, 400--all equipped with standard headers that exit straight from the motor.

NOTE: This kit will not bolt directly on vehicles with headers that exit not parallel to the drive shaft (angled exit). Modifications will be necessary for those with the angled exit type header.

NOTE: The catalytic converters are not supplied with this exhaust system. This system is not legal for on-road use for vehicles originally equipped with converters.

NOTE: The headers and mufflers are not included in this kit!!

### **Kit Includes:**

- |                                 |                                  |
|---------------------------------|----------------------------------|
| 2) 5/16" Lock Washers           | 1) Left Collector Pipe           |
| 2) BR3 brackets (BR855)         | 1) Right Collector Pipe          |
| 4) THU400 Rubber Hanger (BR104) | 1) Left Front Extension Pipe     |
| 8) 2-1/2" Clamps                | 1) Right Front Extension Pipe    |
| 2) F33 Flanges                  | 1) Right Tail Pipe               |
| 4) Fender Washers               | 1) Left Tail Pipe                |
| 4) 5/16" x 1" Lag Screws        | 2) 5/16" x 1" Bolts              |
| 2) 5/16" Nuts                   | 6) 3/8" x 1-1/4" Bolts           |
| 6) 3/8" Nuts                    | 2) #MP48005 3" Collector Gaskets |

### **DANGER WARNING:**

Should the purchaser decide to install this exhaust product at home, be warned that pleasure car or light duty truck/van "bumper" jacks are intended for emergency use only. The use of frame contact jack stands in conjunction with a floor jack as main support is highly recommended to minimize accidental dropping of a vehicle while the installation proceeds. We recommend the use of a shop hoist if possible. Please use caution!

**Limitation of Liability--Disclaimers:** The regulation of emissions production, noise levels and safety standards is undertaken by the federal government, each of the fifty state legislatures, and by many local municipalities, towns and counties.

The manufacturer makes no warranties of merchantability, of fitness for a particular purpose, or that its products are approved for general use, or that its products comply with laws, regulations or ordinances in the states where they may be sold to the ultimate purchaser, the consumer.

The entire risk as to the conformity of this product in any such state and as to repair, should the product prove to be defective or non-conforming, is on the retail purchaser, the buyer, the ultimate consumer of such product and it is not upon the seller, distributor, or manufacturer.

In this connection, retail purchaser, the buyer, the ultimate consumer assumes the burden of the entire cost of any and all necessary service, alterations, and or repair.

The foregoing statement limits the liability of the manufacturer.



**1-800-345-4545**    **jegs.com**

**NOTE: DO NOT TIGHTEN ANY BOLTS OR CLAMPS UNTIL THE LAST STEP!**

1. Remove the old exhaust system. Remove the old hangers.
2. Install the left and right collector pipes using the MP48005 gaskets and F33 flanges. Tighten only enough to hold in place, using the 3/8" x 1-1/4" bolts and nuts.
3. Install the left and right front extension pipes to the collector pipes using 2-1/2" clamps. Be sure to leave adequate clearance between the floor boards and the drive shaft.
4. Install the mufflers (double offset turbo-type recommended--not included in this kit) onto the front extension pipes using 2-1/2" clamps. Rotate the front extension pipes to clear the driveshaft, and frame.
5. Mount two of the THU400 rubber strap hangers to the back side of the floor boards by drilling a 1/4" hole on each side using a 5/16" lag screw and fender washer. The hanger should be installed above either the inlet or outlet of the mufflers, and the appropriate clamp from this connecting point should be used to connect the hanger to the pipe.
6. Install the left and right tail pipes to the mufflers using 2-1/2" clamps.
7. Install the BR3 "L" bracket to the rear frame using the 5/16" x 1" lag screw and fender washer, at a good location for a tail pipe hanger. A 1/4" hole may need to be drilled if none is present. Mount the remaining THU400 rubber hangers to the BR3 brackets using the 5/16" x 1" bolts, nuts, and lock washers. Use the remaining 2-1/2" clamps to connect the hanger assembly to the tail pipes.
8. Make sure that all the parts of the system are clear of frame members, all hoses, suspension, and brake and fuel lines. Starting at the collector pipes, tighten all connections and nuts. Make sure all parts are clear and will not leak or rattle. After several days of driving retighten all bolts.

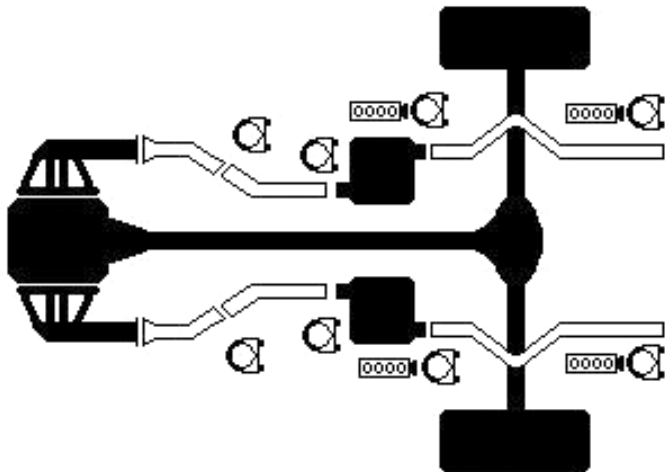



## **Installation Instructions for 30546 2-1/2" Muscle Car Header Dual Kit w/o Mufflers**

**Application:** '78-'88 G-body GM mid-size cars, Malibu, Oldsmobile Cutlass (excluding Cutlass Supreme), Le Mans, Grand Prix, Monte Carlo, Buick Regal, all with small block V8, standard headers, and with 3" collectors at the headers.

NOTE: The headers and mufflers are not included in this kit! We recommend usage of Dynomax part # 85121 or 86121 for best fit of this exhaust system.

NOTE: You will need a double-hump cross member for installation of this kit. Please order Jeg's #550-41050. This kit will not fit properly with the stock cross member in place.

NOTE: The catalytic converters are not supplied with this exhaust system. This system is not legal for on-road use on vehicles that originally were equipped with a catalytic converter.

### **Kit Includes:**

- |                              |                                  |                                 |
|------------------------------|----------------------------------|---------------------------------|
| 4) LB7 Hangers               | 2) 3" to 2-1/2" Collectors       | 6) 3/8" Lockwashers             |
| 4) Snapper Grommets          | 1) Right Extension Pipe #2268712 | 6) 3/8" x 1-1/4" Bolts          |
| 2) 5/16" x 1-1/4" Lag Screws | 1) Left Extension Pipe #2268711  | 2) MP48005 3" Collector Gaskets |
| 8) 2-1/2" Clamps             | 1) Left Tail Pipe #2268713       | 4) 5/16" x 1-1/2" Bolts         |
| 2) F33 Flanges               | 1) Right Tail Pipe #2268714      | 4) 5/16" Nuts                   |
| 6) 3/8" Nuts                 | 2) Tail Pipe Extensions #2268715 |                                 |

### **DANGER WARNING:**

Should the purchaser decide to install this exhaust product at home, be warned that pleasure car or light duty truck/van "bumper" jacks are intended for emergency use only. The use of frame contact jack stands in conjunction with a floor jack as main support is highly recommended to minimize accidental dropping of a vehicle while the installation proceeds. We recommend the use of a shop hoist if possible. Please use caution!

**Limitation of Liability—Disclaimers:** The regulation of emissions production, noise levels and safety standards is undertaken by the federal government, each of the fifty state legislatures, and by many local municipalities, towns and counties.

The manufacturer makes no warranties of merchantability, of fitness for a particular purpose, or that its products are approved for general use, or that its products comply with laws, regulations or ordinances in the states where they may be sold to the ultimate purchaser, the consumer.

The entire risk as to the conformity of this product in any such state and as to repair, should the product prove to be defective or non-conforming, is on the retail purchaser, the buyer, the ultimate consumer of such product and it is not upon the seller, distributor, or manufacturer.

In this connection, retail purchaser, the buyer, the ultimate consumer assumes the burden of the entire cost of any and all necessary service, alterations, and or repair.

The foregoing statement limits the liability of the manufacturer.



**1-800-345-4545**    **jegs.com**

**NOTE: DO NOT TIGHTEN ANY BOLTS OR CLAMPS UNTIL THE LAST STEP!**

1. Raise and support the automobile in a safe and suitable manner-support with jack stands onto the frame.
2. Remove the old exhaust system after the headers. Remove the old hangers and brackets if desired. New universal hangers are included in this kit to replace the original hangers. If you have not done so yet, install the double-hump cross member Jeg's # 550-41050, or modify your existing cross member.
3. Install the 3" to 2-1/2" collectors to the headers using the MP48005 gaskets and F33 flanges. Tighten only enough to hold in place, using the 3/8" x 1-1/4" bolts and nuts. On certain models it may be necessary to trim about 1-1/2" off of the header collectors for proper length of the system.
4. Install the left and right extension pipes to the collectors using 2-1/2" clamps. Be sure to leave adequate clearance between the floor boards, double-hump cross member, and the drive shaft. The inlet on both extension pipes is the I.D. or expanded end. The left extension pipe has a longer straight section on the inlet end than the right extension pipe.
5. Install the mufflers (offset/offset, not included) onto the front extension pipes using 2-1/2" clamps. Rotate the front extension pipes to clear the driveshaft, cross member, frame, floor, and general clearance.
6. Mount the hanger brackets if necessary to the frame using the LB7 strap with the grommets and 5/16" x 1-1/2" bolts and nuts (or lag screws) directly above the outlet of the mufflers, connect the hangers to the outlet of the mufflers using 2-1/2" clamps.
7. Install the left and right tail pipes to the mufflers using the same 2-1/2" clamps used in step 6). NOTE: on the right side, be aware of the fuel lines. Be sure to have adequate clearance and no leaks.
8. Install the left and right tail pipe extensions to the tail pipes using 2-1/2" clamps. Use these 2-1/2" clamps to connect the tail pipes, the tail pipe extensions, and an LB7 hanger and grommet at the rear on both sides. You will need to drill a hole in the frame for the hangers. Cut the tail pipes to your desired length and look.
9. Make sure that all the parts of the system are clear of frame and cross members, all hoses, suspension, and brake and fuel lines. Starting at the collectors, tighten all connections and nuts. Make sure all parts are clear and will not leak or rattle. After several days of driving retighten all bolts.

