

Installation Instructions for 50523 LS-Series Engine Swap Adapter Plates

Includes:

- (1) LS Series Driver side Engine Swap Adapter Plates
- (1) LS Series Passenger side Engine Swap Adapter Plates
- (4) 3/8"-16 x 1.25" Flat Head Socket Cap Screws
- (4) 3/8"-16 nut
- (4) 3/8" Split Lock Washer
- (4) 3/8" Flat Washer
- (2) M10x1.5x25mm Flat Head Socket Cap Screws
- (6) M10x1.5x35mm Hex Head Socket Cap Screws
- (6) 10mm Flat Washer
- (6) 10mm Split Lock
- (1) Anti-Seize

Installation Instructions:

1. First, remove factory motor mounts (if present).
2. Install the (2) 3/8"-16 x 1.25" Flat Head Socket Cap Screws with **Blue Bolt Locker** (we recommend part number 555-28084) or **Loctite®** into adapter plate.
3. Install the adapter plate with the (2) 3/8"-16 x 1.25" Flat Head Socket Cap Screws facing away from the block and (1) M10x1.5 x 25mm Flat Head Socket Cap Screw with **Anti-Seize** into the block.
4. Install (2) M10x1.5 x 35mm Hex Head Cap Screw with (1 ea.) 10mm Flat Washer, (1 ea.) 10mm Split Lock Washer and **Anti-Seize** on each bolt into the block. **Torque all of the M10 Flat Head Socket Cap Screws to 37 ft. lbs.**
5. Install your motor mounts (we recommend part numbers (**Not Included**) 555-50510, 555-50511, 555-50512, 555-50513 or 555-50515 depending on your application)). Install the motor mount onto (2) 3/8"-16 studs with (1 ea.) 3/8" flat washer, (1 ea.) 3/8" split lock washer, (1 ea.) 3/8"-16 nut and **Blue Bolt Locker or Loctite®** on each bolt. **Torque to 40 ft. lbs.**
6. Install the (1) M10x1.5 x 35mm Hex Head Cap Screw with (1 ea.) 10mm Flat Washer, (1 ea.) 10mm Split Lock Washer and **Anti-Seize** through the motor mount and into the block. **Torque to 37 ft. lbs.**

Repeat steps 2 thru 6 on the opposite side

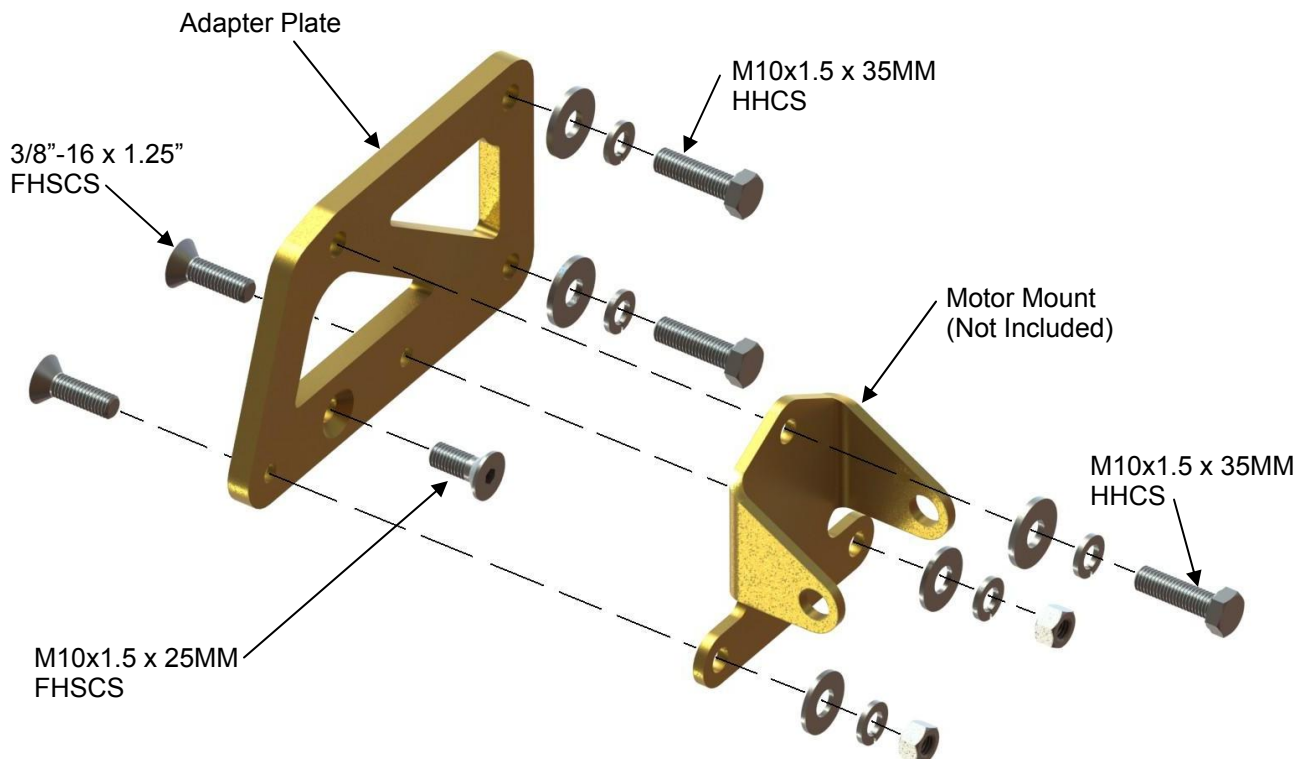

1-800-345-4545 jegs.com