

# In-Tank Pump DW300m (9-305)



This 340lph DW300m is the only 300+ LPH pump with drop-in fitment for the Ford Mustang GT, and the GT500 dual pump module. To achieve Ford-specific fitment, we engineered this pump to replicate the OE's unique compact size, end cap geometries, electrical connector, and outlet barb. The result is a 340LPH pump that precisely installs into Ford modules with no wire splicing, no hacking, and no zip-ties. A single DW300m will support over 500hp on any 2v/3v mustang. In addition the DW300m is compatible with pulse with modulated pump drivers and is fully compatible with ethanol blended fuels. All DW fuel pumps are backed by a 3-year no fault warranty.

To ensure maximum voltage at the pump, a 12-gauge hardwire kit is strongly recommended for optimum performance (DeatschWerks part #FPHWK)

## Specifications

<b>Weight</b>	10.6oz (300g)
<b>External Materials</b>	Electroplated Steel
<b>Inlet Fitting</b>	7.7mm ID, 11.0mm OD
<b>Outlet Fitting</b>	5/16" Hose Clamp
<b>PRV Activation</b>	100 psi
<b>Impeller Design</b>	Single Scroll Composite Turbine
<b>Connector Terminal</b>	Spade Pos/Neg
<b>Min Voltage Input</b>	6 Volts
<b>Max Voltage Input</b>	18 Volts
<b>Current Draw 40psi</b>	11.2 Amps (13.5v)

## Delivery Characteristics

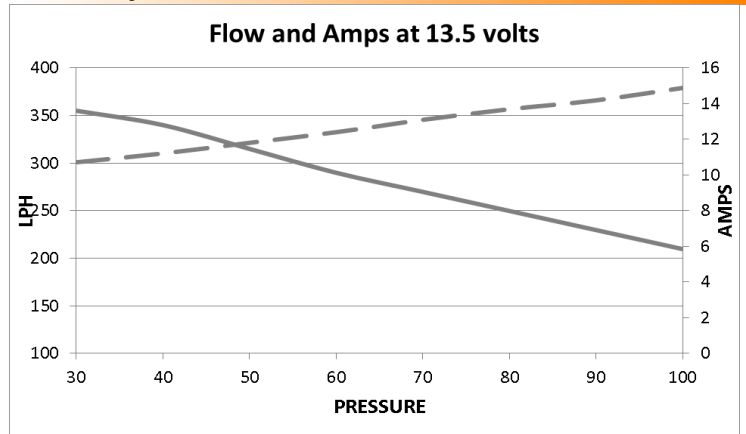

PSIG	30	40	50	60	70	80	90	100
AMP	10.7	11.2	11.8	12.4	13.1	13.7	14.2	14.9
LPH	355	340	315	290	270	250	230	210

## Dimensions

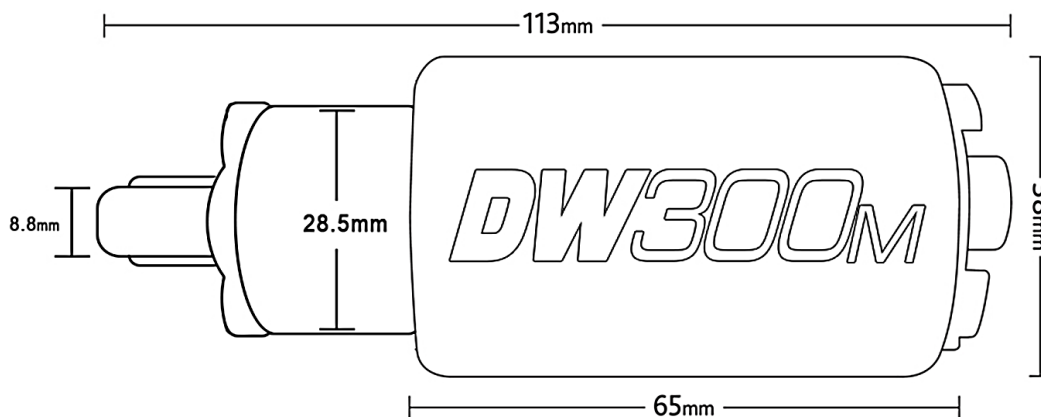

THIS PRODUCT MAY BE USED SOLELY ON VEHICLES USED IN SANCTIONED COMPETITION WHICH MAY NEVER BE USED UPON A PUBLIC ROAD OR HIGHWAY, UNLESS PERMITTED BY SPECIFIC REGULATORY EXEMPTION