

DIRECTION 166

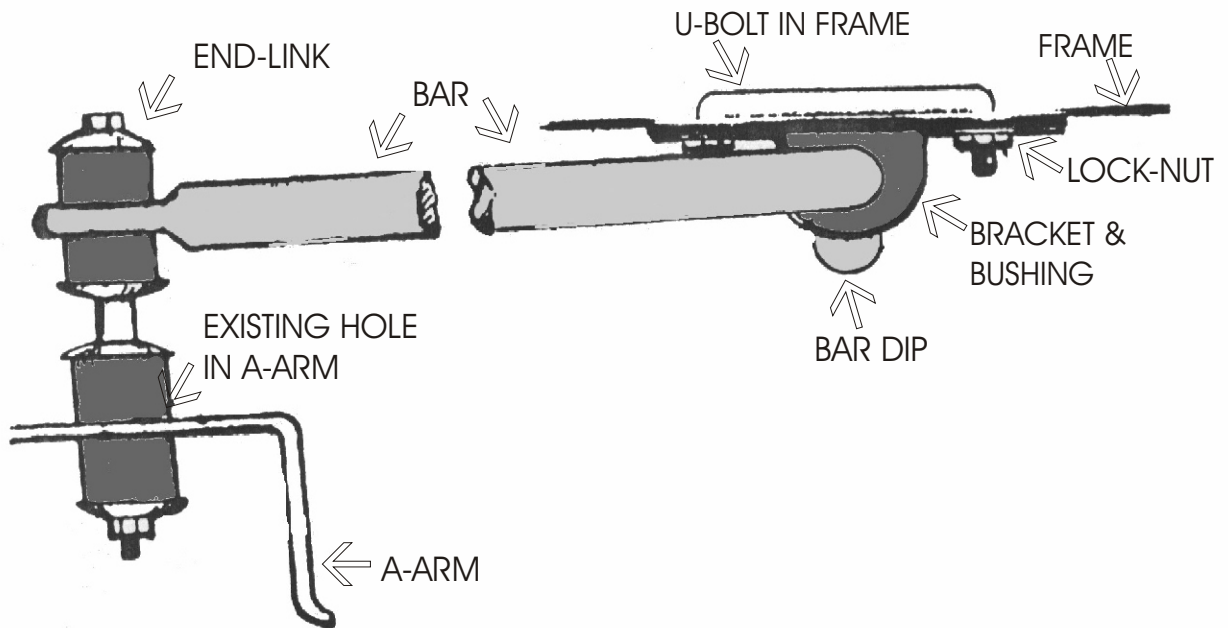

Direction #166

Step #1. Place the bushing on the bar mid-section. Assemble the end-links as shown so that they connect the bar eyes to the existing hole in the A-arm. The bar end is above the suspension arm. Tie the middle of the bar up with string to facilitate the installation.

Step #2. Place the midsection bushings on the bar and the frame bracket over the bushing and position both in the center of the frame bottom. Mark through the holes of the frame bracket and spacer plate on the frame bottom for drilling. Drill the frame bottom with a 3/8" drill bit.

Step #3. Place a nut on one end of the U-bolt, then insert the other end through the hole in the frame bracket; and then into one of the holes in the frame bottom. Maneuver until it reappears through the other hole and then pass it through the other hole of the bracket and secure with a second nut.

Step #4. Check all fastenings for suitable tightness (do not over tighten the lock-nut on the end-link so as to distort bushings). Have someone bounce the front of the car so as to check that the installation clears all other parts throughout the suspension travel distance. Road test the car to accustom yourself to your car's new handling. As we cannot supervise your installation or driving, we cannot be held responsible for than the cost of the kit.

NOTE: For best results and balanced cornering, this kit should be used in conjunction with our rear bar.

HARDWARE

2	RH 509 Bushings
2	RH 402 U-Bolts
4	RH 304 Lock-Nuts
2	RH 040 Brackets
2	RH 015 End-links