

DIRECTION 263

U-BOLT DETAIL

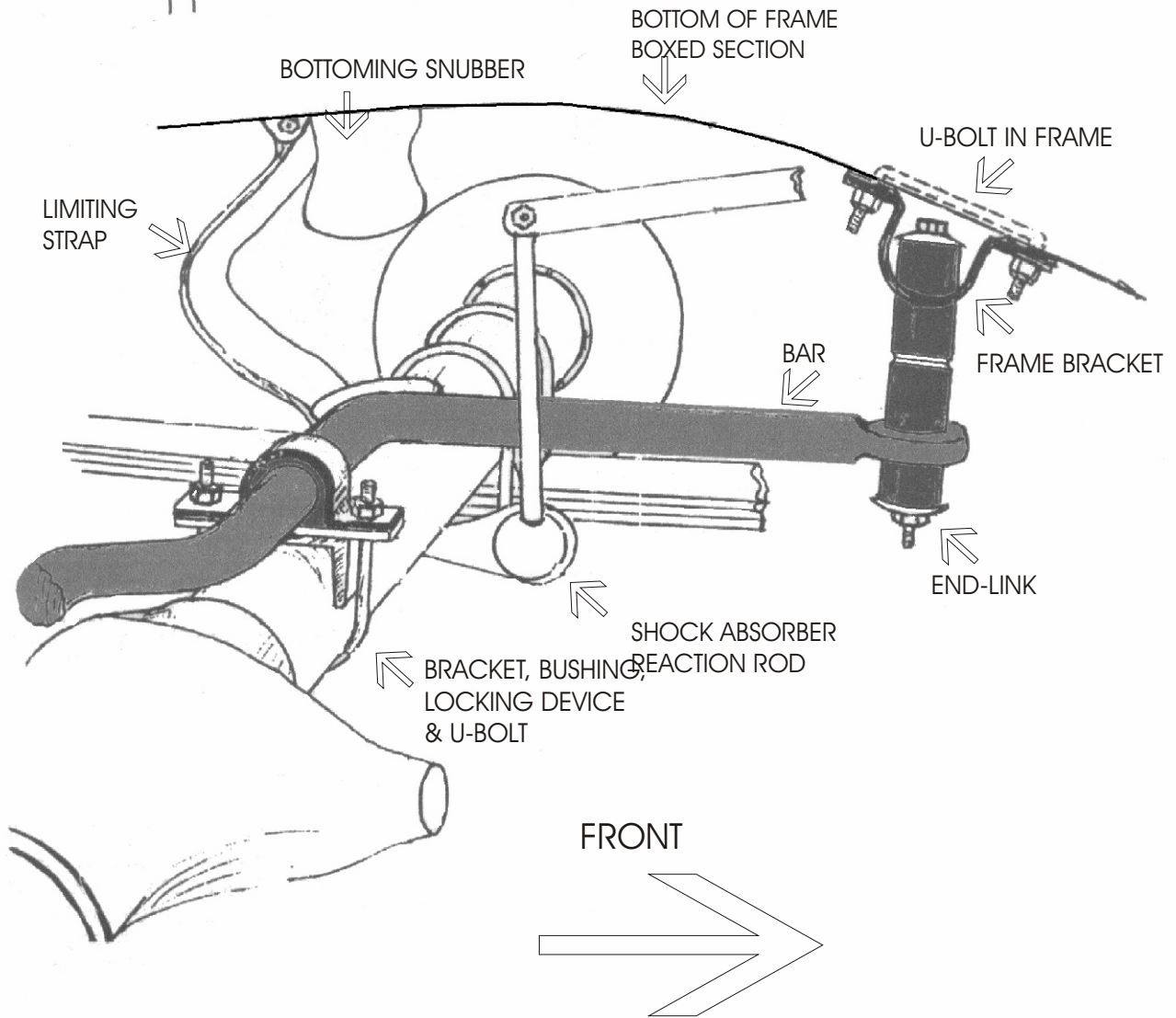
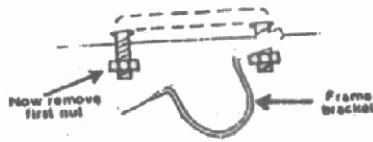
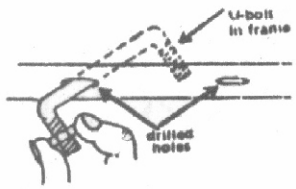

Direction 263

- Step #1.** Place the bar in position on top of the axle, dip up, arms leading to the front. On top of the axle towards the shoulders of the bar place the locking device and plate which will now be between the axle and the bar. Over the bar and aligning with the plate place the bar bracket. Pass the large U-bolt up from below the axle, through the holes in the plate and bar bracket and start the nuts. Be sure that the U-bolt or other parts are between the brake-line and the axle so as not to crush them. Pull the brake-line away from the axle slightly if needed.
- Step #2.** Place the D-shaped bushing on the bar mid-section and slide it under the bar bracket. Adjust the position of the bracket and U-bolts about the axle so that they give clearance to brake-line "T", rear end breather, etc, and so that they hold the bar in the most suitable position along the axle on the two sides. Tighten the U-bolt nuts sufficiently to keep assembly in position during installation.
- Step #3.** Assemble end-links onto bar ends. Center bolt passes through; cupped washer, rubber bushing, frame bracket (from inside bracket), rubber bushing, rubber bushing, bar eye, rubber bushing, cupped washer, and finish with nut. This nut should only be tight enough to keep assembly snug.
- Step #4.** Raise bar arms so that frame bracket are against frame bottom. Mark through holes in the bracket for drilling. Be sure the car is resting on its spring when doing this. Drill holes with a 3/8" drill bit with the same spacing as the short legged square U-bolt.
- Step #5.** Place a nut on the U-bolt and insert the other end into one hole; maneuver until it reappears from the other hole. Pass it through one hole in the bracket and start another. Remove the first nut and replace having put over the bracket. Tighten nuts to secure U-bolt and bracket.
- Step #6.** Having someone bounce the rear of the car so that you can check for clearance throughout the suspension travel distance. Tighten the nuts on the axle U-bolts to 10 ft/lbs. Check to make sure they are holding securely. Road test the vehicle to familiarize yourself to its new handling. As we cannot supervise your installation or driving, we cannot be held responsible for more than the cost of the kit.

NOTE: For balance and control this kit should be used in conjunction with our front bar.

HARDWARE

2	RH 013 End-Links
8	RH 304 Lock-Nuts
2	RH 044 Brackets
2	RH 402 U-Bolts
2	RH 046 Brackets
2	RH 507 Bushings
2	RH 031 Plates
2	RH 055 Brackets
2	RH 407 U-Bolts
4	RH 104 Washers