

DIRECTION 265

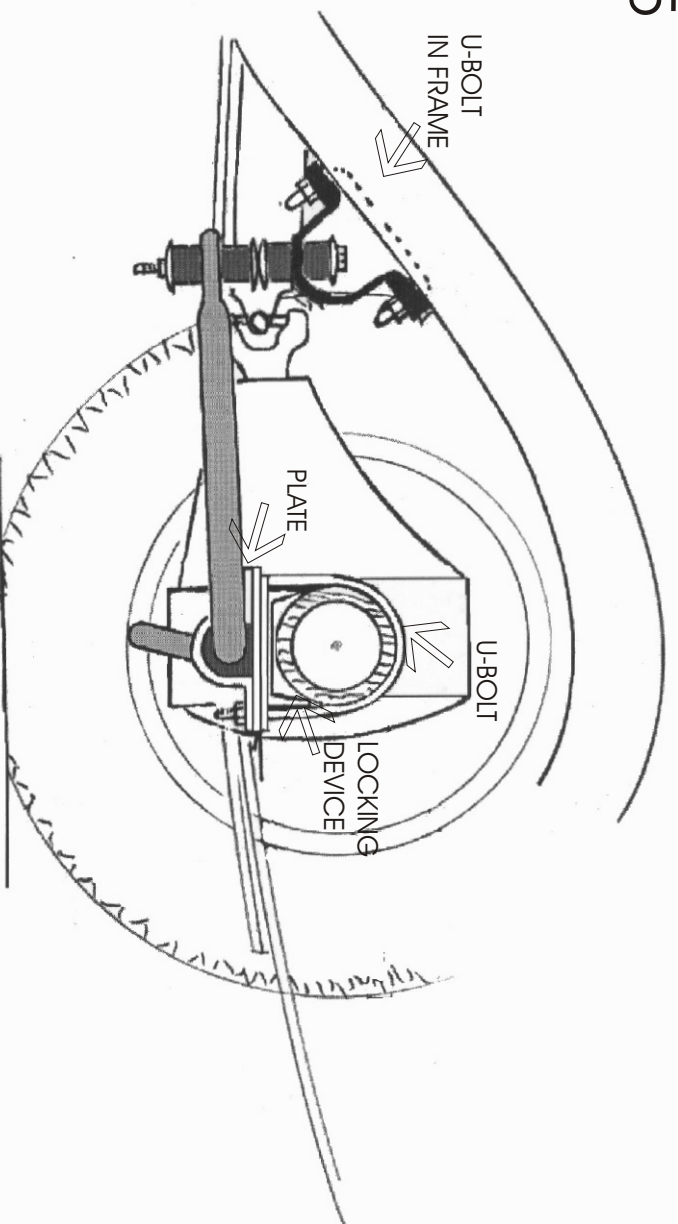

405 U-BOLT SETUP

HOW TO INSTALL A 402 U-BOLT

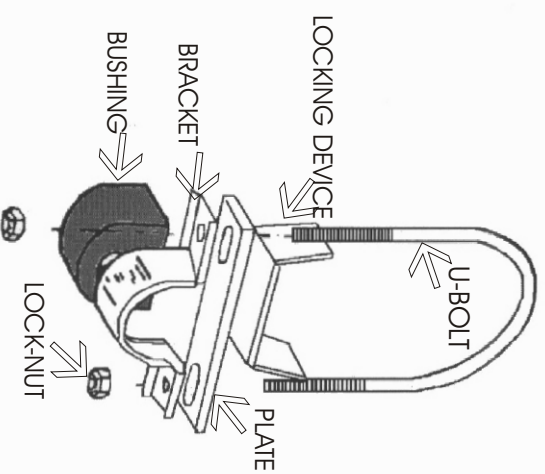
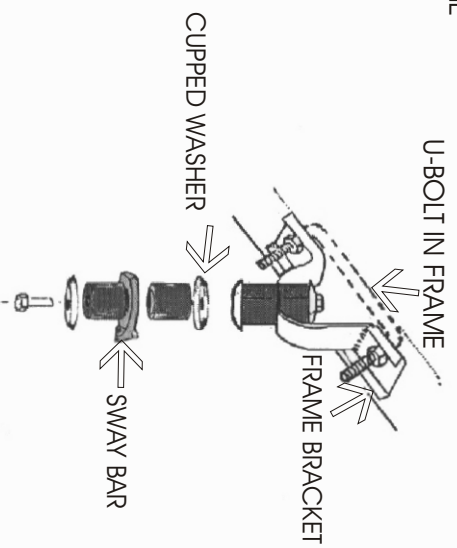
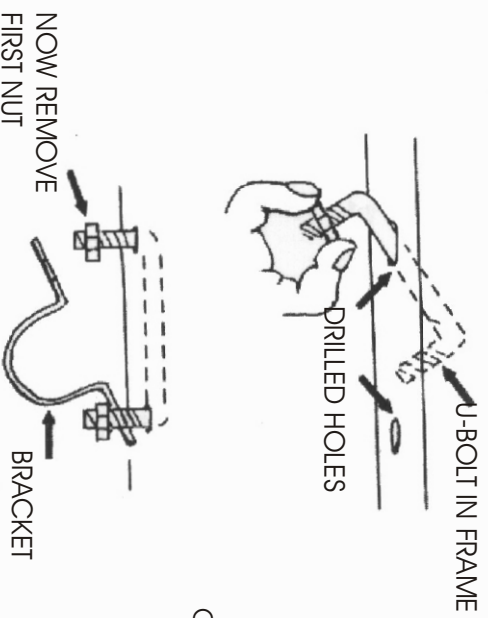

Direction 265

- Step #1.** Hang U-bolt around axle. Be sure they are passed under the brake line so as not to pinch them. Raise up the slotted plates under the U-bolt so as to engage the U-bolt legs. Follow with the bar bracket that should already be around under the bar. Start the nuts. Place the D-shaped rubber bushing on the bar near the bends, flat side up. Next, slide the loosely assembled U-bolt and bracket assembly down the axle so that the bracket is around the rubber bushing. Insert the locking device from one side, legs toward axle. Center on slotted plate. Bar dip should be under differential and the arms forward.
- Step #2.** Assemble end-link as illustrated. Pass the end-link center bolt through one cupped washer; through a rubber bushing; through the frame bracket (from inside it); through two more bushings with washers in between, the bar eye; another bushing, the last cupped washer; and secure with a lock-nut. Be sure that washers have their cupped or hollow side towards the rubber bushing and that the rubber bushing has the end with the stepped surface towards the bracket or bar eye. Tighten the lock-nut so the assembly is securely snug but not so tight that the bushing bulge to a noticeable extent.
- Step #3.** Position bar so that the forges are horizontal and the axle clamp assembly holding the bar mid-section below the axle. With the car resting naturally on its springs on level ground, the frame brackets should position themselves so as to align with the frame bottom. Adjust the bar position relative to the axle if needed.
- Step #4.** Mark through the frame bracket holes. Drill one hole with a 3/8" drill bit. Use the square U-bolt to get the exact spacing for the second hole and drill it.
- Step #5.** Place a lock-nut on one leg of the square U-bolt. Insert the other end into one drilled hole. Maneuver it until it reappears through the other drilled hole. Place one end of the frame bracket over the leg and start another lock-nut on it. Remove the first nut; position free end of bracket over the U-bolt leg and replace the nut.
- Step #6.** Have someone bounce the rear of the car so you can check that all parts of the bar and hardware clear throughout the suspension travel distance. Measure the maximum travel distance so you can better estimate clearances. If all is clear, tighten nuts on the frame and axle.
- Step #7.** Road test the vehicle to familiarize yourself with its new handling. As we cannot supervise your installation or your driving, we cannot be held responsible for more than the cost of the kit.

HARDWARE

2	RH 013 End-Links	2	RH 405 U-Bolts
2	RH 044 Brackets	2	RH 054 Channel Brackets
2	RH 043 Brackets	2	RH 031 Plates
2	RH 507 Bushings	2	RH 402 U-Bolts
8	RH 304 Lock-Nuts	4	RH 104 Washers