

DIRECTION 273

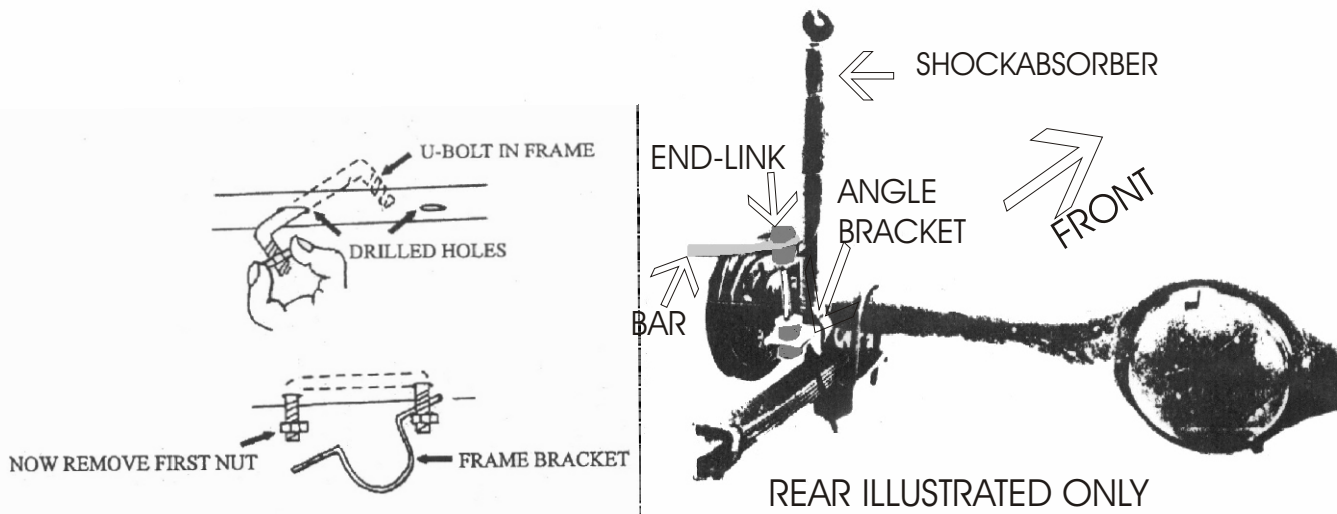

Direction 273

- Step #1.** Unfasten lower end of the shock absorber, discard the washer and refasten with the short side of the angle bracket taking the place of the washer. Position with large side of the angle bracket horizontal and above the shock stud as illustrated.
- Step #2.** Position bar so its eyes are over the holes in the horizontal side of the angle bracket (the front bar should be over the frame, just forward of the grill, the rear bar under the frame to the rear of the axle). Tie rear bar up with string for convenience.
- Step #3.** Assemble end-links illustrated so as to connect angle bracket hole and bar eye with rubber bushings, raised end fitting into the bar eye and the bracket hole and cupped washers next to the bushing and the spacer at the center.
- Step #4.** Place the D-shaped bushing on the bar next to the frame. Place the bracket around it so as to hold it to the frame and mark frame through bolt holes. Drill holes with a 3/8" drill bit.
- Step #5.** Attach bracket base-plate, bar and bushing to the frame as outlined in general direction. (On the front bar, as the brackets will be on the top side of the frame, the illustration should be inverted).
- Step #6.** Check all fastenings for suitable tightness and bounce the car so as to check clearance throughout the suspension travel distance and steering lock to lock. Road test the vehicle to familiarize yourself to its new handling. As we cannot supervise your installation or driving, we cannot be held responsible for more than the cost of the kit.

HARDWARE

2	RH 016 End-Links	2	RH 507 Bushings
2	RH 040 Brackets	2	RH 023 Angles Brackets
2	RH 402 U-Bolts	4	RH 304 Lock-Nuts