



Part #697

8-23-2005

- Step 1.** Disconnect the lower ends of the shock absorbers. From the front side, pass two bolts through the existing holes in the shock standoff bracket to engage the corresponding holes in the mounting plate. See the illustration for the positioning to compensate for the angle of the shock standoff. The plate should be held with the top horizontal. Tighten the lock-nuts to 30 ft./lbs.
- Step 2.** Place the D-bushings and brackets around the bar mid-section and start the bolts to the holes on the inboard side of the mounting plate. Note that the bar arms should be pointing forward and the center dip should pass to the rear of the bottom of the differential. Tighten the bolts to 25 ft./lbs.
- Step 3.** Locate the 5/8" existing hole on the out side of the frame rail approximately 12" forward of the axle. Using the 1/2" fasteners provided attach the angle bracket to the outside of the frame rail with the vertical side pointing downward. Place the bolt through the angle bracket so that the nut and lo washer is on the inside of the frame rail. Tighten so that the bracket can still pivot for final alignment. **NOTE: For 1997 models drill 1/2" hole located by the oval shape, where the emergency brake cable goes through.**
- Step 4.** Assemble the end-links as shown so as to connect the eye of the bar to the angle bracket. Tighten end-links so that they are just snug. **NOTE: Do not over tighten end-links or it will result in end-link failure!!** Now adjust angle brackets for proper alignment and torque 1/2" bolts to 45 ft./lbs.
- Step 5.** Check all fastenings for proper torque. Bounce the rear of the van while you check the movement of the spring to be sure that the spring cannot contact the angle bracket, and all other parts clear throughout the suspension travel distance. The installation is now complete. As we cannot supervise your installation or driving, we cannot be held responsible for more than the cost of the kit.

#### Hardware

2 RH 036 Angle Bracket  
2 RH 316 Nuts  
2 RH 114 Washers  
2 RH 110 Flat Washers  
8 RH 304 Lock-Nuts  
2 RH 231 Bolts

2 RH 046 Brackets  
2 RH 511 Bushings  
2 RH 607B Plates  
2 RH 005 End-Links  
8 RH 214 Bolts

# DIRECTION 697

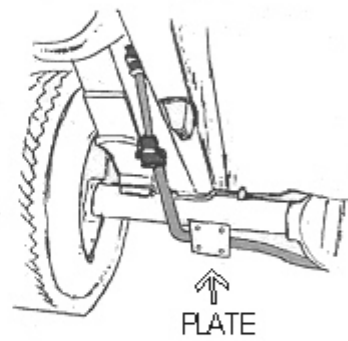

## END-LINK ASSEMBLY

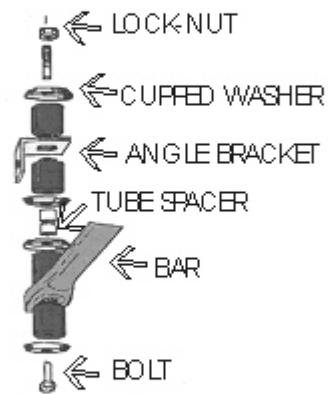

## E-250 & E-350

