

DIRECTION 723

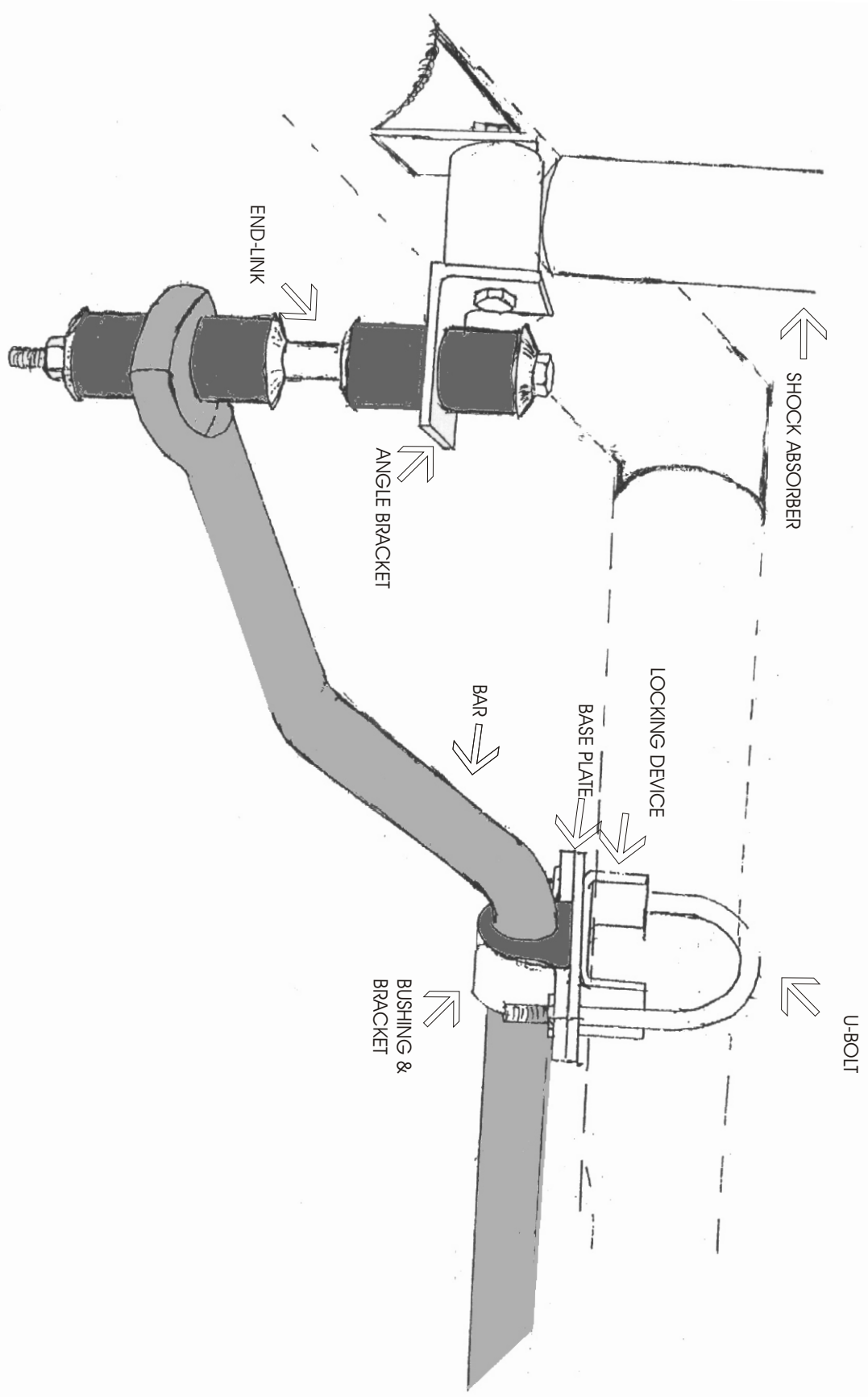

DIRECTIONS 723 VW BUS/VAN-FRONT

- STEP #1.** **Remove the lower shock absorber bolts. Place the angle brackets as illustrated and replace the bolts securely.**
- STEP #2.** **Assemble the end-link as illustrated so it connects the large hole in the angle brackets with the bar eyes. Tighten the lock nut on the end-link only enough to keep the assembly snug.**
- STEP #3.** **Place the D-shaped bushings on the bar mid-section near the bends. Hang the U-bolts over the torque-tube above the D-bushings. Engage abase plate and bar bracket on the U-bolts legs and start the lock-nuts. Slide the locking device in and tighten the lock-nuts to 20lbs/ft. So it securely locks the assembly on the torque tube.**
- STEP #4.** **Check all fastenings for suitable tightness. Test drive the van to familiarize yourself to its new handling. As we cannot supervise your installation or driving, we cannot be held responsible for more than the cost of the kit. For best balance, stability, and highway tracking, this kit should be used in conjunction with our rear kit #952.**

HARDWARE

2	RH 046	Brackets
2	RH 055	Brackets
2	RH 407	U-Bolts
2	RH 031	Plates
4	RH 104	Washers
2	RH 508	Bushings
4	RH 304	Lock-Nuts
2	RH 014	End-Links
2	RH 023	Angle Brackets