



About Us

ACES Fuel Injection specializes in developing and manufacturing state-of-the-art performance-engine management systems and ignition components geared toward do-it-yourself automotive enthusiasts. Our company was founded on an electromechanical engineering background, and our talented staff always keeps a grip on the newest technology available. We use our expertise to guarantee top-notch quality components and constant innovation of new products and services for car and truck enthusiasts around the world.

Our greatest advantage is the overall simplicity of our products. From a painless installation to real-time tuning in just hours, our fuel injection systems offer a great advantage over the competition. Our ROYAL FLUSH™ Throttle Body EFI system with integrated CDI ignition capabilities features a built-in interface that allows users to have full control of the engine without the need of a PC. This allows you to install the system at home without the need of special tools or software. We also offer several other components to help seamlessly integrate our advanced technology into your vehicle.

Our craftsmanship and technology are built upon a foundation of extreme performance. With a history of producing winning results in a wide variety of applications, our pedigree offers proof of our commitment to attain the best results, wherever we compete. With more than 10 years of experience developing and designing high-performance products, ACES Fuel Injection has a product to fit your needs.

Mission

Research, innovate, and develop real, efficient, quality solutions, making engine management technology the key factor of success, and bring pride and satisfaction to customers by integrating them into the ACES Fuel Injection Team.

Vision

Become the world's leading company in engine management technology.

Values

Ethics, commitment, professionalism, teamwork, quality, pioneering spirit, creativity, continuous innovation, pursuit of results and customer satisfaction.

Table of Contents

| | |
|--|-----------|
| Royal Flush™ THROTTLE BODY EFI OVERVIEW..... | 5 |
| Parts List..... | 6 |
| ADVANCED USER CAPABILITIES..... | 6 |
| WARNINGS, NOTES, AND NOTICES..... | 6 |
| 1.0 Introduction and System Requirements..... | 8 |
| 1.1 Engine Requirements..... | 8 |
| 2.0 Installation..... | 8 |
| 2.1 Throttle Body Installation..... | 8 |
| 2.2 Fuel System..... | 11 |
| 2.3 Oxygen Sensor Installation..... | 12 |
| 2.4 Coolant Temperature Sensor Installation..... | 13 |
| 2.5 Boost Reference Port..... | 14 |
| 3.0 ECU Mounting and Wiring Overview..... | 14 |
| 3.1 ECU Wiring Overview..... | 16 |
| 4.0 Wiring Installation..... | 18 |
| 4.1 Harness Routing..... | 18 |
| 4.2 Sensor Connection..... | 18 |
| 4.3 Ignition Coil (With Timing Control)..... | 19 |
| 4.4 Loose Wires..... | 20 |
| 4.5 Additional Wires..... | 20 |
| 5.0 Handheld Controller..... | 21 |
| 6.0 Ignition Wiring..... | 21 |
| 6.1 No Timing Control..... | 23 |

| | |
|--|-----------|
| 6.2 Timing Control..... | 23 |
| 8.0 Handheld Controller Navigation and Use..... | 25 |
| 8.1 Making Adjustments..... | 26 |
| 8.2 Connection..... | 27 |
| 8.3 Navigation buttons..... | 27 |
| 8.4 Main Menu..... | 28 |
| 9.0 Calibration Wizard..... | 29 |
| 10.0 Sensor Verification..... | 33 |
| 11.0 Startup Engine..... | 33 |
| 12.0 After Startup..... | 34 |
| 13.0 Timing Verification..... | 35 |
| 13.1 No Timing Control..... | 35 |
| 13.2 Timing Control..... | 35 |
| 14.0 Idle Setting..... | 35 |
| 15.0 Self-Tuning..... | 36 |
| TUNING REFERENCE MANUAL..... | 37 |
| 1.0 IDLE..... | 38 |
| 1.1 Basic Idle Parameter..... | 39 |
| 3.2 Advanced Idle Parameter..... | 40 |
| 2.0 SPARK..... | 42 |
| 2.1 Basic Spark Parameter..... | 42 |
| 2.2 Advanced Spark Parameter..... | 43 |
| 3.0 FUEL..... | 45 |
| 3.1 Basic Fuel Parameter..... | 45 |
| 3.2 Advanced Fuel Parameter..... | 46 |

| | |
|---|-----------|
| 4.0 Fuel Pump | 48 |
| 4.1 Turn Off RPM | 48 |
| 4.2 Key-On Pump Hold Time | 48 |
| 4.3 Turn Off After Lose RPM | 48 |
| 5.0 System Setting | 48 |
| 5.1 Basic System setting | 48 |
| 5.2 Advanced System setting | 49 |
| 6.0 System IO | 50 |
| 7.0 Rev Limiter | 51 |
| 7.1 Rev Limiter Basic Setting | 51 |
| 7.2 Rev Limiter Advanced Setting | 53 |

Royal Flush™ THROTTLE BODY EFI OVERVIEW

ACES Fuel Injection Royal Flush Self-Tuning EFI system is the most powerful TBI, using the most advanced technology. ACES Fuel Injection provides the latest EFI innovation for this system by integrating with EFI control module and a CDI ignition system in one ECU. This is a revolutionary upgrade and huge leap forward world of after-market EFI products. Using ACES' Royal Flush EFI system to convert and upgrade traditional engines, customers can control engine's fuel injection and high-energy ignition with only one ECU and one controller, which not only saves money, but also simplifies the installation for our customers. ACES will continue to provide customers with reliable and high-quality products, while also providing the latest innovative technology and products.

The ACES Fuel Injection Royal Flush EFI system supports up to 650 hp with four 100 lb./hr. Injectors and outputs 220 mj spark energy. The cutting-edge system includes a throttle body assembly (with the injectors, TPS, MAP, IAT, stepper motors installed) wire harness, ECU, handheld programmer/monitor, wide band O2 sensor, and components necessary to install it on your intake manifold. The Royal Flush is designed to fit any 4150 flange 4-barrel intake manifold, easy to use and install, and includes a high resolution, full color handheld controller with 5-inch touchscreen for tuning and monitoring. ROYAL FLUSH includes:

- 32-bit Power Architecture® based MCU for automotive powertrain applications
- Throttle Body designed to fit a 4150-style flange intake manifold
- Reliable external mount ecu/integrated CDI ignition
- Supports up to 650hp with Four 100 Lb/Hr Injectors
- Integrated Digital CDI with 220 mj spark energy output
- 2-stage Rev limiter setting for maximum RPM
- 2-stage Rev limiter setting for Launch control and burn out
- Step retard for Nitrous control
- RPM range 15000/10000RPM at full power
- Boost application with 3bar TMAP sensor, TPS, and IAC.
- Bosch 4.9 Wide band O2 sensor
- External fuel pump relay
- Dual fan control
- 5 inch High Resolution Full Color Touchscreen for Initial Setup, Tuning, and Gauge Displays
- Simple Calibration Wizard - No laptop required.
- High Fidelity Lap Top Tuning Software Included
- Self-tuning ECU means you don't have to be a computer/tuning wiz to have EFI.
- CAN communication for Handheld calibration and display
- Available ACES CAN module adds inputs and outputs for aftermarket digital displays
- Available finishes: black ceramic, polished
- Available in base and master kits (master kits include complete fuel system: 20 ft. of fuel hose, fuel pump, filter/regulator, necessary hardware, and bulkhead fitting for returning fuel to tank)
- Available finishes: black ceramic, classic gold, and shiny
- Choose from Base or Master Kits (Master Kits includes complete fuel system: 20 ft. of Earl's Vapor Guard fuel hose; fuel pump; filters; necessary hardware, and bulkhead fitting for returning fuel to tank)

Thank you for betting on ACES! We are proud to be your manufacturer of choice.

Parts List

| Item | Description | QTY | Service Part |
|------|---------------------------------|-----|--------------|
| 1 | ROYAL FLUSH™ ECU | 1 | AH2014 |
| 2 | Handheld | 1 | AS2009 |
| 3 | Throttle Body Assembly | 1 | AM1001 |
| 4 | Main harness | 1 | AH2014 |
| 5 | Wide band O ₂ sensor | 1 | AE1060 |
| 6 | Coolant Temperature Sensor | 1 | AE1052 |
| 7 | Clamp-on Oxygen Sensor Bung | 1 | AE1061 |
| 8 | Air Cleaner Gasket | 1 | |
| 9 | 4150 Flange Gasket | 1 | |
| 10 | Breather Stud | 1 | |
| 11 | 2" Grommet | 1 | |

ADVANCED USER CAPABILITIES

The ACES ROYAL FLUSH™ EFI software does allow for advanced tuning functionality. A laptop is required to access the advance tuning functions. These functions are not recommended for enthusiasts without extensive EFI tuning knowledge and experience.

NOTE: Making changes to the calibration in the advanced tuning functions can lead to catastrophic engine damage if not done correctly. ACES is not responsible for any damage caused due to advanced tuning errors.

WARNINGS, NOTES, AND NOTICES

NOTE: This system does not contain fuel system components including the fuel pump, fuel filters, fuel pressure regulator, and lines. ACES fuel injection offers complete kits which can be purchased separately (coming soon!).

NOTE: This system is designed for stock and mild cam, naturally aspirated, boosted (draw through), and nitrous oxide applications.

WARNING! The ROYAL FLUSH™ TBI systems consist of several sophisticated components. The failure of any one component does not constitute, nor does it justify, warranty replacement of the complete system. Individual service items are available for replacement of components.

WARNING! To preserve the warranty, these instructions must be read and followed thoroughly and completely before and during installation. It is important that you become familiar with the parts and the installation of the ROYAL FLUSH™ TBI system before you begin. Failure to read and understand these instructions could result in damage to ROYAL FLUSH™ TBI components that are not covered by the warranty and could result in serious personal injury and property damage.

WARNING! The oxygen sensors in this kit are recommended for use with unleaded fuel ONLY. Use of leaded fuels will degrade the oxygen sensor and will result in incorrect exhaust gas oxygen readings and improper fuel delivery. Failure to follow these directions does not constitute the right to a warranty claim.

WARNING! Failure to follow these instructions will result in an improper installation, which may lead to personal injury, including death, and/or property damage. Improper installation and/or use of this or any ACES product will void all warranties.

WARNING! Use of some RTV silicone sealers will destroy the oxygen sensors used with this kit. Ensure the RTV silicone sealant you use is compatible with oxygen sensor vehicles. This information should be found on the RTV package.

WARNING! For the safety and protection of you and others, only a trained mechanic having adequate fuel system experience should perform the installation, adjustment, and repair. It is particularly important to remember one of the basic principles of safety: fuel vapors are heavier than air and tend to collect in low places where an explosive fuel/air mixture may be ignited by any spark or flame resulting in property damage, personal injury, and/or death. Extreme caution must be exercised to prevent spillage and thus eliminate the formation of such fuel vapors.

WARNING! This type of work **MUST** be performed in a well-ventilated area. Do not smoke or have an open flame present near gasoline vapors or an explosion may result.

WARNING! This installation is not for the tuning novice! Use this system with **EXTREME** caution! The ACES ROYAL FLUSH™ EMS allows for total flexibility in engine tuning. Misuse or improper tuning of this product can destroy your engine! If you are not well versed in engine dynamics and the tuning of engine management systems **DO NOT** attempt the installation. Refer the installation to an ACES-trained tuning shop or call ACES for technical assistance.

NOTE: All supplied ACES FUEL INJECTION calibrations, wizards and other tuning information are offered as potential starting points only. **IT IS THE RESPONSIBILITY OF THE ENGINE TUNER TO ULTIMATELY CONFIRM IF THE CALIBRATION IS SAFE FOR ITS INTENDED USE.** ACES FUEL INJECTION holds no responsibility for any engine damage that results from the misuse or mistuning of this product!

1.0 Introduction and System Requirements

This manual has been written by ACES Fuel Injection for the installation of the Royal Flush EFI throttle body injection system. This basic manual contains the information necessary for the installation of the throttle body, wiring, and sensors. Please read all the WARNINGS and NOTES, as they contain valuable information that can save you time and money.

WARNING! Before disconnecting the battery, we recommend locating a clean switched 12-volt ignition source. This source needs to have 12 volts while cranking and with the key in the run position. Disconnect battery before proceeding with any work to the vehicle.

NOTE: An assistant is necessary for some installation and adjustment procedures and should be present for safety reasons.

1.1 Engine Requirements

Before the installation, please verify your vehicle meets the engine and fuel system requirements below:

- Engine is in sound mechanical condition
- Engine horsepower is between 200-650
- Engine is a 4-, 6-, or 8-cylinder
- Engine has a 4-barrel, 4150-style flange intake manifold
- Unleaded fuel only
- Any RTV silicone sealants used on the engine are sensor safe

NOTE: Any 4150-flange intake manifold will work. Make sure to use proper gaskets to seal the throttle body to the intake manifold and ensure that there are no vacuum leaks.

2.0 Installation

2.1 Throttle Body Installation

The throttle body has two connectors: one to control TPS and the other to control fuel injectors, IAC, and TMAP sensor.

The ACES throttle body design not only makes the throttle body structure clean and easy to install, but also the fuel injection controller is located externally. It is not affected by the high temperature and vibration of the engine, ensuring durability, reliability, and consistent performance.

NOTE: If you will be installing a new distributor, such as the ACES fuel injection BLACKJACK™ Pro Distributor, you may have more room to work if you complete the first part of that installation before bolting down the throttle body.

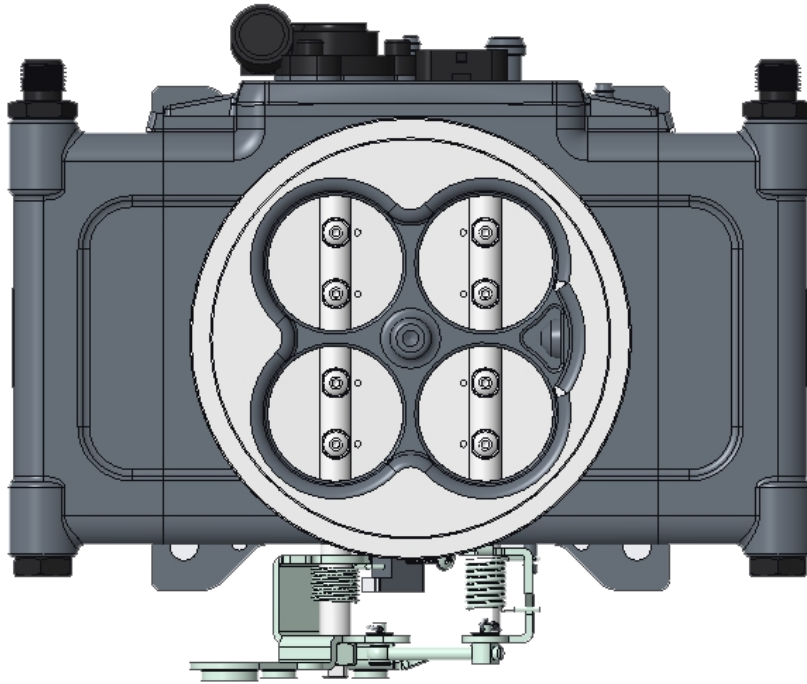

Throttle Body Aerial View

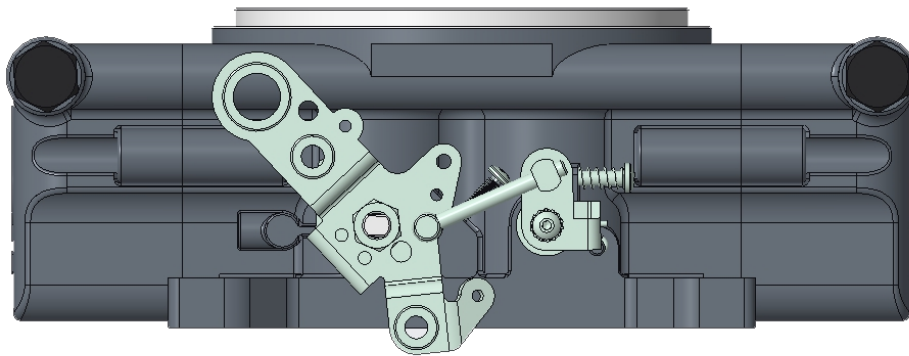

Throttle Body Side View

1) Begin by removing your carburetor. As you remove the carburetor, note which vacuum lines are running to ported or manifold vacuum. Determining if a vacuum port is “ported” or “manifold” vacuum varies on each carburetor; refer to the manufacturer’s specs for your specific carburetor.

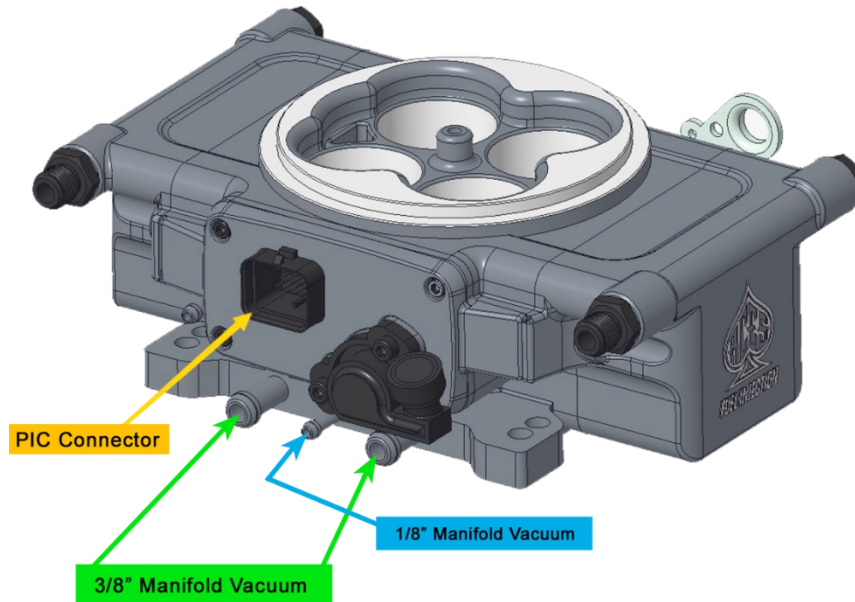

NOTE: If you will have the carburetor removed for a length of time, be sure to plug your manifold with clean rags so that no foreign debris is allowed to enter the engine.

2) Install your new ROYAL FLUSH™ throttle body using the provided gasket and fasten using the screws or studs that were used for your carburetor.

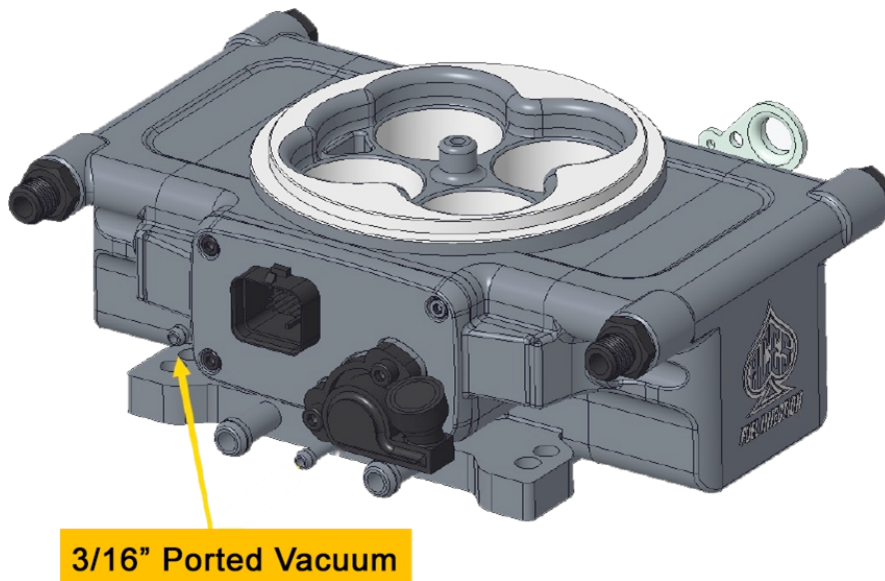

3) Reconnect all vacuum hoses, being sure to connect any ported vacuum systems to the correct 3/16" port as shown above. Leave any unused ports capped with the provided rubber caps.

4) When your entire installation is finished, be sure to install an air cleaner onto your throttle body.

2.2 Fuel System

A complete high pressure EFI fuel system must be installed for the ROYAL FLUSH™ EFI system. The ROYAL FLUSH™ EFI system requires a minimum of 42-48 psi to operate, and it can be used with a return or returnless fuel system. When selecting a pump, regulator, and lines, be sure each component is designed to perform at high pressure. Coming soon, ACES Fuel Injection will offer Master Kits which include a fuel pump, hose, and accessories to complete your installation. The following are some guidelines to help set up a fuel system for your ROYAL FLUSH™ EFI system as well as components available separately from ACES Fuel Injection. If using an in-line fuel pump, there should be a coarse pre-filter before the pump.

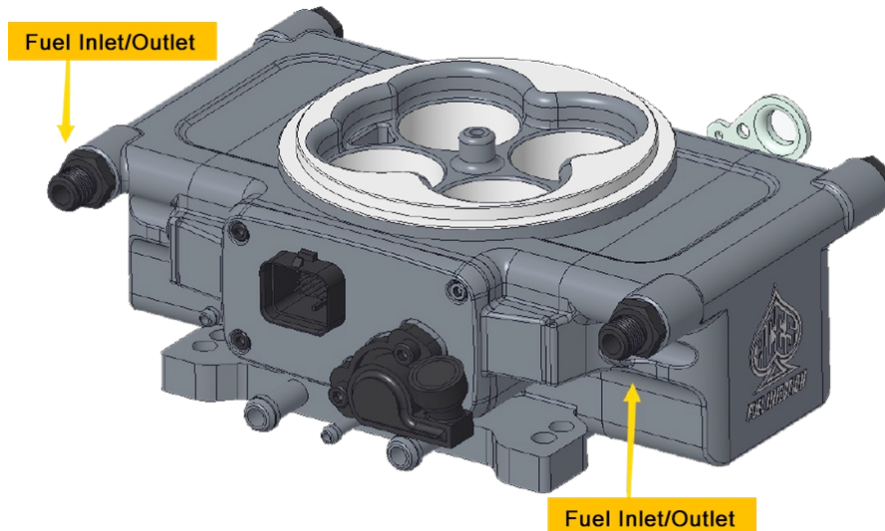

All systems should contain a 10-micron post-fuel filter after the fuel pump. An EFI-rated high-pressure, vacuum-referenced, bypass fuel pressure regulator is required.

The fuel pump **MUST** be mounted lower than the lowest part of the fuel tank, and as close to the tank as possible. The fuel tank must also be properly vented.

- 1) Use the following diagram as a reference for the orientation and location of the fuel system components
- 2) Mount the electric fuel pump as close to the fuel tank outlet as possible with the bracket provided. Mounting the fuel pump in this manner will ensure that the pump will prime easily to ensure faster starts.
- 3) The pre-filter **MUST** be installed between the fuel tank and the fuel pump inlet. The purpose of this filter is to protect the fuel pump from particles of dirt or other foreign material. The filter should be installed with the arrow on the filter pointing in the direction of the fuel flow.
- 4) The post-fuel filter should be installed between the electric pump outlet and TBI unit and should be a 10-micron EFI filter. Position the filter so the fuel hoses can be routed without kinks or sharp bends. The filter should be installed with the arrow on the filter pointing in the direction of the fuel flow.

WARNING! Ensure both filters are installed in the proper direction. A flow direction arrow is printed on the side of the filter to indicate the direction of fuel flow. Failure to do so will result in a system malfunction.

Some late model vehicles that were originally equipped with a throttle body injection system may already have a return line to the fuel tank that can be utilized. The return line must not present a pressure restriction to the return fuel flow.

There should never be more than approximately 3 PSI of pressure in the return line. A line that is too small or has restrictions will cause tuning problems with the system.

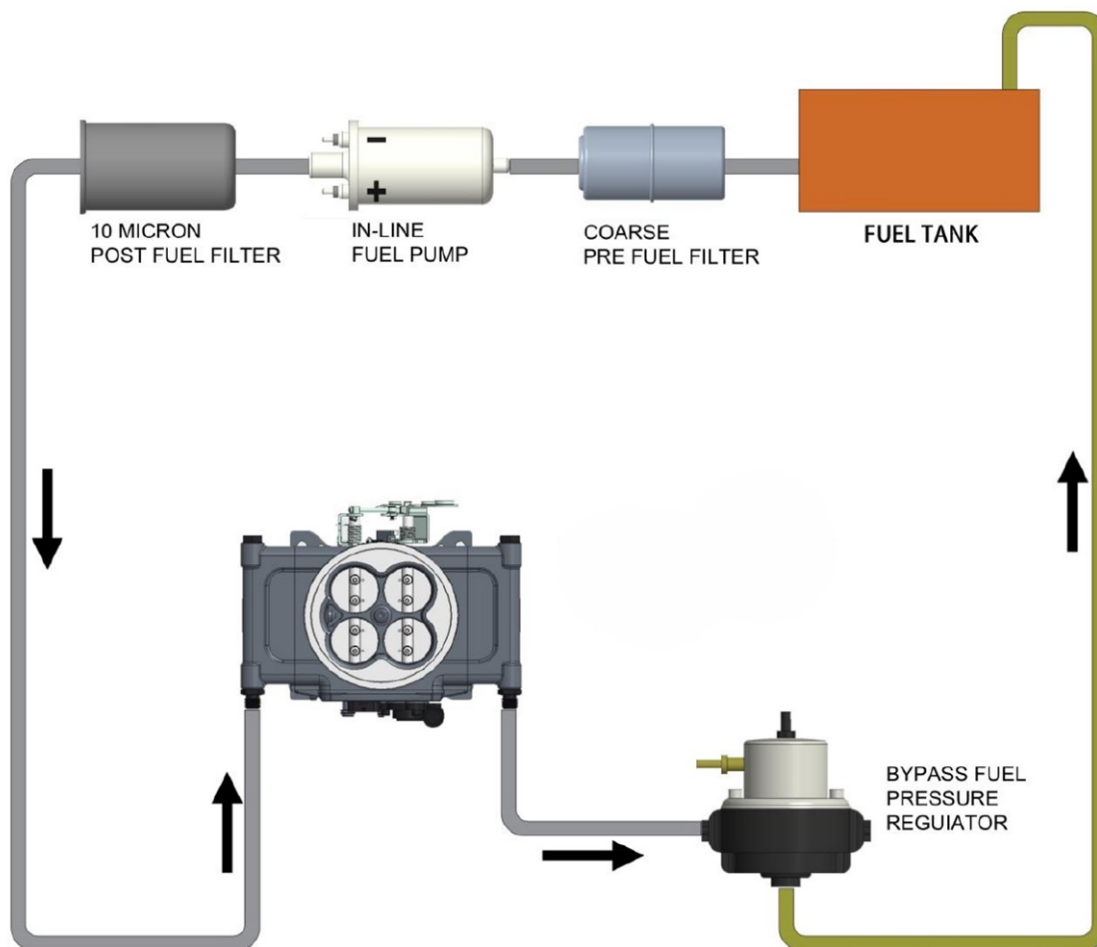

DANGER! Do not use the vapor canister lines as a fuel return line. Possible fuel leaks may create a fire or explosion hazard, potentially causing serious injury or death.

DANGER! Proper installation of a fuel return line, if indicated, may necessitate complete removal of the fuel tank. This work should be done by a fuel tank specialist, who regularly does this work and is familiar with safety regulations and precautions necessary to do this work. If a person attempts this work, who is not familiar with the safety regulations and precautions, an explosion may result causing serious injury or death.

2.3 Oxygen Sensor Installation

IMPORTANT! Position and support your vehicle on a suitable surface. USE CAUTION AND WORK ONLY ON A LEVEL SURFACE USING JACKS AND JACK STANDS OF SUFFICIENT CAPACITY TO LIFT AND SUPPORT YOUR VEHICLE. NEVER WORK UNDER A VEHICLE SUPPORTED BY A FLOOR OR BUMPER JACK. Use of a two-post underarm lift or four-post drive-on lift will considerably reduce the time and effort required to complete the installation. MAKE SURE LIFT LOCKS ARE ENGAGED BEFORE WORKING UNDER THE VEHICLE.

WARNING! Failure to disconnect the AIR pump and/or locating the oxygen sensor downstream from AIR injection will result in an extremely rich mixture, which could cause drivability problems and severe engine damage. If disconnecting

the AIR pump, check with local ordinances for the legality of this procedure in your area.

1) Locate a position for the oxygen sensor as close to the engine as possible. The oxygen sensor should be mounted at a point where it can read a good average of all the cylinders on one bank. This would be slightly after all the cylinders merges. If you have long tube headers, mount the sensor approximately 1-10" after the collector. You must have at least 18" of exhaust pipe after the sensor. If your vehicle has catalytic converters, the oxygen sensor MUST be located between the engine and the catalytic converters.

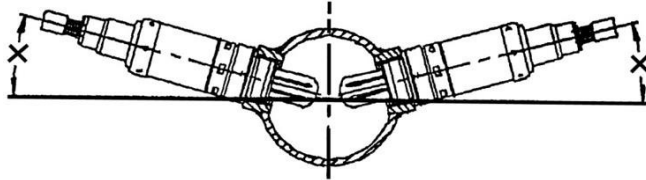

2) Ensure the sensor is located at the approximate angle shown above. This will help prevent condensation in the exhaust tubing from entering the sensor. The sensor can be mounted on either side of the tubing.

3) Drill a 7/8" hole in the intended location for the sensor. Weld an oxygen sensor weld ring into the 7/8" hole or use the clamp on bung system included. Weld all the way around the bung to insure a leak-proof connection. Allow the bung to cool completely, install the oxygen sensor into the weld ring, and tighten securely. It is a good idea to add anti-seize to the threads to aid in removal. Do not get any anti-seize on the tip of the sensor.

NOTE: Never run the engine with the oxygen sensor installed if it is not plugged in and powered by the ECU, or it will be damaged. If you need to plug the hole temporarily, use an O₂ sensor plug, or a spark plug with an 18mm thread.

2.4 Coolant Temperature Sensor Installation

Install the coolant temperature sensor into a 3/8" NPT coolant passage in either the intake manifold or cylinder head. Do not overtighten or damage to the cylinder head or intake may occur. It is best to drain some of the coolant before the sensor is installed. Use thread sealer or a small amount of thread tape. Do not install the sensor in the thermostat housing, or in an area that will not see a constant flow of coolant.



Coolant Temperature Sensor

2.5 Boost Reference Port

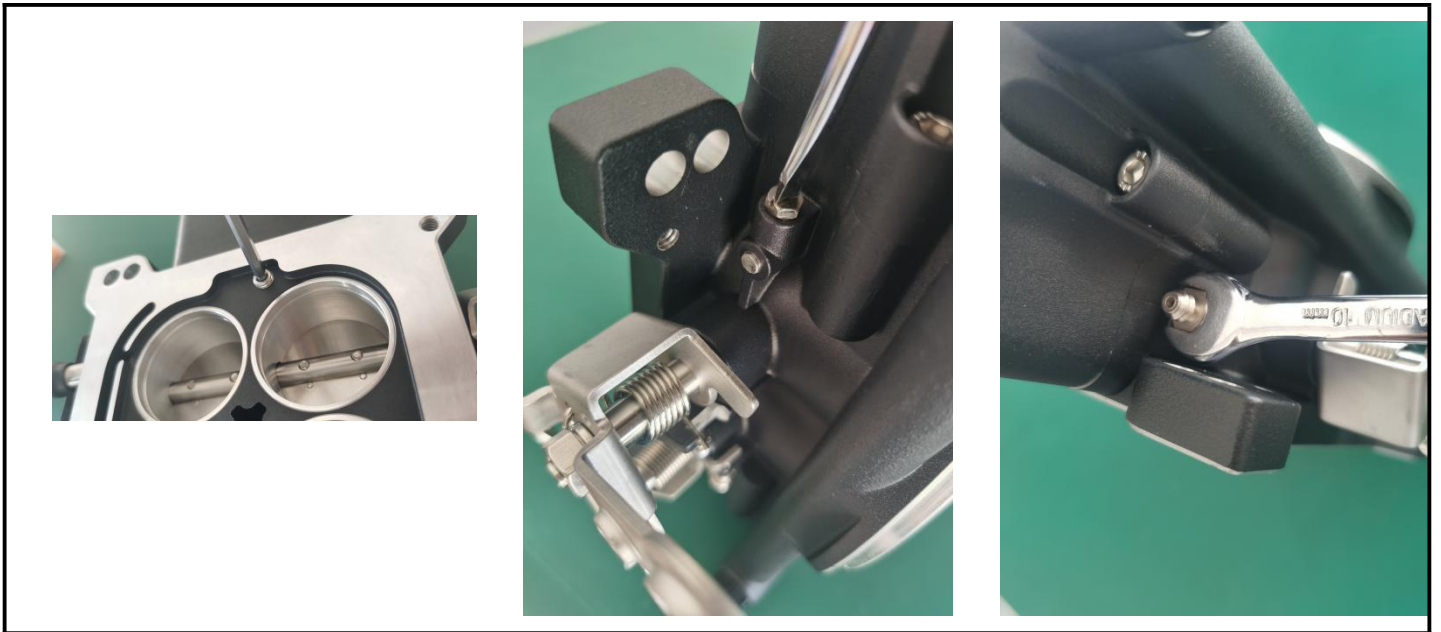

Turn the throttle body upside down. Using a small drop of Loctite on the plug, install the plug into the threaded orifice next to the throttle blades.

Locate the boost reference port on the throttle body. It is located on the lower right corner of the throttle body on the same side as throttle cable linkage and remove the plug.

Install A 1/16" pipe-to-hose fitting into the boost reference port on the throttle body.

The boost reference port on the throttle body should be referenced below the supercharger directly from the manifold or can be split off the boost gauge reference line.

3.0 ECU Mounting and Wiring Overview

The ROYAL FLUSH™ ECU can be mounted inside the passenger compartment (preferable location) or in the engine compartment. If mounted in the engine compartment, follow these guidelines:

- Mounting location should be as far from exhaust manifolds or headers as possible.
- Mount it as far away from spark plug wires, CD ignition boxes, or other “electrically noisy” devices as possible.
- Install vibration mounts. These vibration mounts are just the thing to help isolate severe racing vibrations and keep the controller at a distance from the mounting surface for heat dissipation.
- An EFI system depends heavily on being supplied a clean, constant voltage source. The grounds of an electrical system are just as important as the power side.

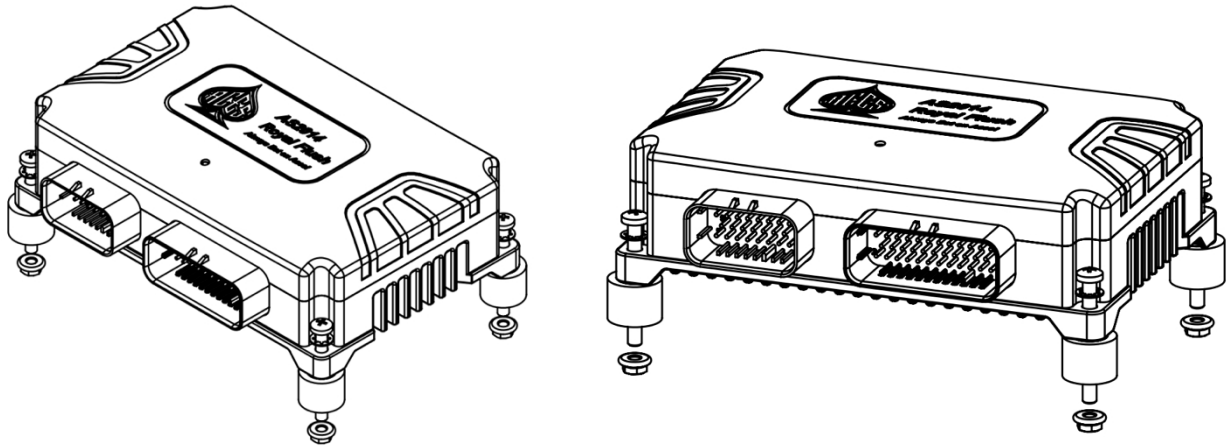

ROYAL FLUSH™ ECU's contain multiple processing devices that require clean power and ground sources. The wiring harnesses for them must be installed in such a manner that they are separated from "dirty" power and ground sources.

Keep sensor wiring away from high voltage or "noisy/dirty" components and wiring, especially secondary ignition wiring (plug wires) and associated wiring. It is best that the plug wires not physically contact any EFI wires. NEVER run high voltage or "noisy/dirty" wires in parallel (bundle/loom together) with any EFI sensor wiring. If wires need to cross, try to do so at an angle.

The main power and ground source must be connected directly to the positive and negative battery terminals, not to any other place.

Properly crimp and solder any wire connections. Apply quality heat shrink over any of these connections.

It is critical that the engine has a proper ground connection to the battery and chassis.

Do not use the electric fan outputs to directly power fans. They must only be used as a trigger source for a properly sized relay for the specific fan(s) used.

Don't use things like t-taps, etc. Use proper crimp connectors/solder and heat shrink.

It is never recommended to splice/share signal wires (such as TPS, etc.) between different electronic control units (i.e., "piggyback").

3.1 ECU Wiring Overview

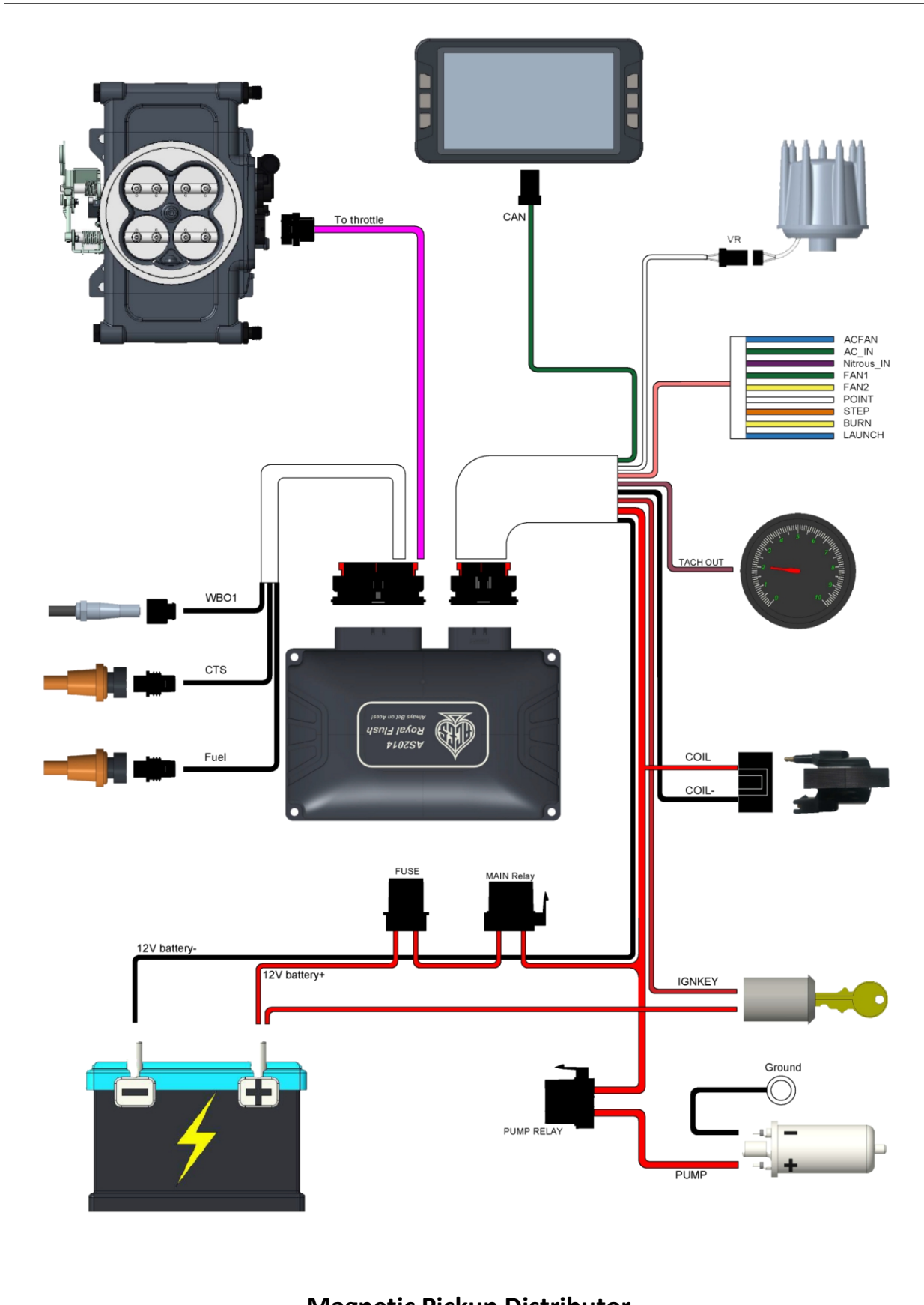

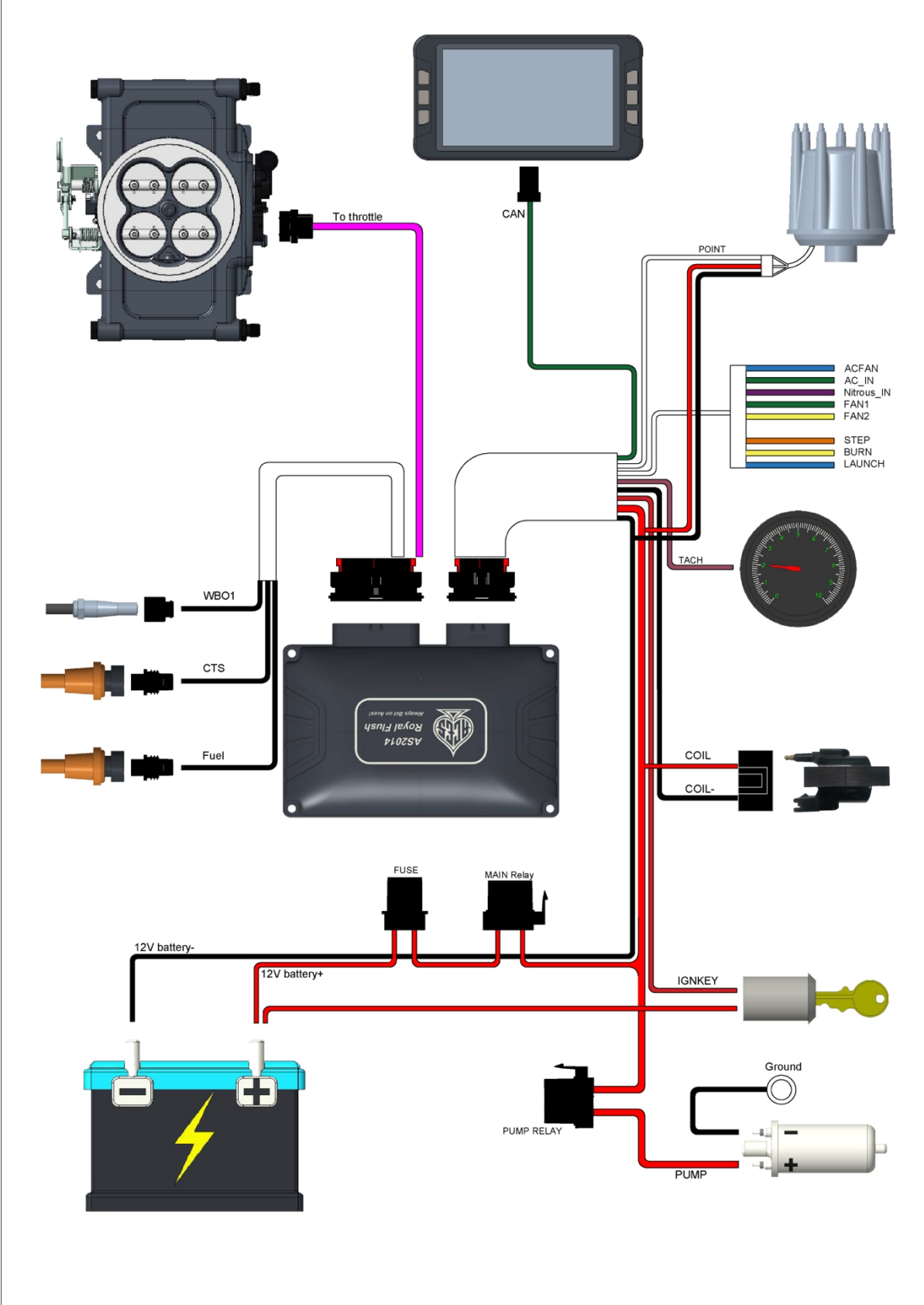

Distributor with Hall Effect Crank Signal Sensor

4.0 Wiring Installation

4.1 Harness Routing

If the ECU is mounted in the interior, the harness will have to be routed through the firewall into the engine compartment. Use a 2" hole saw to create a hole in a desired location if no other point of access is available and use the 2" grommet included to seal this area.

If the ECU is mounted in the engine compartment, the handheld tuning module cable will have to be routed to the "CAN" connector on the main harness (located near the ECU connector main connector). This is assuming you want to access the handheld module after startup. This will require routing the small CAN connector somewhere through the firewall.

Connect the PIA and PIB connectors of the main harness into the ECU.

About 22" from the ECU main connectors is a 40A relay. This powers the injectors and wideband O₂ sensor heating. There is also a fuel pump relay to control the fuel pump.

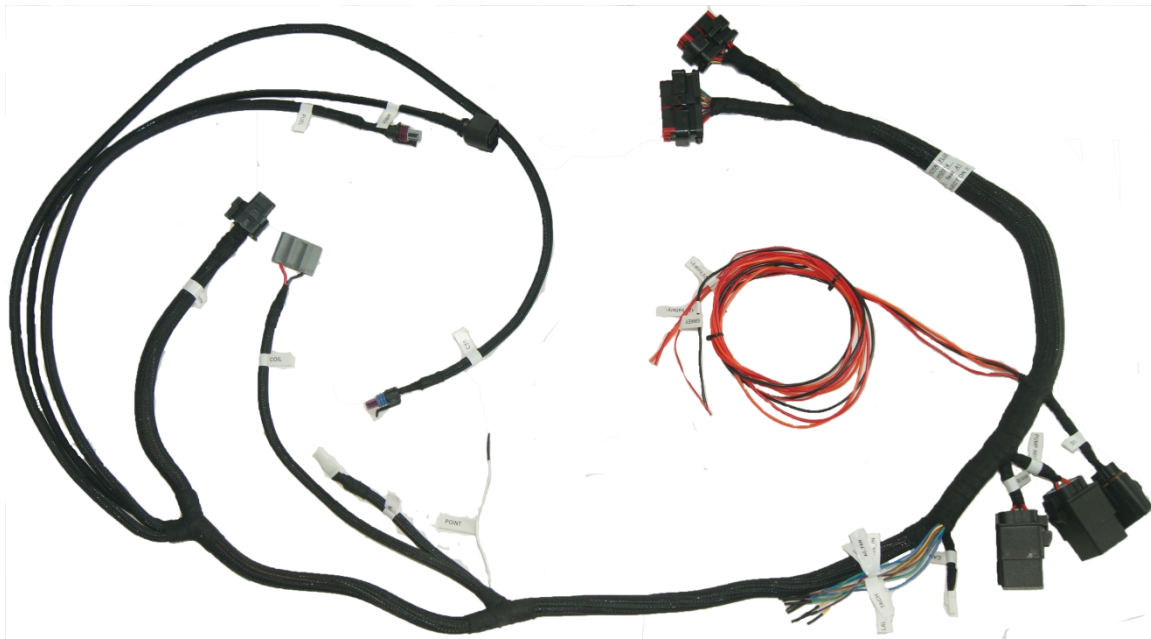

4.2 Sensor Connection

Connect the bulkhead, CTS, WBO₂, CAN, and throttle body connectors (PIC) to their dedicated sensors/connectors in the diagram.

The throttle body connector (PIC) integrates the injectors, TMAP, TPS, and IAC wires. Plug this PIC connector into the corresponding connector on the throttle body.

Connect the distributor coil connectors (if using ROYAL FLUSH™ ignition control).



Throttle Body Connector (PIC)

4.3 Ignition Coil (With Timing Control)

The ROYAL FLUSH™ ECU integrates an ignition coil driver that uses a high performance IGBT chip. ACES recommends using ACES BLACKJACK Pro Series Ignition Coil (PN AC2008) to get 90mj with 3ms dwell time spark energy without a CDI box. It is beneficial to cold start, maintaining idling stability and improved fuel economy.

Connect coil connector to ignition coil AC2008 if you set harness connection and ECU configuration with timing control.



Ignition Coil Connector

- Primary Resistance: 0.273Ω
- Primary Inductance: 2.63 MHz
- Secondary Resistance: 3.42 kΩ
- Secondary Inductance: 15.77 Hz
- Output (50pF load): 47 kV
- Output Energy: 150 mJ
- Peak Secondary Current: 100 mA +/- 7%
- Arc Duration: 200 μS
- Turns Ratio 78:1



AC2008 BLACKJACK Pro Ignition Coil

4.4 Loose Wires

The following loose wires in the main wiring harness should be connected as follows on all systems. These wires come out of the harness about 18" from the ECU connectors:

IGNKEY (Red) Should be connected to a clean +12-volt power source. Power source should only be active when the ignition is on. Make sure source has power when engine is cranking as well (check with voltmeter). Not all sources apply power when the ignition switch is in "cranking" position. DO NOT connect to a "dirty" source like an ignition coil.

12V Battery+ (Red) Should be connected directly to the positive terminal of the battery. This powers the fuel pump and fuel injectors. This wire is protected by a fuse in a sealed fuse holder. The fuse holder is located about 18" from the ECU connector. A fuse is pre-installed (20A).

12V Battery- (Black) Connect to a chassis ground point that has excellent connectivity with both the engine and battery. There must be good continuity between the connection point and the battery when checked with a digital volt ohm meter (DVOM). This ground should not be connected at the same location as other grounds. This wire is located approximately 18" from the ECU connectors.

Pump+(Orange) Used to activate a fuel pump (+12 volt). Do not use this wire to power fuel pumps that require over 15 Amps. Refer to your fuel pump manufacturer for amperage ratings. For high current pumps, use this wire to trigger a separate relay and use larger gauge wire to feed the pump; we recommend 10 gauge. The fuel pump also requires a ground wire. Run a wire from the negative side of the fuel pump. Connect it to a solid chassis/frame ground.

4.5 Additional Wires

The following additional wire outputs in the main wiring harness should be connected as follows on all systems. These wires come out of the harness about 23" from the ECU connectors except **Point**.

Tach Out (Color = Grey) This wire provides a 12v square wave output and can be used to trigger a conventional tachometer.

Point (Color = White) A Tach output from billet distributor with Hall effect crank signal sensor like Holley Sniper distributor.

Fan1 (Color = Green) This output will provide a ground output to trigger a relay used for a cooling fan. This output should never be directly connected to a fan, but the relay that powers the fan. It should be connected to the ground trigger of the relay.

Fan2 (Color = Yellow) This output will provide a ground output to trigger a relay used for a cooling fan. This output should never be directly connected to a fan, but the relay that powers the fan. It should be connected to the ground trigger of the relay.

Nitrous_IN (Color = Purple) Nitrous activation wire. Feeding 12 V power to this wire tells the ECU that a nitrous oxide system has been activated.

Burn (Color = Yellow) Burn out Rev Limiter, feeding 12 V power to this wire tells the ECU that a burn out control has been activated.

Launch (Color = Blue) Launch Rev Limiter, feeding 12 V power to this wire tells the ECU that a Launch control has been activated.

Step (Color = Brown) Step Retard, feeding 12 V power to this wire tells the ECU that a step retard has been activated.

AC_IN (Color = Green) This 12V input will provide a 12V input defined AC is on.

REV (Color = Blue) Optional - Programmable ground output

5.0 Handheld Controller

The Handheld Controller is used to create an initial calibration for the system, allows for simple tuning changes to be performed, and is also used to view various real-time EFI system data. We recommend that it be installed in the passenger compartment. The handheld plugs directly into the main harness at the connector labeled "CAN". This connector is located approximately 23" from the ECU connector. The handheld does not have to remain in the vehicle or be connected to the system once the vehicle is set up and running properly. (See Handheld controller section for more information)

6.0 Ignition Wiring

Royal Flush is the latest EFI innovation by integrating with EFI control module and a CDI ignition system in one ECU, so based on such design, Royal Flush can work with most common magnetic pickup distributors like ACES Blackjack series or most aftermarket billet distributors with hall-effect crank signal sensors. It is not recommended to be used with ready-to-run HEI distributors, or GM large gap distributor.

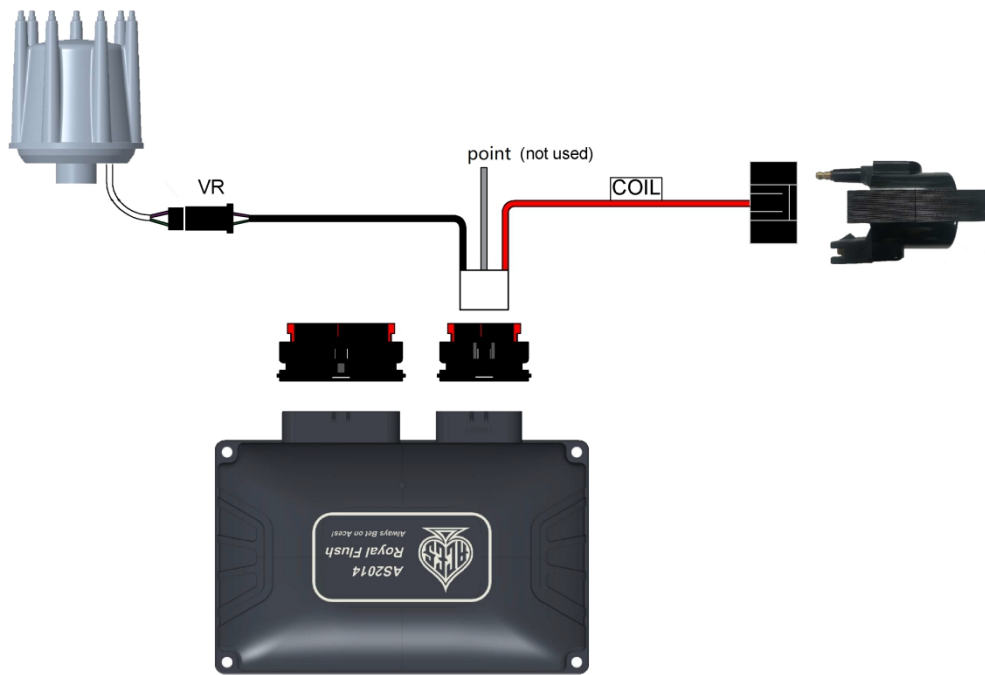

OR

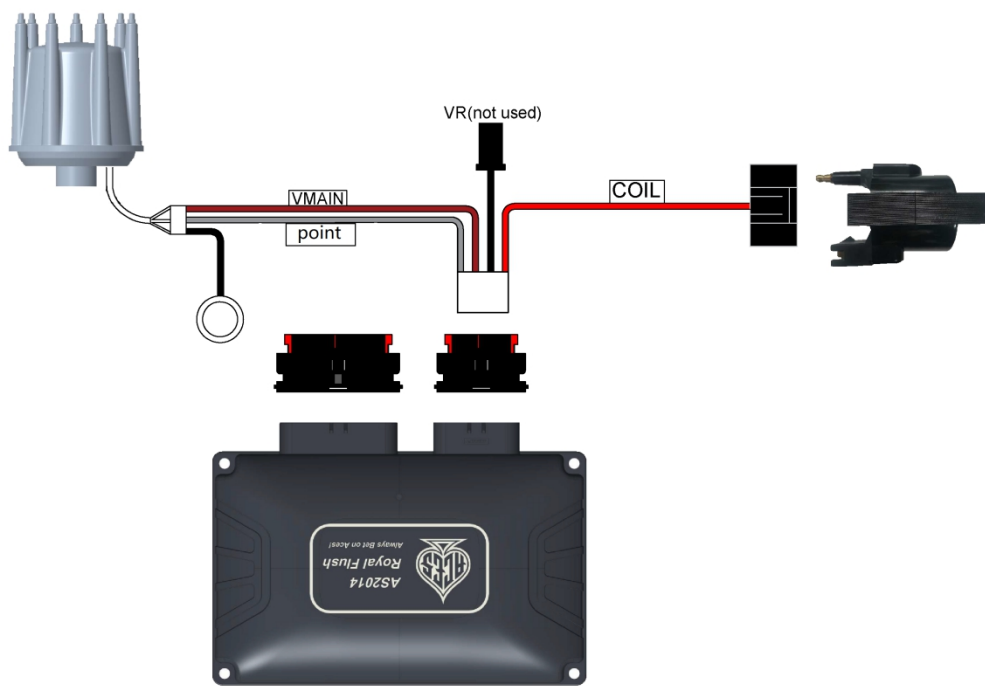

6.1 No Timing Control

Royal Flush ECU will get its RPM signal from the magnetic pickup distributors and Hall effect crank signal distributor then the CDI driver circuit on the royal flush will drive and charge the ignition coil.

In no timing control state, please make sure the following items are set correctly

Select *NO* of Timing Control in Wizard or Set *Lock Ignition Timing* to “lock.”

Install your distributor at top dead center of cylinder 1#.

Static Timing is set to 0.

Distributor is unlocked, ignition timing is determined by your distributor or other module.

6.2 Timing Control

Royal Flush EFI can control timing using most common magnetic pickup distributors like ACES blackjack series and billet distributor with Hall effect crank signal sensor like Holley Sniper distributor. However, you may need to make several very simple changes to the distributor which are outlined in the following section. It is very important that you “lock out” the advance built into the distributor and install an adjustable rotor. Not “locking out” the distributor and installing an adjustable rotor as outlined in these instructions can cause the engine to run poorly or even cause engine damage.

ACES recommends that those who wish to use the Royal Flush timing control feature first get the engine to run without timing control. Splitting the timing control into a secondary process will add very little time to the total install, but could significantly help with trouble shooting, should it be needed.

In timing control state, please make sure the following items are set correctly

Select *YES* of Timing Control in Wizard or Set *Lock Ignition Timing* to “unlock.”

Install your distributor into engine at 15 degrees BTDC of cylinder 1#

Static Timing is set to 15 degrees BTDC

Distributor is locked out; ignition timing is determined by your Royal Flush pre-setting.

The following are a list of items that are required to use the timing features of the Royal Flush EFI system:

The distributor must be locked-out

An adjustable rotor is required to achieve accurate rotor phasing. For standard GM size MSD distributors, use rotor PN 84211. For larger, Ford style MSD distributors it is recommended to fit the distributor with a smaller cap (PN 8433) and the PN 84211 rotor. If the larger cap must be used, try rotor PN 8421.



Phase Rotor

It is recommended but not required to use an ACES BLACKJACK Pro Series Billet Distributor with a 2-pin mag pickup connector.

The balancer must be degreed. Mark on the balancer at 15 degrees before top dead center (BTDC).

Follow this procedure:

Start by locking out the centrifugal advance on your distributor. The distributor must be physically “locked out” so that the relationship between the pickup and the paddle wheel does not change with engine speed or load. Refer to the manufacturer’s instructions for the proper procedure to lock out the centrifugal advance for your distributor. (This is a very important step; please do not skip.)

Once your distributor is locked out, position the engine at 15 degrees before top dead center (BTDC).

Insert your distributor into the engine but do not clamp it down yet.

Rotate the distributor body so that the pickup is aligned with the closest paddle on the paddle wheel. It is important for this paddle to be as centered as possible. (There will be an opportunity to check the alignment and compensate for any misalignment with the Handheld later in this installation procedure.)

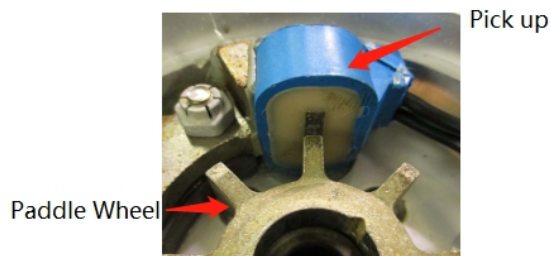

Clamp down the distributor.

It is important to phase the rotor to the cap. This will ensure that the rotor is in the correct position throughout the timing sweep to fire to the correct cylinder terminal. If the rotor is not properly phased, then during operation, the

rotor tip can sweep too far away from the correct terminal causing a weak spark or misfire and a lot of electrical noise. To correctly phase your distributor, you will need a phasable rotor (such as MSD PN 84211) if you do not already have one.

Install the phasable rotor bottom and loosely install the rotor top.

Set the cap on the distributor and mark the middle of the #1 terminal on the distributor body.

Remove the cap and adjust the phasable part of the rotor until the center of the rotor tip is lined up with the center of the mark you made. Then tighten the rotor adjuster screw and install the cap.

★ Timing Offset

Use this value to retard or advance the timing or sync timing at higher RPMs. These values are sett to 0 in the base calibrations. Some ignition modules may need this number altered if the commanded timing does not match the commanded timing as engine speed increases. If the timing starts to retard as rpm increases, this number can be increased in order for the timing to match.

8.0 Handheld Controller Navigation and Use

The Aces EFI ROYAL FLUSH™ Handheld Programmer utilizes a 5" capacitive touchscreen and six manual buttons. The LCD screen has a large, vividly colored display. The Handheld uses CAN bus communication to the ECU and has a type-C USB interface for programming and other operations. All operations are done by touching the screen or the manual buttons.

The handheld can be used for monitoring and calibrating the system (for example: idle speeds, AFR targets, fuel pump, etc.) after connecting it with the ECU. It is portable and convenient for tuning at any time.

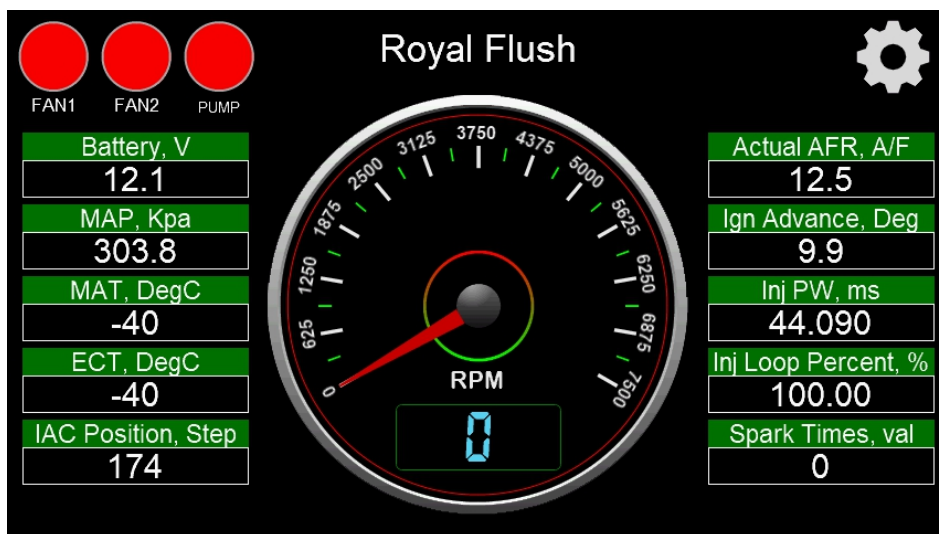

8.1 Making Adjustments

1) Slider Bar: Slide the bar or click "<" and ">" to adjust the parameters, click "Save" to save, and click "Cancel" to cancel.

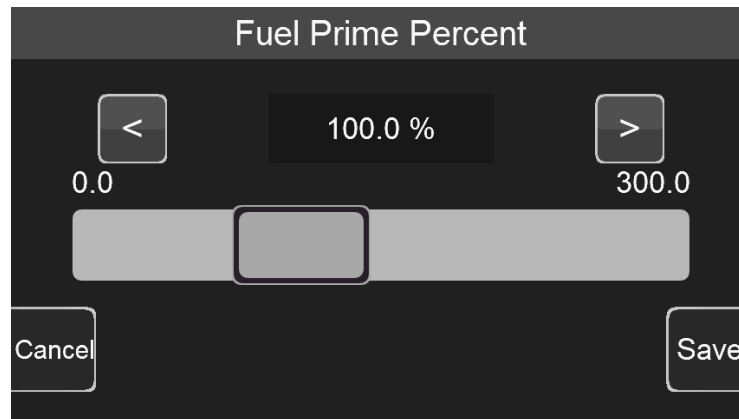

2) Numeric keyboard: Click the edit box "100.0%" above the sliding bar to pop up the numeric keyboard.

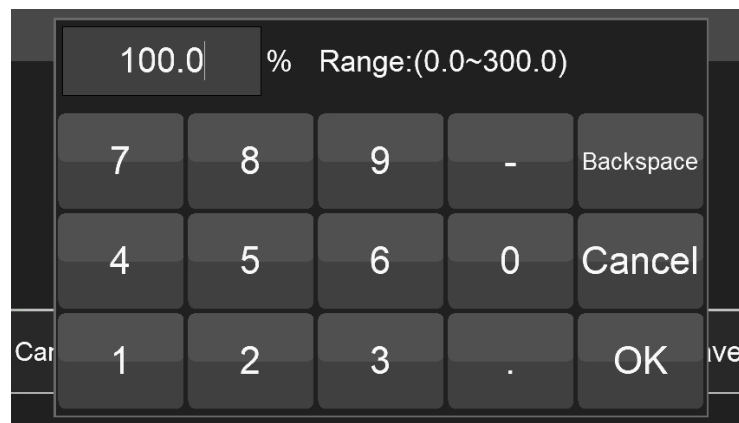

3) 2D Graph: Drag the red dot on the graph or click the mechanical button on the left to adjust the parameters. When adjusting the parameters, the upper right corner will display the Y-axis coordinate value of the currently adjusted parameter. The three buttons on the left side of the interface will disappear after a short display. Click the mechanical button on the lower left corner to switch the position of the small yellow dot, click the middle button on the left to lower the yellow dot, and click the mechanical button in the upper left corner to raise the yellow dot. The Y-axis coordinate value of the yellow dot is displayed in the upper right corner of the interface.

After the configuration is complete, click "Save" to download the calibration data to the ECU; click "Cancel" to cancel the modification.

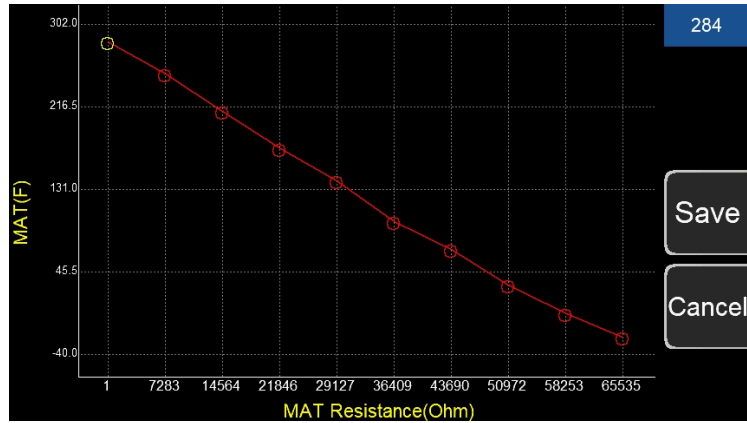
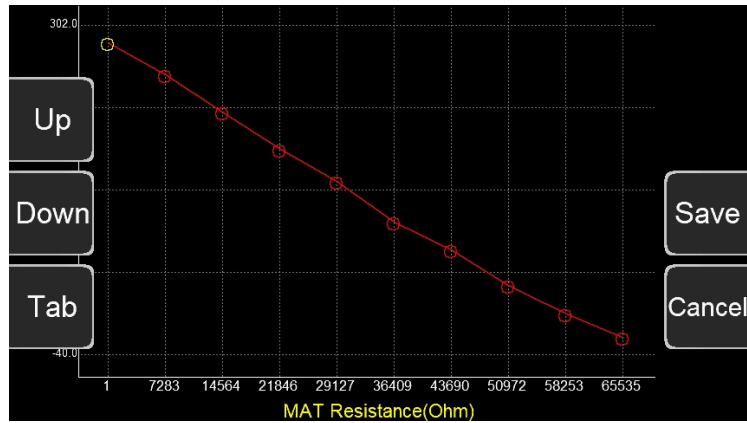

8.2 Connection

The handheld is connected to the ECU through the CAN bus. Program upgrading can be done through the type-C USB interface.

8.3 Navigation buttons

The ACES Handheld is designed for reliable operation and use. There are buttons on both sides of the display. The handheld is operated by touching the screen or the buttons on the sides. (See figure on the next page.)

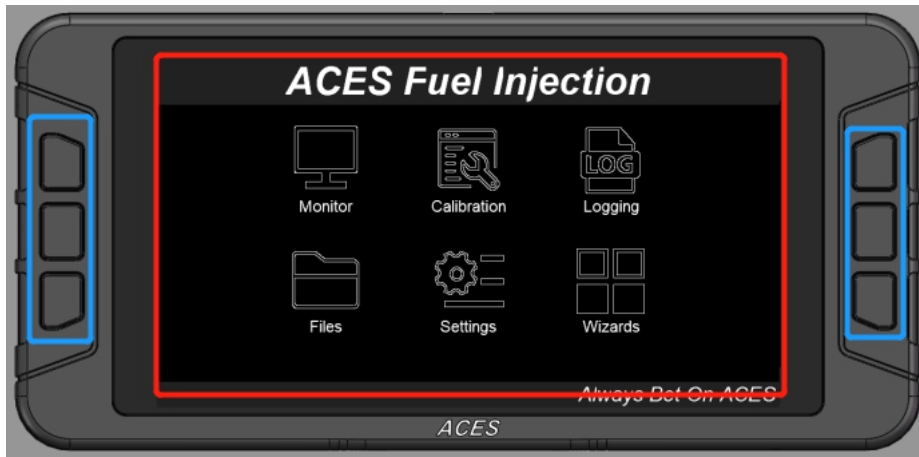

8.4 Main Menu

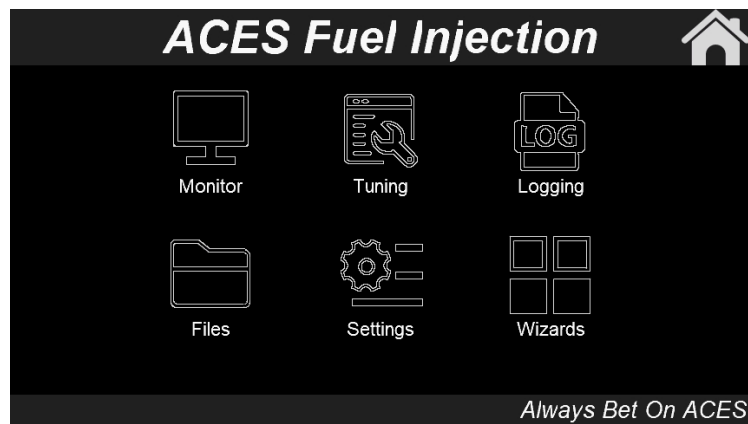

The Main Menu has six (6) selections: Monitor, Tuning, Logging, Files, Settings, and Wizards.

Monitor - A variety of gauge and dash displays.

Tuning - Allows for various parameters to be easily adjusted.

Logging - Users can freely choose the monitored object to write to the log file to better observe the ECU data.

Files - Saves and loads tuning calibrations. Also shows information about the ECU and handheld controller.

Settings - Adjust the backlight brightness and volume for sound of buttons or touchscreen and see information about the handheld.

Wizards - Creates a base calibration and performs the TPS Zero Learn function.

The ROYAL FLUSH™ EFI system will build a custom calibration for your engine based on a few easy to answer questions. To begin, Choose the Wizards icon from the main menu.

9.0 Calibration Wizard

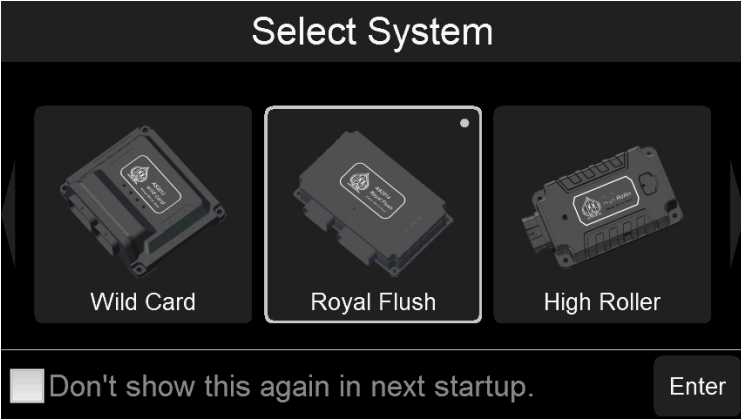
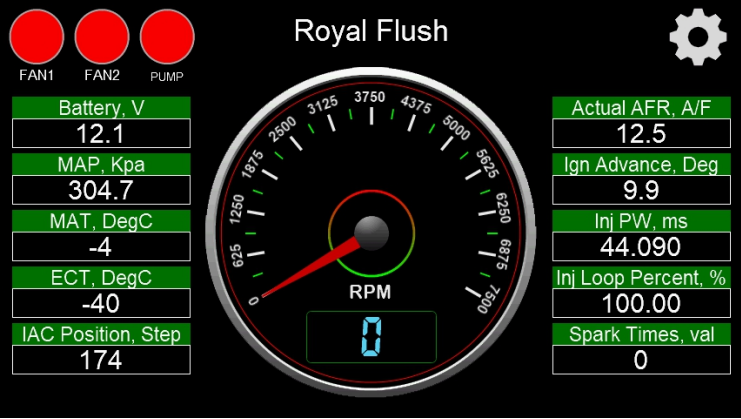
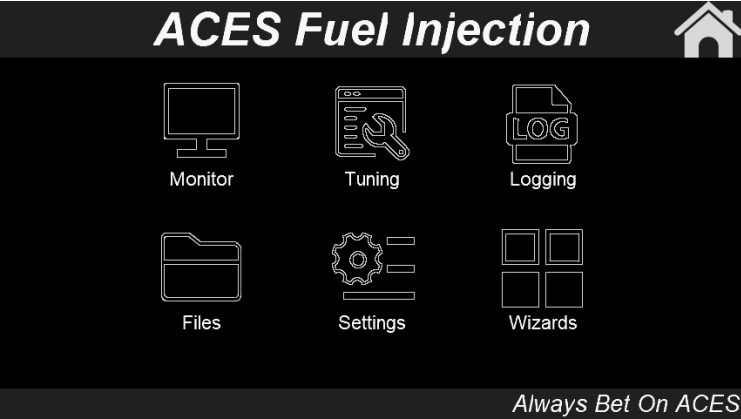
| | |
|---|--|
|  <p style="text-align: center;">Select System</p> <p style="text-align: center;">Wild Card Royal Flush High Roller</p> <p><input type="checkbox"/> Don't show this again in next startup. Enter</p> | <p style="text-align: center;">Select System</p> <p>Connect the Handheld to the wire harness and Power up the ECU. Select ROYAL FLUSH™.</p> |
|  <p style="text-align: center;">Royal Flush</p> <p>FAN1 FAN2 PUMP</p> <p>Battery, V: 12.1</p> <p>MAP, Kpa: 304.7</p> <p>MAT, DegC: -4</p> <p>ECT, DegC: -40</p> <p>IAC Position, Step: 174</p> <p>Actual AFR, A/F: 12.5</p> <p>Ign Advance, Deg: 9.9</p> <p>Inj PW, ms: 44.090</p> <p>Inj Loop Percent, %: 100.00</p> <p>Spark Times, val: 0</p> <p style="text-align: center;">RPM: 0</p> | <p style="text-align: center;">Home Screen</p> <p>Click the "⚙️" icon in the upper right corner to enter the Main Menu.</p> |
|  <p style="text-align: center;">ACES Fuel Injection</p> <p>Monitor Tuning Logging</p> <p>Files Settings Wizards</p> <p style="text-align: right;"><i>Always Bet On ACES</i></p> | <p style="text-align: center;">Main Menu</p> <p>Click Wizards from the main menu.</p> |

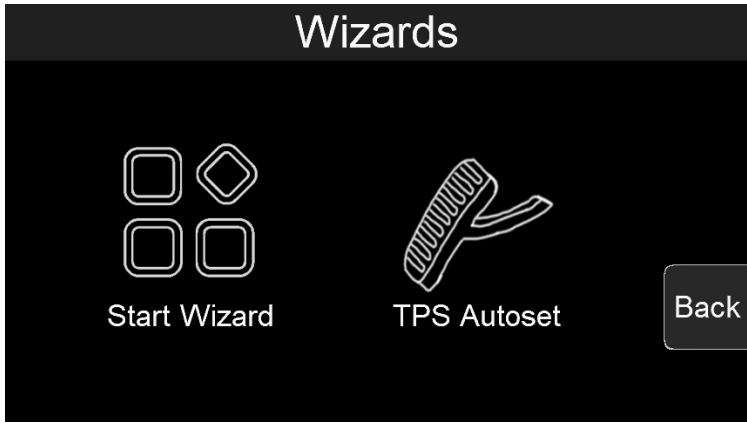

Wizards

Click Start Wizard to configure your ROYAL FLUSH™ EFI system.

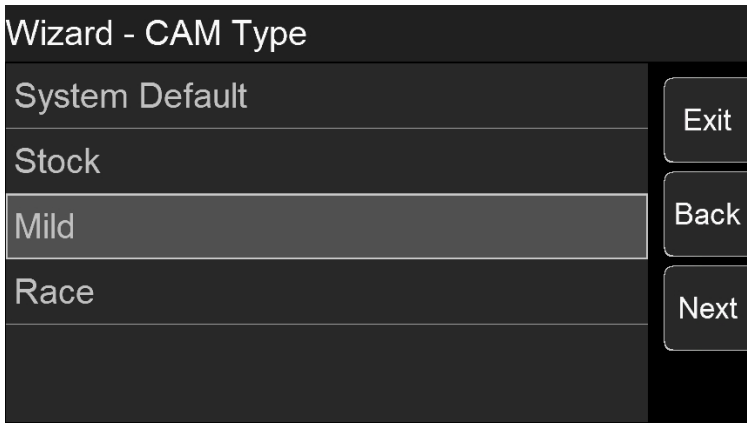

Camshaft Type

Select your camshaft type:

- Stock/Mild = This selection will work well on most applications equipped with stock or “street performance” camshafts. Choose Stock/Mild If you are unsure of your camshaft specs.
- Street/Strip = Select this if your engine has between 8” and 13” of manifold vacuum.

Press Next.

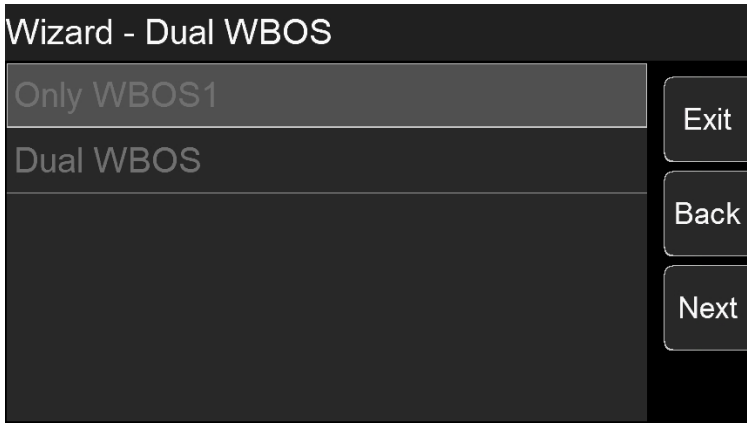

Dual WBOS

Select Only WBOS1 for your ROYAL FLUSH™.

Press Next.

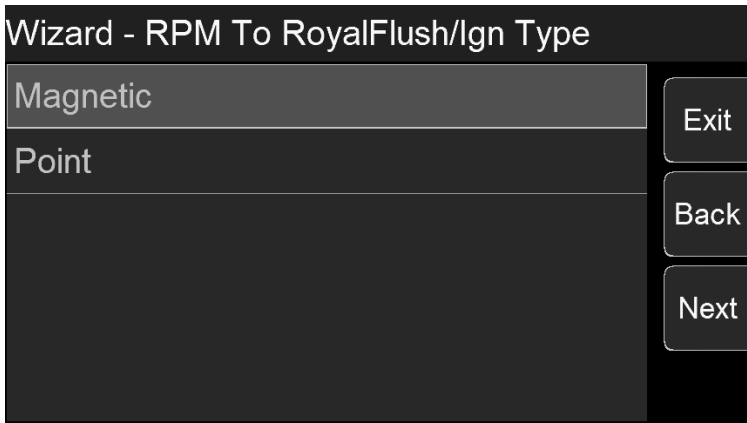

RPM To Royal Flush/Ignition Type

Select your distributor type:

- Magnetic = magnetic pickup distributors like ACES blackjack series
- Point = billet distributor with Hall effect crank signal sensor like Holley Sniper distributor

Press Next.

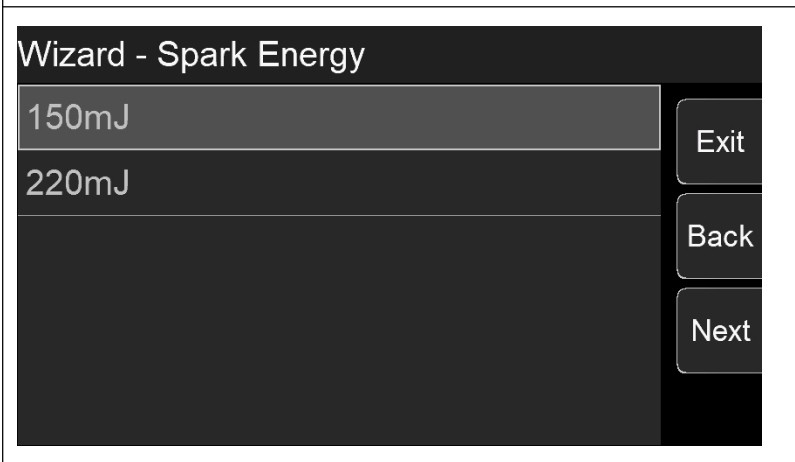
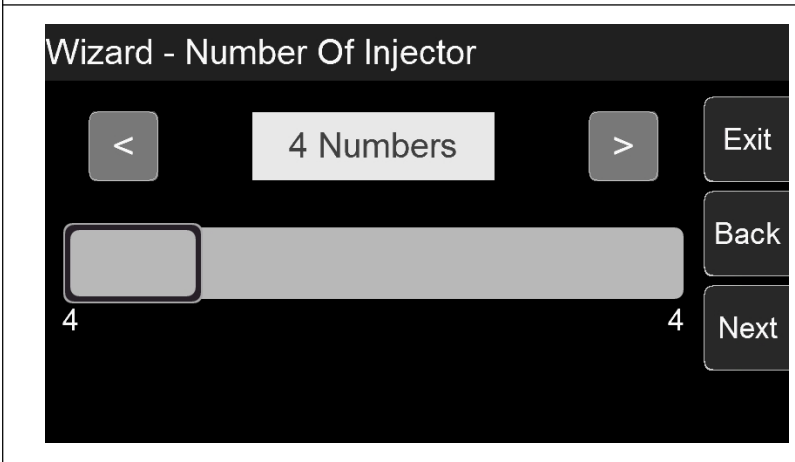
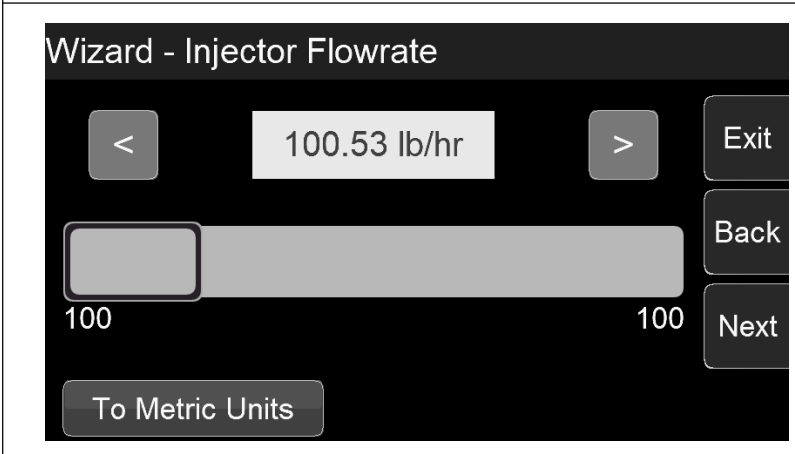
| | |
|--|--|
|  | <p style="text-align: center;">Timing Control</p> <p>Select YES, your Royal Flush will control engine timing, Select NO, ignition timing is determined by your distributor setting and engine rpm</p> |
|  | <p style="text-align: center;">Spark Energy</p> <p>Select spark energy, Ignition coil AC2008 is 150mj</p> <p style="text-align: center;">Press Next.</p> |
|  | <p style="text-align: center;">Number of Injectors</p> <p>Select 4 injectors for your ROYAL FLUSH™.</p> <p style="text-align: center;">Press Next.</p> |
|  | <p style="text-align: center;">Injector Flowrate</p> <p>The injectors of the ROYAL FLUSH™ throttle body are 100 lb./hr.</p> <p style="text-align: center;">Press Next.</p> |

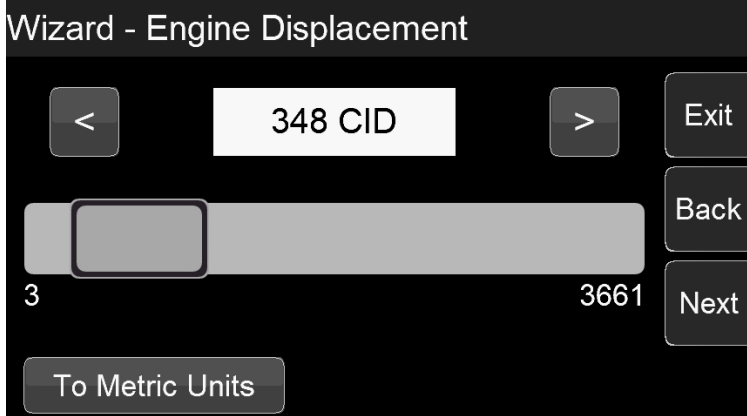

Engine Displacement

Use the slider bar to set your engine displacement.

Press Next.

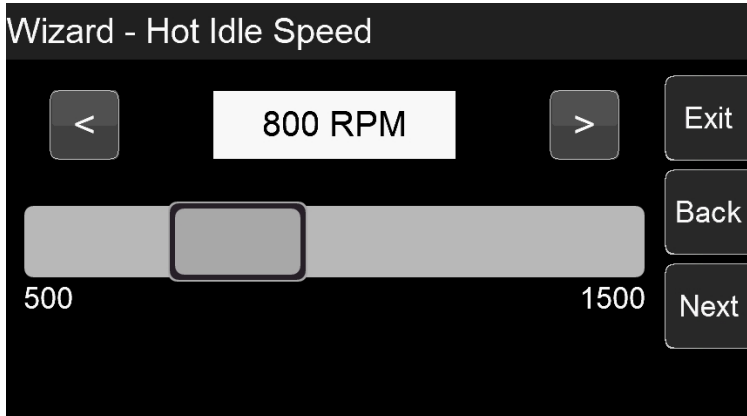

Hot Idle Speed

Use the slider bar to set your hot idle speed. This is the target RPM that will be enabled at coolant temperatures above 160 °F.

Press Next.

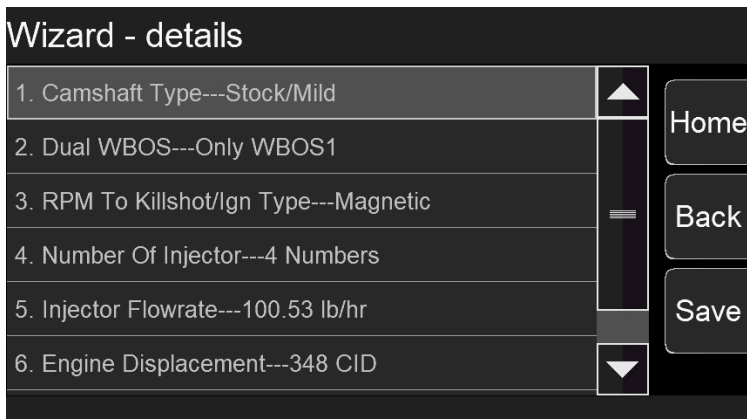

Click "Save" to save the configuration to the ECU. Click "Back" to return to the wizard to modify configuration. Or click "Home" to return to the main menu.

TPS Autoset

Click "TPS Autoset" to enter TPS self-learning page. If you select "YES", make sure the throttle is completely closed and engine is not running.

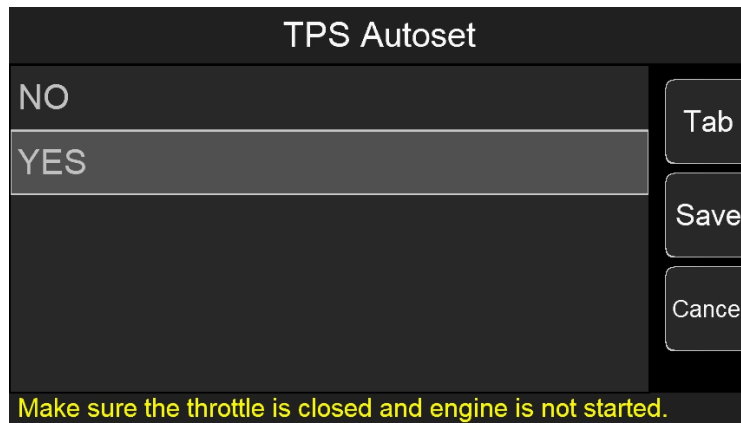

10.0 Sensor Verification

Before starting the vehicle, verify that all the sensors are reading properly. Turn the key off and cycle it back on. At this time, you should hear the fuel pump come on and run for 5 seconds. Check for fuel leaks.

On the Home Screen, with the key on and the engine off, these sensors should read as follows:

- **Engine RPM** – Will show “0.” (Will show RPM once the engine is cranking or running)
- **MAP** (Manifold Air Pressure Sensor) – Should read from 95-102kpa. At high elevations, it could read as low as 75kpa.
- **TPS** (Throttle Position Sensor) – Slowly depress the throttle to wide open. It should read 90-100 at wide open. Cable-operated throttle bodies should read 0 closed.
- **CTS** (Coolant Temperature Sensor) – Reads engine temperature. If the engine is “cold,” it should read close to ambient temperature.
- **Battery** – Reads battery voltage. Should be 12.0 volts minimum.

If ANY of these sensors is not reading properly DO NOT attempt to start the engine.

11.0 Startup Engine

At this point, you're ready to start the engine. Before attempting to start your vehicle with a newly installed Royal Flush EFI system, ACES recommends running through the following checklist to help ensure a safe and successful start:

- 1) Double-check all wiring, especially:
 - a) Power and Ground are run directly to the battery.
 - b) The small Red “IGNSW” wire from the Royal Flush ECU has power during both Key-On and Cranking.
- 2) The Royal Flush ECU, fuel pump, fuel lines, and wires are securely mounted away from heat sources and pinch points.
- 3) Wide Band Oxygen Sensor is installed in a proper location.

- 4) There are no exhaust leaks.
- 5) Throttle linkage is complete and operational from the pedal.
- 6) Handheld powers up during Key On.
 - a) Each step of the Initial Setup in the Handheld has been done.
- 7) At Key On the fuel pump primes.
- 8) There are no fuel leaks when the system is under pressure.
- 9) Calibration setting is for No Timing Control (unless using timing features, ACES recommends starting up your engine with no timing control at first start).

When ready to start the engine, watch for Engine RPM on the Handheld Dash to know that the Royal Flush ECU is getting proper input RPM signal.

Crank the engine and look at the RPM parameter. It should indicate RPM. The engine should fire and run and come to an idle. Cold engines will have high RPM, around 1200-1500, depending on engine temperature.

If you do not get an RPM signal, there is an error in the wiring or system setup. Call ACES Fuel Injection service at (423) 590-ACES for advice.

12.0 After Startup

Once the vehicle has started, look for any fuel or coolant leaks. Let the vehicle warm up while you check the following to make sure everything is operating properly:

- **Fuel Loop State** – Indicates whether the engine is “Closed Loop” or “Open Loop”. Closed Loop indicates that the ECU is adding or subtracting fuel to maintain the target air/fuel ratio. The ROYAL FLUSH™ calibrations are such that the system should be operating closed loop almost all the time.
- **Inj Percent** – This is the percentage compensation of fuel that the ECU is adding or subtracting to maintain the target air/fuel ratio at any specific moment. A value less than 100% indicates the ECU is removing fuel. A value more than 100% indicates the ECU is adding fuel. When in open loop operation, this will always stay at 100%.
- **Inj PW** – Indicates the injector pulse width. This will vary depending on the engine speed and load.
- **Target Air/Fuel Ratio** – This is the target AFR (air/fuel ratio) the ECU is trying to maintain. This will vary depending on the engine speed and load.
- **Actual AFR** – This will show the air/fuel ratio that the wideband oxygen sensor is reading. The Closed Loop Compensation should be adding or subtracting fuel all the time such that the AFR value should always be close to the Target AFR.
- **Fuel Learn State** – This indicates the state of the ROYAL FLUSH™ “Self-Tuning” operation (Learn Status). The system will automatically tune itself as you drive around. There are several conditions that must met for self-tuning to occur. The engine temperature must exceed 160° F, the system must be operating in a closed-loop mode, and

self-tuning must be enabled. The base ROYAL FLUSH™ setup has self-tuning enabled. Once the engine reaches 160° F, self-tuning should be active.

13.0 Timing Verification

Go to Handheld **Tuning>>Spark>>Advanced>>Lock Ignition Timing**, this is a switch to lock or unlock ignition timing, verifying ignition timing by lock status to check ignition timing or distributor sync, leave **Unlock** with ignition wire -timing control set, you can have the Royal Flush control timing. Set **lock** to have Royal Flush with no timing control, the timing will be based on the distributor initial, mechanical, and vacuum advance.

13.1 No Timing Control

With a timing light, verify that the timing is set to an appropriate value for your engine. Adjust as necessary. It is critical to have the timing set correctly before the car is driven with the ROYAL FLUSH™ EFI. Many drivability and idle issues can be avoided with a properly timed engine.

13.2 Timing Control

Have a timing light handy as the first step will be positioning the distributor.

- 1) Switch the ignition key ON to power the ROYAL FLUSH™ system up and go to Handheld **Tuning >>Spark>>Basic >>Static Timing**. This screen allows you to set the distributor exactly where the ROYAL FLUSH™ ECU needs it to be positioned to operate the timing.
- 2) Start the engine. Then, set the static timing to 15 degrees BTDC. Then go to Handheld **Tuning>>Spark>>Advanced>>Lock Ignition Timing**. Click **Enter** to select **Lock**. Then save. Now, ignition timing is locked at 15 degrees BTDC. Using the timing light, rotate the distributor until you see 15 degrees BTDC on the balancer. Then tighten the hold down clamp.
- 3) Set **Lock Ignition Timing** to “unlock.” Set static timing to 15 degrees BTDC. Go back to the Home Screen, and the ROYAL FLUSH™ ECU will now be controlling the ignition timing. Advancing or retarding ignition timing can make an engine want to speed up or slow down. ROYAL FLUSH™ can use this principal in another way (in addition to the idle motor) to maintain the desired idle speed. Besides giving the ECU additional influence on engine speed, the idle timing adjust feature can also react very quickly with what we call “fast adjust” which utilizes timing control by advancing or retarding ignition timing. Conversely, “slow adjust” utilizes the IAC. The ROYAL FLUSH™ ECU has two strategies of idle control. It is important to note that you will not see accurate timing at idle speed when viewing with a timing light. This is due to ECU calculations. If you rev the engine off idle, the timing will appear correctly.
- 4) Go to the Spark screen, **Tuning >>Spark>>Basic**. Here, you can adjust the idle, cruise, WOT, and cranking timing settings. It is HIGHLY recommended that you build a timing map using the ROYAL FLUSH™ EFI PC Software for the engine on which the ROYAL FLUSH™ EFI is controlling timing. The timing map built using the Handheld is very basic, and your engine will perform much more optimally with a timing curve built specifically for it.

14.0 Idle Setting

Once the engine is warmed up, the idle speed can be set to what is desired.

Select the Tuning tab. Find the target hot idle speed. Move the button left and right to adjust it. Click the button to save the new value or select CANCEL at the bottom to move out of this screen.

Whether you change the target idle or not, you need to set the throttle plates on the throttle body to an optimal position. To do so, with the engine running, select the Monitor tab. You will see the Idle screen. Look at the "IAC Position" value. This value should be between 6 and 20 with the engine in neutral and up to operating temperature. Also make sure the "TPS" shows 0. If it is not, you need to perform a TPS Zero Learn.

If the "IAC Position" value is zero, you must close the throttle plates until it reads a value of 6-20. Slowly turn the throttle shaft adjustment screw counterclockwise on the throttle body. If the IAC position is "stuck" at zero, it is likely that the engine is idling at a higher speed than you have set for the target idle speed. You need to adjust the throttle plates to resolve this issue.

If the "IAC Position" value is greater than 20, it is a good idea to open the throttle plates until the "IAC Position" value is between 6 and 20. Do this by turning the throttle shaft adjustment screw clockwise. Note that if you open the throttle plates such that the "TPS" position goes above zero, you will need to shut the vehicle off and perform a TPS Zero Learn. Then, restart the vehicle and continue adjusting the throttle plates.

Once the TPS goes above zero, the ECU goes out of its "idle" mode and will lock the IAC position to a fixed value.

When the adjustments are completed, make sure the TPS reads 0 with the engine idling.

15.0 Self-Tuning

It is time to drive the vehicle and let the system perform the self-tuning process. The best way to self-tune is to drive the vehicle under as many different operating conditions as possible - different engine speeds and loads. Start by slowly revving the engine in neutral and holding it at different speeds up to 2500 RPM. This will help the system learn these points. Then drive the vehicle, possibly using different transmission gears to learn in different areas. If you have an automatic transmission, you may want to put it in gear, and with your foot on the brake pedal, apply a SMALL amount of throttle so that the system learns in this area as well.

NOTE: There are several conditions where Learning will NOT occur. They are the following:

- If the engine is below 160° F
- When the engine detects quick accelerator pedal movement
- At certain times when the accelerator pedal is released, and the vehicle is coasting
- If learning is disabled by the user

If you would like to see if self-tuning is completed in a certain area, follow these instructions in your Handheld:

- 1) Select Monitor from the Main Menu.
- 2) Then select Monitors.
- 3) Select the Fuel Inj PW icon. The Fuel Learn Status indicates if the learn feature is active.

At this point you can drive and enjoy your ROYAL FLUSH™ EFI as it is.

Diagnostic LEDs

| LED # | Color | Function | Definition |
|-------|-------|--------------------------|---|
| 1 | Red | Power Indicator | System power indicator |
| | Blue | Engine Running Indicator | Engine running indicator, Blinking becomes faster with speed, if no Blinking during cranking, means ECU does not get RPM signal from distributor. |

TUNING REFERENCE MANUAL

The ROYAL FLUSH™ EFI allows the user to adjust some basic tuning changes to help optimize engine performance. The tuning is split up into “Basic” and “Advanced”.

The Basic Tuning allows basic calibration data changes of **Idle, Spark, Fuel, Fuel Pump, System Setting and System IO**. The Advanced Tuning is control function and 2D table that are less commonly used. These parameters require some tuning and EFI understanding before changing.

The Main Menu has 6 selections (see following figure): **Monitor, Tuning, Logging, Files, Settings, Wizards**.

Click the "" icon in the upper right corner to return to the Home Screen.

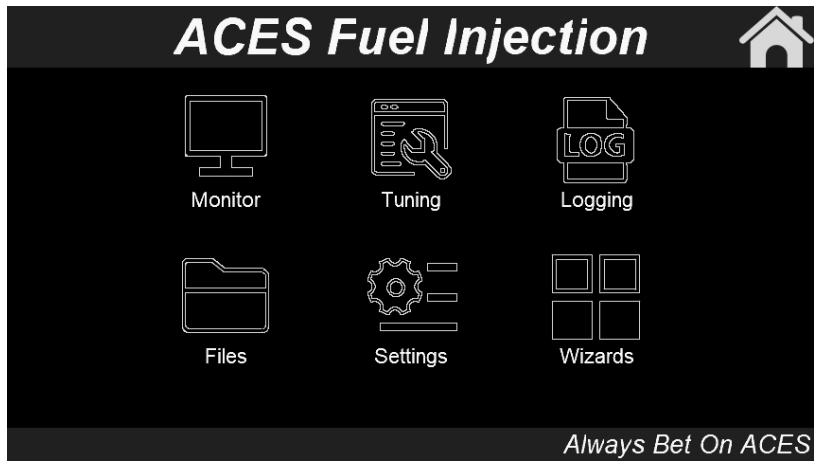

1.0 IDLE

The goal of the engine operating states is to define the state of the engine related to its operating point. This state depends basically on engine speed and load. The following states are defined here: **engine stopped**, **startup**, **idle**, **push**, **WOT**, **push fuel cutoff**, **follow**. **Follow** is an engine operating state to make engine get to idle smoothly

Click the Idle icon to enter the idle screen.

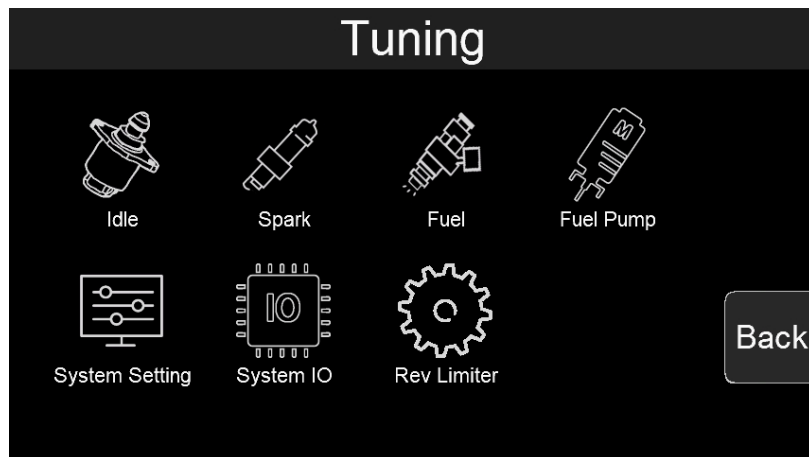

Tuning Screen

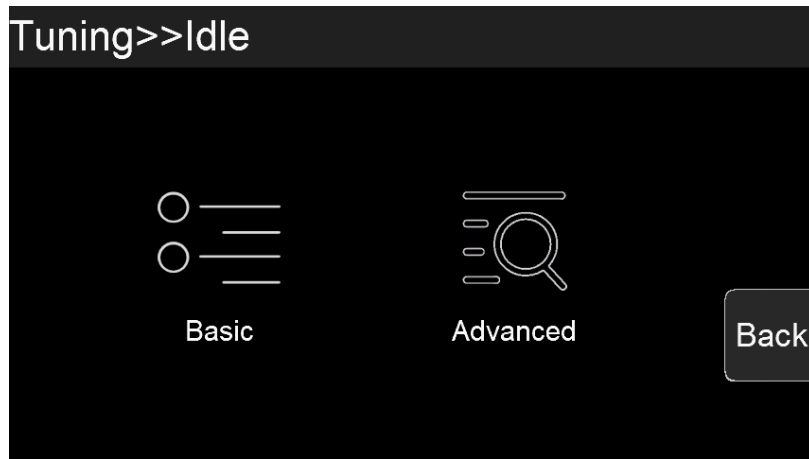

Idle Screen

1.1 Basic Idle Parameter

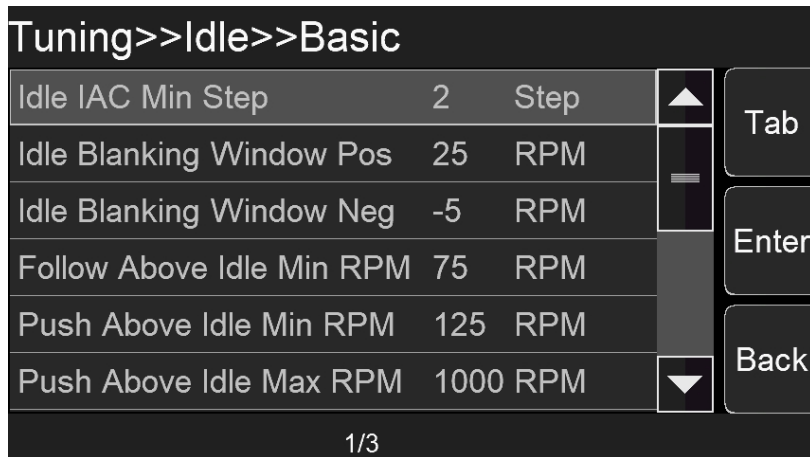

Basic Idle Screen

Hot Idle Speed - This is the target RPM that will be commanded at coolant temperatures above 160°F

Idle IAC Min Step - The minimum of IAC steps.

Idle Blanking Windows Pos - At engine idle state, when current idle speed is greater than the target idle speed, the difference between the current speed and target idle speed is less than this value, and the IAC closed-loop control is not performed. This parameter is a positive value.

Idle Blanking windows Neg - At engine idle state, when current idle speed is less than the target idle speed, the difference between the current speed and target idle speed is less than this value, and the IAC closed-loop control is not performed. This parameter is a negative value.

Follow above idle Min RPM - Min threshold RPM to get into follow states.

Push above idle Min RPM - Min threshold RPM to get in to push states.

Push above idle Max RPM - Max threshold RPM to get in to push states

Startup Air Fast Decay Cycle - After the engine is started, the starting air quickly decays to the target idle speed according to a certain period. The smaller the value, the faster the air decays.

Startup Air Slow Decay cycle - After the engine is started, the starting air quickly decays to the target idle speed in a certain period. When the actual speed is close to the target idle speed, the air decay speed should be slowed down. The larger the value, the slower the air decay.

Push Air Increase Ratio - This Value is Air (IAC motor steps) increase ratio during throttle body open process, bigger number is increasing fast.

Push Air Decay Ratio - This Value is Air (IAC motor steps) decrease ratio during throttle body close process.

Follow Air Decay Ratio - This Value is Air (IAC motor steps) decrease ratio once engine is at Follow state, bigger number is decreasing fast to get idle target quickly, but too fast, engine is easy to shut down, smaller number will cause engine stuck at Follow state with high RPM long time.

Fan On Add Air - How much percent air will be added during Fan On.

Fan On IAC Loop Lock Time - Idle loop control will be locked in a split second, then idle closed loop will keep operating soon. This strategy is to make idle speed smoother now when the fan is turned on.

3.2 Advanced Idle Parameter

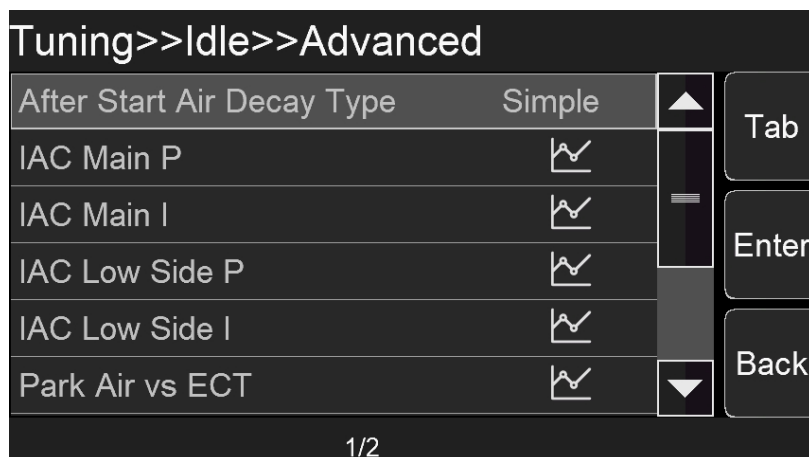

Advanced Idle Screen

After Start Air Decay Type -- If you select this option, the speed of starting air attenuation is determined by the 1D table, and the attenuation speed is determined by the ECT look-up table

IAC Main P

Current idle speed is higher than target idle speed, the setting of proportion.

IAC Main I

Current idle speed is higher than target idle speed, the setting of integrate.

IAC Low Side P

Current idle speed is lower than target idle speed, the setting of proportion.

IAC Low Side I

Current idle speed is lower than target idle speed, the setting of integrate.

Park Air vs ECT

This is the % position the IAC motor will be at during cranking and immediately after the engine starts. If it is too high, the engine RPM speed will be at too high once it starts - too low and poor starting will result. Note that this is a temperature-based table. The percentage value changed in the handheld offsets this entire curve.

Speed Raise Air

This is the % position of IAC for adjusting peak RPM after engine startup.

Idle Target Speed

1D table for idle target speed vs engine coolant temperature.

Startup Air Fast Decay Cycle

1D table for Startup Air is decaying fast to get to target idle speed

Startup Air Slow Decay Cycle

1D table for Startup Air is decaying slow to get to target idle speed

2.0 SPARK

2.1 Basic Spark Parameter

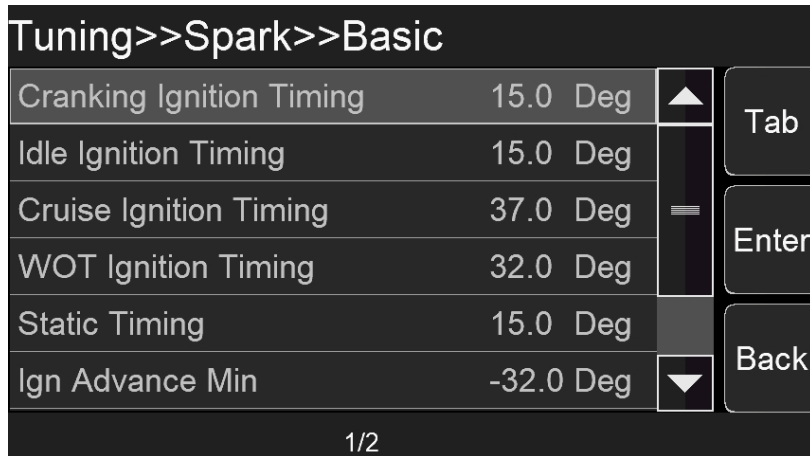

The screenshot shows a menu titled "Tuning>>Spark>>Basic" with a list of parameters and their values. The parameters are: Cranking Ignition Timing (15.0 Deg), Idle Ignition Timing (15.0 Deg), Cruise Ignition Timing (37.0 Deg), WOT Ignition Timing (32.0 Deg), Static Timing (15.0 Deg), and Ign Advance Min (-32.0 Deg). To the right of the list are four buttons: Tab, Enter, and Back. At the bottom of the screen is a page indicator "1/2".

| Parameter | Value | Unit |
|--------------------------|-------|------|
| Cranking Ignition Timing | 15.0 | Deg |
| Idle Ignition Timing | 15.0 | Deg |
| Cruise Ignition Timing | 37.0 | Deg |
| WOT Ignition Timing | 32.0 | Deg |
| Static Timing | 15.0 | Deg |
| Ign Advance Min | -32.0 | Deg |

Basic Idle Screen

Crank Ignition Timing

Crank ignition advance is normally setting to 15 for most of engine to help quick start.

Idle Ignition Timing

18-34 degrees is typically used at idle. The larger the camshaft, the more timing is usually used.

Cruise Ignition Timing

32-48 degrees is typically used when cruising for optimal fuel economy.

WOT Ignition Timing

Older V8 engines are usually between 32-38 degrees (naturally aspirated).

Static Timing

These parameters should be used when having the Royal Flush EFI control the ignition timing to sync actual engine timing with commanded timing. Use the "static timing set" function and set the timing to a fixed value such as 15 degrees. Rev the engine up as high as possible (using appropriate caution/safety). Verify that the engine timing matches at all RPMs the Static Value setting. If it does not, the Timing offset will need to be changed until the timing of the engine matches the value set in the Tuning>>Spark>>Basic.

Timing Offset

Use this value to retard or advance the timing or sync timing at higher RPMs. These values are sett to 0 in the base

calibrations. Some ignition modules may need this number altered if the commanded timing does not match the commanded timing as engine speed increases. If the timing starts to retard as rpm increases, this number can be increased in order for the timing to match.

Ign Advance Min

Min threshold of ignition advance

Ign Advance Max

Max threshold of ignition advance

Engine Max RPM

Max RPM of engine, Rev limiter is spark control.

Cut Ign&Fuel – Cut ignition and fuel when the Engine Max RPM is hit. Means that ignition and fuel will be removed from individual cylinders as needed to limit RPM.

*The strategy of fuel and ignition cut is individual cylinder control, it performs engine stable and smooth at Max RPM, Launch RPM, Burn RPM status.

2.2 Advanced Spark Parameter

Lock Ignition Timing

This is a switch to lock or unlock ignition timing, verifying ignition timing by lock status to check ignition timing or distributor sync, leave Unlock with ignition wire -timing control sets, you can have the Royal Flush control timing. Set lock to have Royal Flush no timing control, The timing will be based on the distributor initial, mechanical, and vacuum advance.

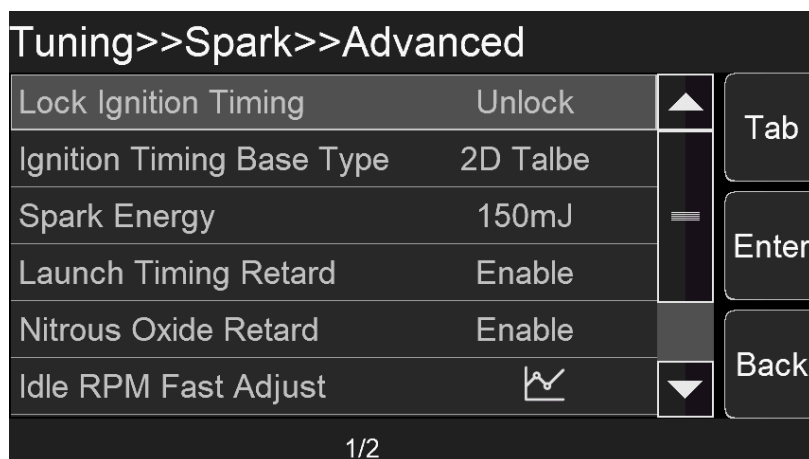

Advanced Spark Screen

Ignition Timing Base Type

Default setting is “Simple”, this option is to select simple or 2D table of MBT Timing, Using the ACES PC Tuning software allows for a user to build a custom ignition timing curve.

The MBT Timing is the main ignition table in the calibration. The MBT Timing Table is a 3D table used for setting ignition timing throughout the operating range of your engine. The first step in calibrating the MBT Timing table is to use the table to fill in your timing values. This table gives you a general idea of ignition timing during starting, idle, cruise, transition or high load, and deceleration. These values will get you in a safe area to start the tuning process.

Spark Energy

Royal Flush has adjustable spark energy output, 150mj/200 mj, ACES recommends using AC2008 ACES BLACKJACK Pro Series Ignition Coil to get 150mj. It is beneficial to cold start, maintaining idling stability and improved fuel economy.

Launch Timing Retard

This feature will be activated when the launch button is applied. The Launch retard is used to offset the ignition timing after the launch button is released. It can optimize traction immediately after launch

Nitrous Oxide Retard

The Royal Flush system can be configured to automatically retard timing when a Nitrous Oxide System is utilized.

Idle RPM Fast Adjust

The ECU modifies commanded timing at idle to help maintain the target idle speed. This is a 1D graph used to vary ignition timing to help regulate idle speed. The horizontal axis of the graph represents the difference between the actual idle speed and the target idle speed, and the vertical axis of the graph represents the number of degrees to alter the ignition timing. If the idle speed is too high, the ECU will retard the timing by the amount specified in the graph. If the idle speed is too low, the ECU will advance the timing by the amount specified in the graph. It is recommended to set this entire table to zero as a starting point. Add timing trim only if you are otherwise unable to achieve a smooth, stable idle.

IAT Adjust

The IAT Adjust table is used to trim the ignition timing vs. inlet air temperature. Often used on boosted applications as a safety mode. Ignition timing is reduced at very high air temperature readings to avoid detonation. Note that the trim values in this table are added (positive values) or subtracted (negative values) from the base ignition timing.

Idle ECT Adjust

The Idle ECT Adjust is used to trim the ignition timing vs coolant temperature at idle. Sometimes used on N/A applications with very large camshafts to help with warmup. A few degrees of additional timing during warmup can help quite a bit. Note that the trim values in this table are added (positive values) or subtracted (negative values) from the base ignition timing.

3.0 FUEL

3.1 Basic Fuel Parameter

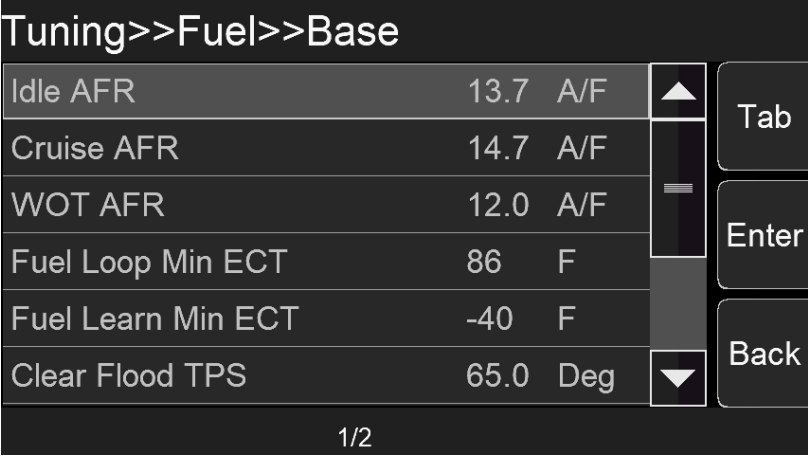

| Tuning>>Fuel>>Base | | |
|--------------------|----------|---|
| Idle AFR | 13.7 A/F | ▲ |
| Cruise AFR | 14.7 A/F | ■ |
| WOT AFR | 12.0 A/F | ≡ |
| Fuel Loop Min ECT | 86 F | ■ |
| Fuel Learn Min ECT | -40 F | ■ |
| Clear Flood TPS | 65.0 Deg | ▼ |

1/2

Basic Fuel Screen

Idle AFR

Target AFR of fuel control when the engine is at Idle, typically between 13.5 and 14.7. Engines with larger cams may need a richer setting for smoothest idle.

Cruise AFR

Target AFR of fuel control when the engine is at Cruise, typically between 13.5 and 14.7. Engines with larger cams may need a richer AFR.

WOT AFR

Target AFR of fuel control when the engine is at WOT, typically between 12.5 and 13.2 on Naturally Aspirated engines. Running richer may reduce power. Running leaner may reduce power or cause potential engine damage.

Fuel Loop Min ECT

Minimum engine coolant temperature to enable Fuel Loop. Fuel loop will be active above this setting.

Fuel Learn Min ECT

Minimum engine coolant temperature to enable Fuel Learn. Fuel Learn will be active above this setting.

Clear Flood TPS

If the TPS value is at 65 or higher during cranking, the ECU will operate in Clear Flood mode, meaning that it will trigger the ignition but will not fire the injectors.

Fuel Power-On Percent

This value is multiplying fuel PW of firing injectors once ECU power on to wet throttle body and manifold to help quick start.

Fuel Prime Percent

This value is multiplying fuel PW of first injection during engine cranking.

Rated Injector Pressure

This value is injector working pressure, fuel pressure of ACES fuel injector is 43PSI.

After Start Decay Cycle

After engine startup, engine RPM will get to idle from peak RPM, during this period start air will decay out, smaller number of decay cycle will decay fast, engine goes to idle faster.

After Start Decay Rate

After engine startup, engine RPM will get to idle from peak RPM, during this period start air will decay out, bigger number of decay rate will decay fast, engine goes to idle faster.

3.2 Advanced Fuel Parameter

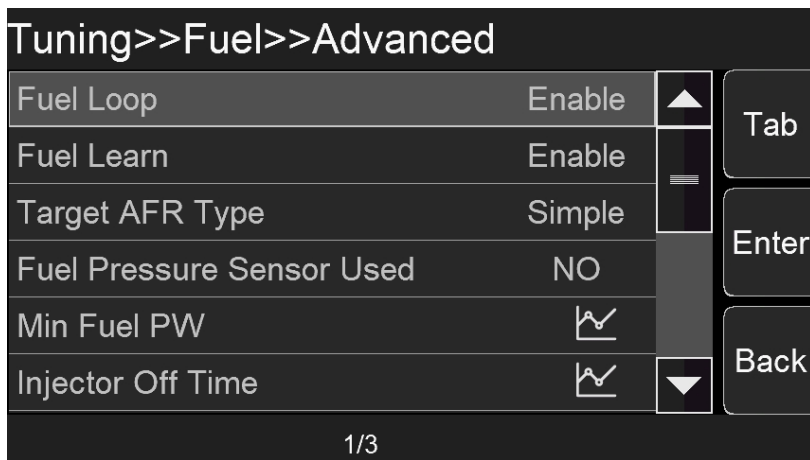

Advanced Fuel Screen

Fuel Loop

This option is to enable or disable fuel loop control. The default setting is Enable fuel loop control. There is typically no reason to turn off closed loop operation unless you suspect an oxygen sensor problem and want to disable the sensor.

Fuel Learn

This option is to enable or disable fuel learn control, default setting is Enable fuel learn control. If enabled, self-tuning is

performed. Learning should be enabled when an engine is first run with the ECU and the tuning process is occurring.

Target AFR type

The Simple option is a value at different engine state, The Target AFR Table is a 2D table used for setting target air/fuel ratios throughout the operating range of the engine.

Fuel Pressure Sensor Used

Fuel pressure sensor default setting is NO in Royal Flush EFI system. Royal Flush EFI system fuel pressure setting is 3 bar or 45 psi.

Min Fuel PW

Injector close time.

Injector Off Time

Injector opening time vs different battery voltage.

MAT Fuel Enrichment

The Manifold Air Temp Enrichment table is used to compensate for air density changes with inlet air temperature. It can also be used in a safety mode to add additional cooling fuel at very high inlet air temperatures on boosted applications.

After Start Decay Rate

This table is displayed as a 2D graph of the rate at which the after-start enrichment will decay out based on engine temperature. The decay rate is shown as the number of crank pulses that must be received by the ECU to reduce the after-start enrichment. The higher you set these values, the longer it would take for the after-start fuel to decay out once it was applied.

Acceleration Enrichment vs TPS

Adds additional momentary fuel based on the rate of change of the TPS. Same function as an accelerator pump on a carburetor.

TPS Acceleration Enrichment vs ECT

Displays a 2D graph of acceleration enrichment fuel applied in ECT change. This 2D graph is increasing or decreasing the 3D table of TPS base film which is activated to running at engine state of acceleration and deceleration.

MAP Acceleration Enrichment vs ECT

Displays a 2D graph of acceleration enrichment fuel applied in ECT change. This 2D graph is increasing or decreasing the 3D table of MAP base film which is activated to running at engine state of acceleration and deceleration.

TPS Acceleration Decay Rate

Displays a 2D graph of TPS acceleration enrichment fuel decay rate applied in ECT change.

MAP Acceleration Decay Rate

Displays a 2D graph of MAP acceleration enrichment fuel decay rate applied in ECT change.

4.0 Fuel Pump

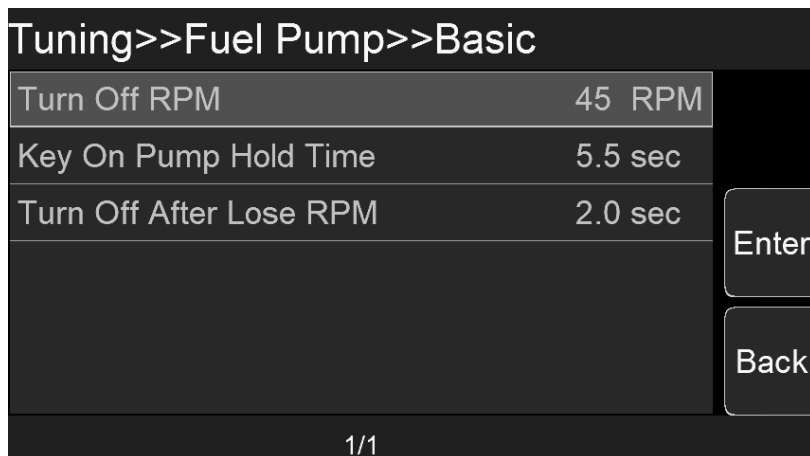

4.1 Turn Off RPM

Engine RPM lower than setting numbers, fuel pump will turn off.

4.2 Key-On Pump Hold Time

When Key-On without engine crank, how long the fuel pump will be powered on.

4.3 Turn Off After Lose RPM

When ECU lose crank signal, how long ECU will take to turn off fuel pump.

5.0 System Setting

5.1 Basic System setting

Number Of Injector

This parameter is a part of the ECU calculation to determine the amount of fuel to inject. Enter the number of cylinders the engine has. This must be entered correctly, or the engine will not run correctly, if at all in some cases.

For the ROYAL FLUSH is 4 injectors.

Engine Displacement

This parameter is a part of the ECU calculation to determine the amount of fuel to inject when running. Enter the engines displacement in cubic inches. This must be entered correctly, or the engine will run richer or leaner than intended.

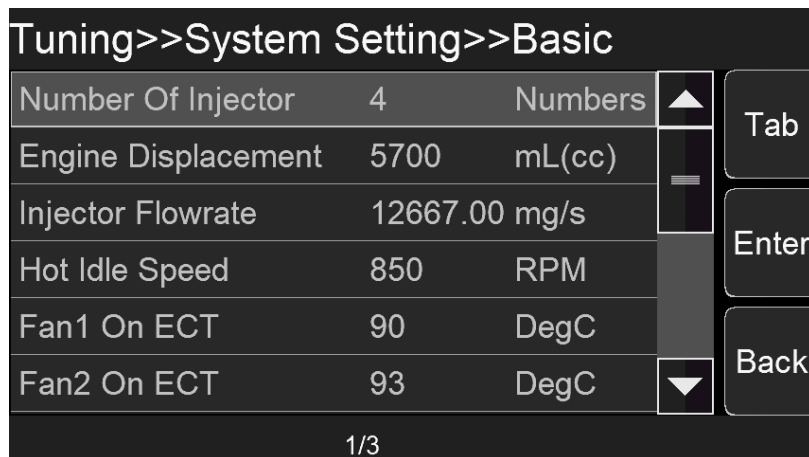

Basic System Setting Screen

Injector Flowrate

This parameter is a part of the ECU’s calculation to determine the amount of fuel to inject when running. It is also used for fuel flow and mileage calculations. Enter the flow rate of the injectors in lb/hr. This must be entered correctly, or the engine will run richer or leaner than intended. Keep in mind that fuel pressure affects flow rate. When manufacturers rate injectors, it is at a certain fuel pressure. Injectors from ACES are rated at 45 psi.

Hot Idle Speed

Set idle speed of warm engine.

5.2 Advanced System setting

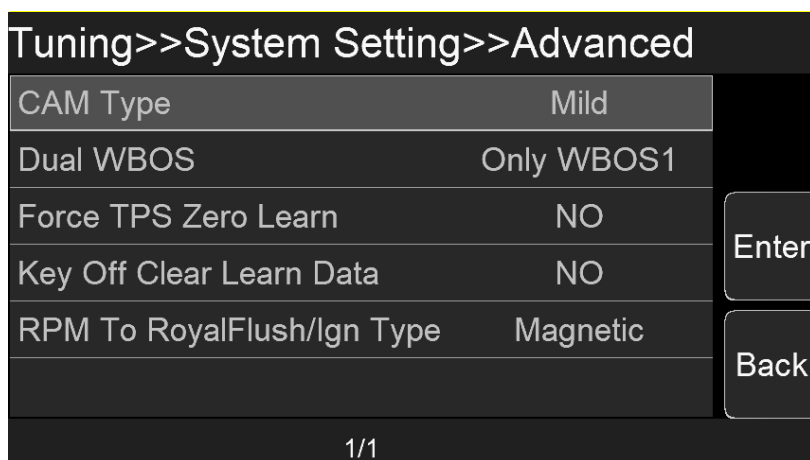

Advanced System Setting Screen

Dual WBOS

Select Only WBOS1 for your ROYAL FLUSH EFI system.

Force TPS Zero Learn

Throttle zero position is auto-learn strategy in Royal Flush ECU, choose yes to do TPS Zero Learn again.

Key Off Clear Learn Data

Choose YES, then turn the ignition key off, wait 5 seconds, then turn the key on, all the Learn data (fuel learn table, IAC learn steps, ETC learn steps etc.) will be cleared.

RPM To Royal Flush / Ignition Type

Select your ignition type:

Magnetic - magnetic pickup distributors like ACES blackjack series or MSDs

Points - billet distributor with Hall effect crank signal sensor like Holley Sniper distributor

Camshaft Type

Select your camshaft type:

Stock/Mild - This selection will work well on most applications equipped with stock or "street performance" camshafts. Choose Stock/Mild if you are unsure of your camshaft specs.

Street/Strip - Select this if your engine has between 8" and 13" of manifold vacuum.

6.0 System IO

Fan1 On ECT--195° F

Fan2 On ECT--205° F

Fan1 Off ECT--180° F

Fan2 Off ECT--190° F

Fan1 On Delay Time

Fan2 On Delay Time

The ECU has an output to operate a cooling fan. This output switches to ground and is wired to the negative terminal of a relay to activate the fan. This parameter defines the coolant temperature that must be exceeded to activate the fan. It needs to be set higher than Fan Off Temperature (*F).

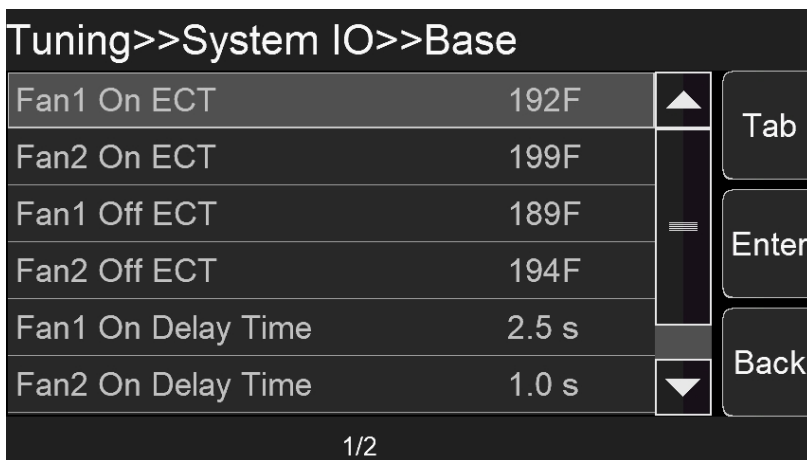

System IO Screen

7.0 Rev Limiter

7.1 Rev Limiter Basic Setting

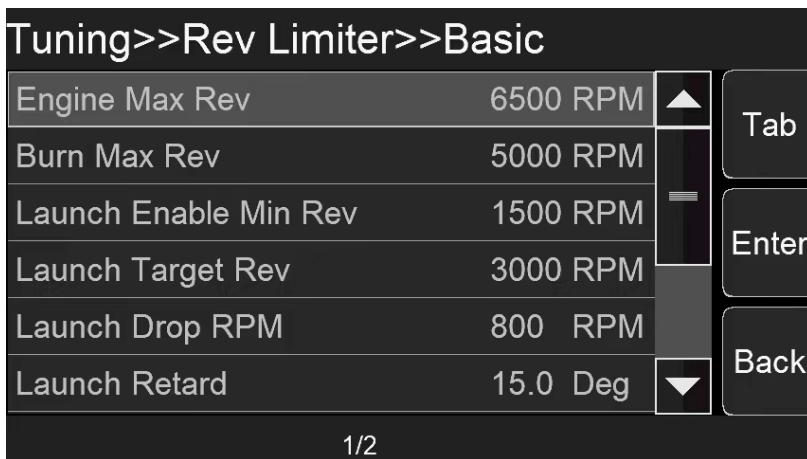

Engine Max RPM

Max RPM of engine, Rev limiter is spark control.

Cut Ign&Fuel – Cut ignition and fuel when the Engine Max RPM is hit. Means that ignition and fuel will be removed from individual cylinders as needed to limit RPM.

*The strategy of fuel and ignition cut is individual cylinder control, it ensures the engine performs stable and smooth at Max RPM, Launch RPM, Burn RPM status.

Launch Target Rev

This limit is activated when 12 volts are applied to the Launch Wire. It is adjustable from Launch Enable Min Rev to 15,000 rpm.

Launch Enable Min Rev

Launch control will be enable above this setting.

Burn Max Rev

Burnout Rev Limit. This limit is activated when 12 volts are applied to the Burn wire. It is adjustable from 2,000 to 15,000 rpm.

Launch Drop RPM

This option is for Manual shift applications using the clutch between shifts. This RPM value will set up a window so the Launch limiter will not reactivate when using the clutch between shifts. This RPM will be set lower than Launch RPM.

Launch Retard

This feature will be activated when the launch button is applied. The Launch retard is used to offset the ignition timing during the 8 seconds after the launch button is released. It can optimize traction immediately after launch.

Launch Retard Ramp Time

This adjustment determines the rate (over time) that timing will be ramped back into the engine until the run curve timing is met. When driver releases the clutch, the engine RPM meets Launch Drop RPM, then timing will begin ramping back into the engine. The Ramp determines how fast this is done.

Launch Filter Coefficient

This is a filter coefficient that smooth timing curve from engine run to launch and ramp back.

N2O Retard

The retard is activated when 12 volts are applied to the Nitrous wire. The maximum retard allowed by the ignition is a total of 30°

N2O Retard Ramp Time

The retard step can be ramped to and from its full retard amount. It is adjustable from 0-2.5 seconds in 0.01 second increments.

7.2 Rev Limiter Advanced Setting

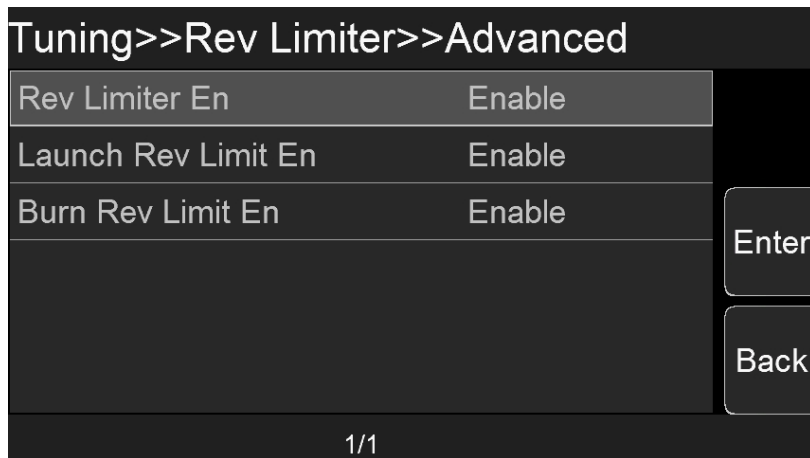

Rev Limiter En

This option is to enable or disable Rev Limiter controller, default setting is Enable.

Launch Rev Limit En

This option is to enable or disable Launch controller for Royal Flush, default setting is Enable.

Burn Rev Limit En

This option is to enable or disable Burnout controller for Royal Flush, default setting is Enable.

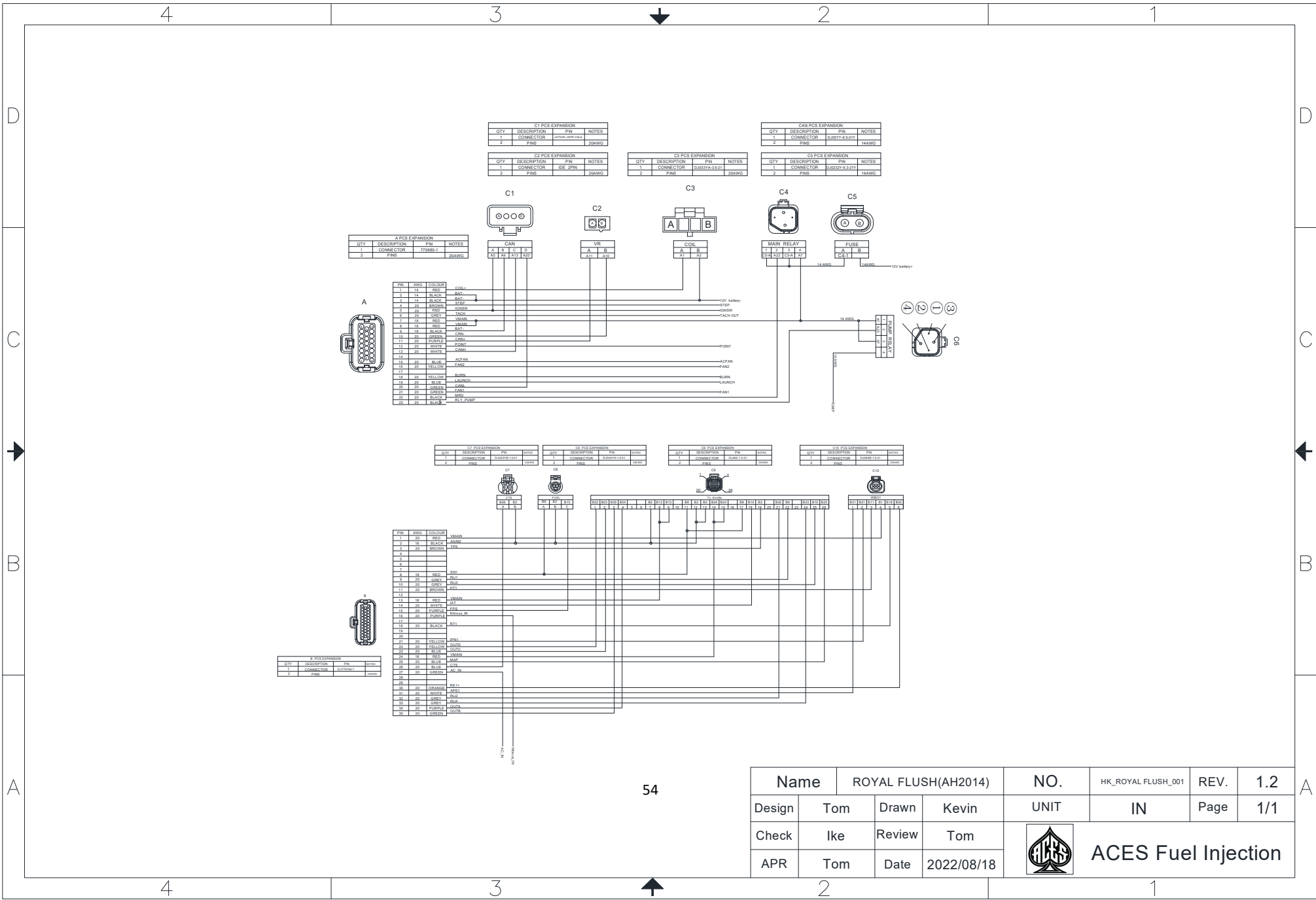

| | | | | | | | |
|--------|-----|---------------------|------------|--|--------------------|------|-----|
| Name | | ROYAL FLUSH(AH2014) | | NO. | HK_ROYAL_FLUSH_001 | REV. | 1.2 |
| Design | Tom | Drawn | Kevin | UNIT | IN | Page | 1/1 |
| Check | Ike | Review | Tom |  ACES Fuel Injection | | | |
| APR | Tom | Date | 2022/08/18 | | | | |

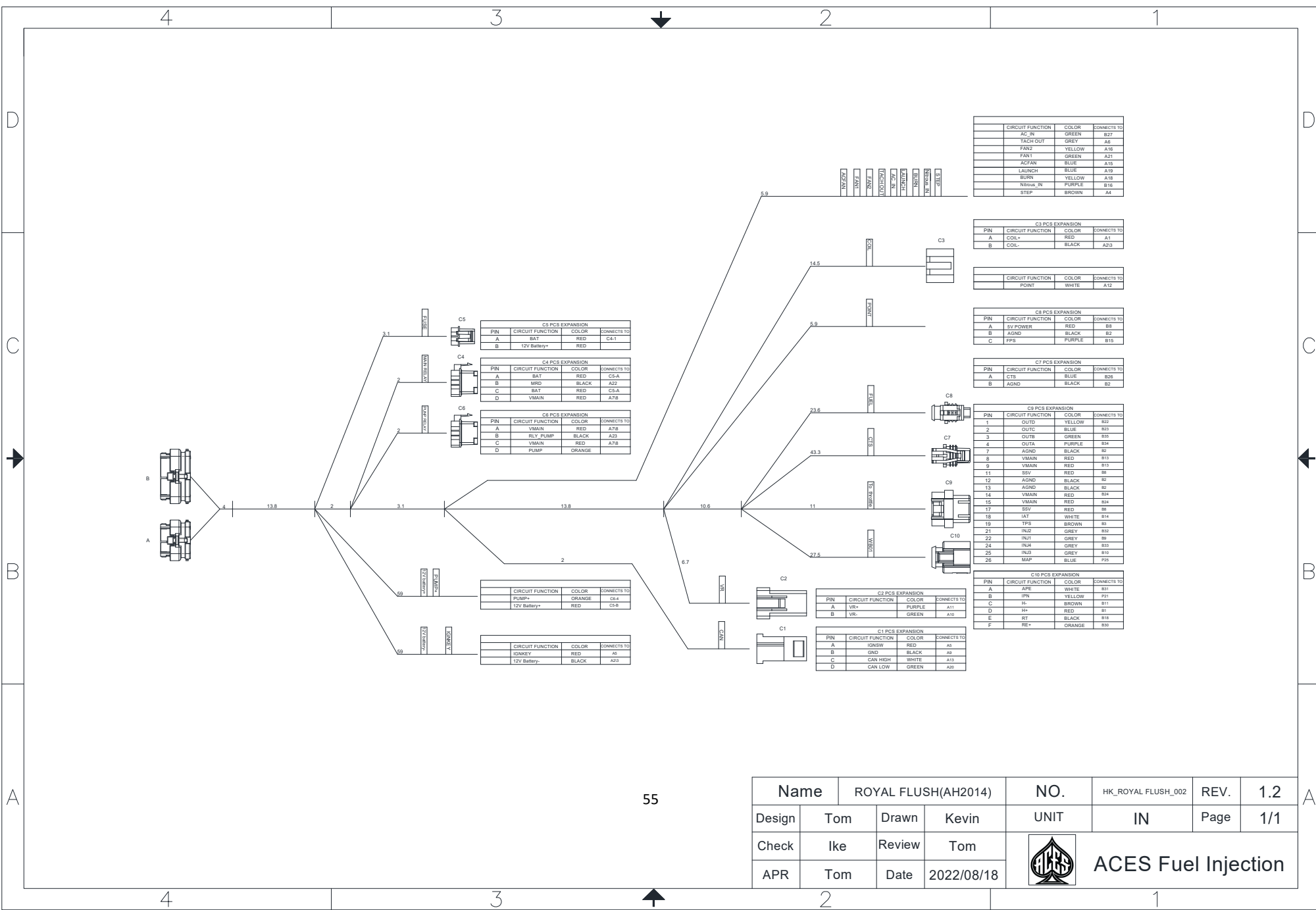

55

| | | | | | | | |
|--------|-----|---------------------|------------|------|--------------------|------|-----|
| Name | | ROYAL FLUSH(AH2014) | | NO. | HK_ROYAL FLUSH_002 | REV. | 1.2 |
| Design | Tom | Drawn | Kevin | UNIT | IN | Page | 1/1 |
| Check | Ike | Review | Tom | | | | |
| APR | Tom | Date | 2022/08/18 | | | | |

ACES Fuel Injection

ACES FUEL INJECTION

1441 Market Street

Dayton, TN 37321

(423) 590-ACES

www.acesefi.com