

LOAD CONTROLLER I

ON-BOARD COMPRESSOR CONTROL SYSTEM

Single Gauge P/N 25655



MN-342
(02606)
ECR 5713

This installation should be done after the Air Spring kit has been installed.

All preassembled gauge panels have been 100% leak and function tested. Do not attempt to tighten, loosen, or adjust any fittings or connections. This will likely cause a leak or malfunction and void the warranty.

If you have any questions, please call our Technical Support: 1-800-248-0892 ext. 2.

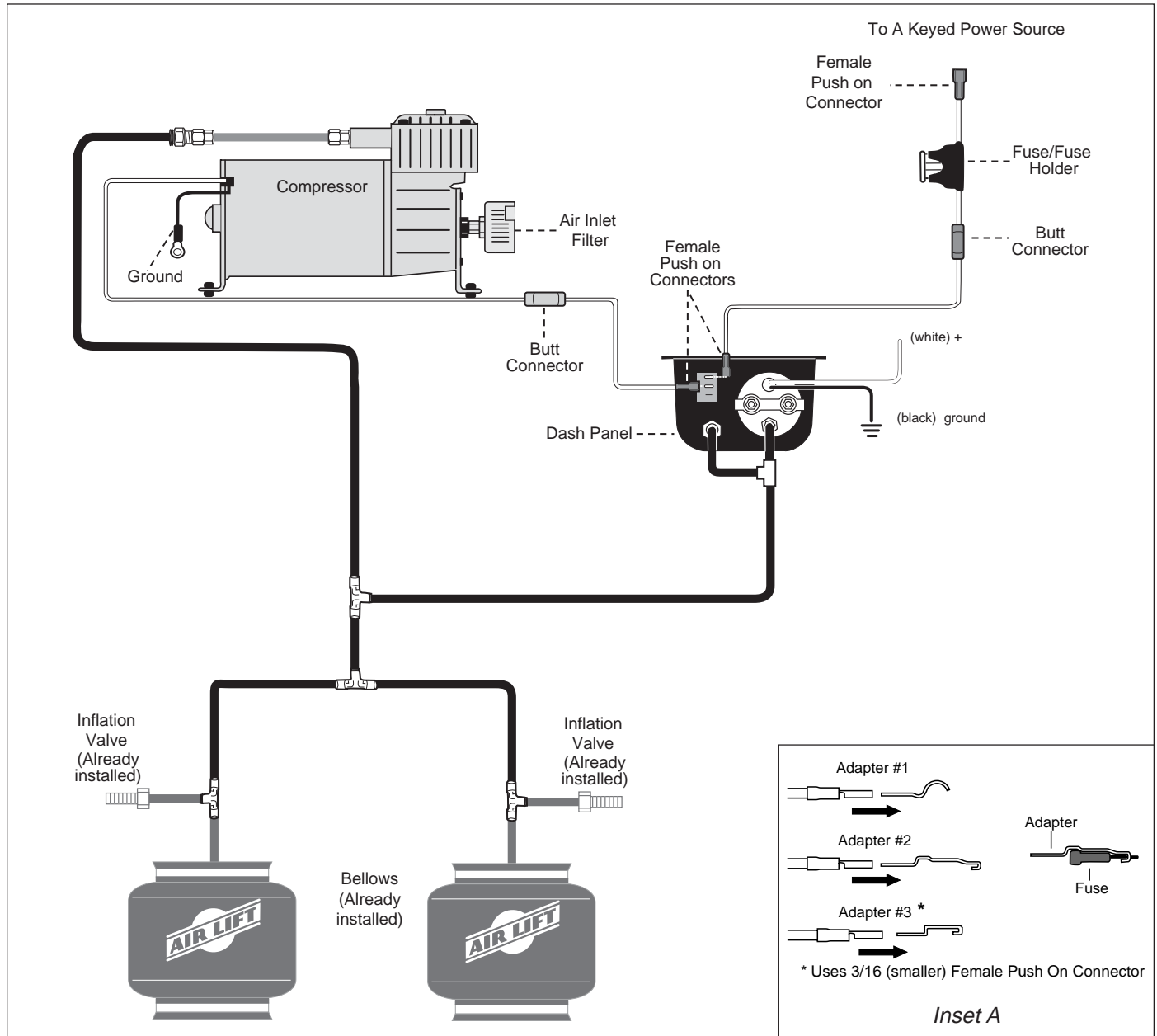

Figure 1

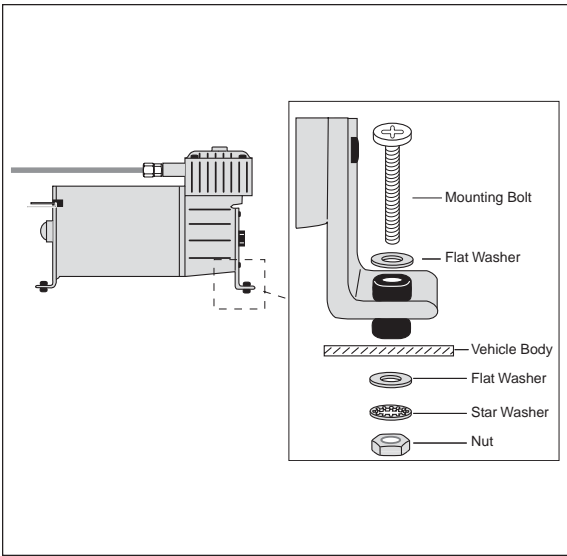

Figure 2

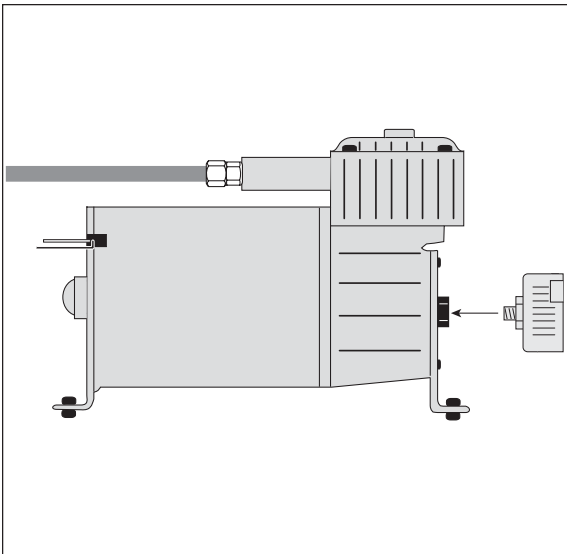

Figure 3

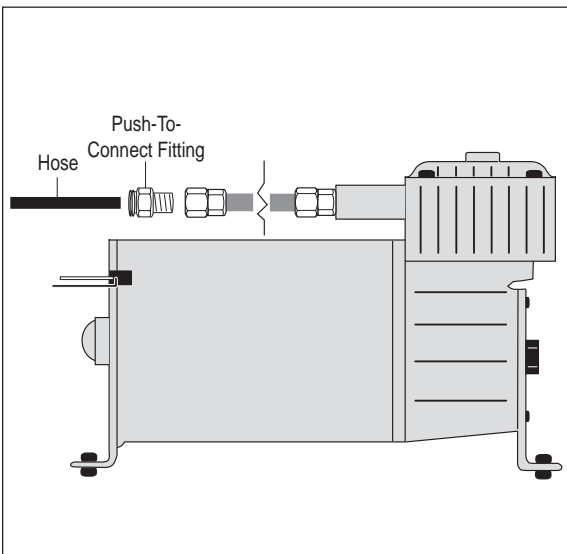

Figure 4

I. Mounting the Compressor

1. Select a rigid convenient mounting location on the frame or in a storage area. The location selected should shield the compressor from the elements. **IMPORTANT: Be careful to shield the compressor from heat sources. Do not mount the compressor in the engine compartment. Doing so can cause premature failure to the compressor**
2. Using the mounting holes on the compressor legs as a guide, mark the mounting hole locations.
3. Remove the compressor and center punch and drill four $\frac{13}{64}$ " diameter holes.
4. Use the supplied screws and nuts to mount the compressor (Figure 2).
5. Attach the air filter to the inlet port at the back of the compressor (Figure 3).
6. Install the fitting into the pressure port side of the leader hose (Figure 4).

II. Mounting the Dash Panel

1. Select a convenient, sturdy mounting location for the gauge panel.
2. Using the gauge panel mounting bracket as a template, position the gauge panel to the mounting surface.
3. Secure with two self-tapping screws.

III. Wiring the Electrical Connections

1. Install the yellow ring terminal to the compressor motor ground (black) wire. Select a good ground location, and attach the ring terminal with the self-tapping screw provided.
2. Determine the length of supplied (red) wire required to connect the dash panel to the compressor.
3. Connect the (red) wire from the panel to the (red) wire on the compressor using a blue butt connector (Figure 1). Connect the other end of the wire to the push switch using the blue $\frac{3}{16}$ female push on connector. With your thumb against the front side of the switch, push the connector onto one of the terminals on the back of the ON/OFF switch on the gauge panel
4. Install the 30 amp fuse and fuse holder assembly. At one end attach a female push on connector and the other end a blue butt connector. Connect the fuse assembly to the accessory circuit

in the fuse block. Use a test light to determine which open terminal, (accessory, etc.) works only when the ignition is in the "on" or accessory position. **NOTE: Connect the adapter to the "Hot" side of the fuse (use a test light to determine).** Connection to the fuse terminal will depend on what type of fuse your vehicle uses. If the vehicle uses the barrel type fuse, use adapter #1. If the vehicle uses the standard spade type fuses, use adapter #2. Many late model vehicles use a smaller spade type fuse which requires adapter #3. See Inset A on the first page.

5. Determine the length of supplied (red) wire required to connect the dash panel to the fuse assembly. Cut and crimp the wire into the butt connector (Figure 1). Connect the other end of the wire to the push switch using the blue $\frac{3}{16}$ " female push on connector. With your thumb against the front side of the switch, push the connector onto the remaining terminal on the back of the ON/OFF switch on the gauge panel.
6. Route the white wire for the illuminated gauge to an accessory power source. Attach the black wire to an adequate ground.

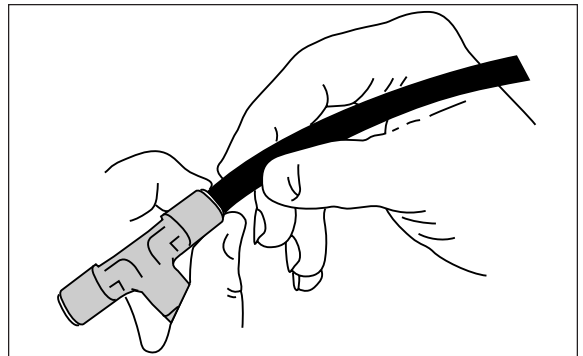

Cut off excess air line squarely. Install the air line into the fitting. This is a self-locking fitting. Push and slightly turn the cut end of the air line into the fitting as far as it will go. You will hear or feel a definite click when the air line is seated. Air line should go in $\frac{9}{16}$ ". The air line is now installed.

Figure 5

IV. Installing the Air Line

1. Remove the air pressure from the air springs by taking the core out of the inflation valve, or by using a tire gauge to depress the core to bleed off the air pressure.
2. Use a standard tube cutter, a razor blade, or very sharp knife to cut the air line between the air spring and the inflation valve. A clean square cut will ensure against leaks. Install a tee. Repeat this step for other side (Figure 5).
3. Route air line between the two tees and connect to the last opening in each tee. **NOTE: Keep air line away from heat (exhaust system, etc.) and moving chassis components. Secure air line to the frame with nylon tie straps provided.**
4. Determine the location of the third tee. Cut the air line between the first two tees and install a third (Figures 1 & 5).
5. Measure the distance from the open tee to the compressor. Cut the air line to the proper length and install on the last leg of the tee installed between the air springs. Route the air line from the tee to the compressor along the frame and secure with nylon tie straps.
6. Install the air line into the air line fitting previously installed on the compressor (Figure 4).
7. Determine the closest and easiest area to connect the gauge panel to the air line between the compressor and air springs. Measure the distance between these two points and cut the air line and install the last tee (Figures 1 & 5).
8. Attach air line to the last leg of this tee and route the air line to the gauge panel. Attach the air line to the panel sliding it onto the barbed fitting on the panel until it fully covers all the barbs.
9. Turn on ignition switch. Push on/off switch and observe pressure increase on the air gauge (Figure 6). Inflate to maximum recommended pressure. Inspect each connection with a soap and water solution. If a leak is found in the fittings, reduce air pressure to zero and tighten threaded connections or remove air line, cut off one inch and reattach.

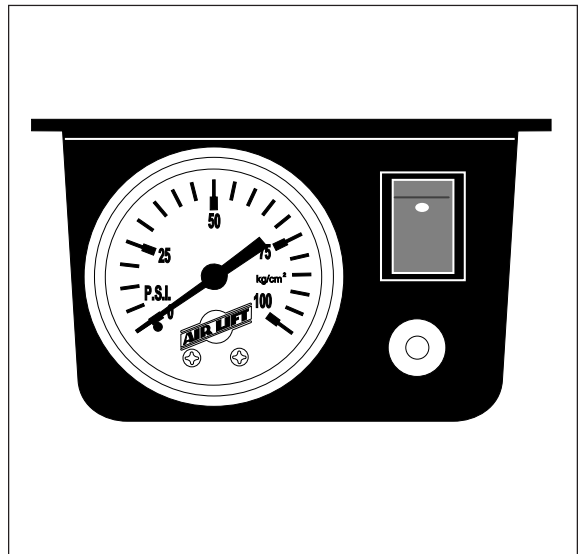

Figure 6

V. Inflation Control

1. Your vehicle is equipped with rear air springs. The following procedure is a “guide” to assist you in leveling your vehicle to provide the best possible ride and handling.
2. Fill the air springs to maximum recommended pressure. The pressure can be increased from the dash control or the inflation valves located just ahead of the rear wheels. Generally, the vehicle will ride best when the rear springs are slightly arched (if equipped with leaf springs). Start with a higher pressure and decrease in five pound increments to determine the best ride and handling for your particular vehicle. Increases in pressure can be made to compensate for additional load and trailers, etc. Higher pressures can be used when the vehicle is in storage to relieve the leaf springs.

VI. Operating Instructions

1. **IMPORTANT:** Do not exceed the recommended duty cycle of 15% (3 minutes on and 20 minutes off). Not complying with the recommended duty cycle may cause premature failure of the compressor.
2. The air springs should be inflated to the specified air pressure as discussed in the air spring inflation procedure.
3. When ever load and weight distribution change, simply adjust the pressure in the air springs to maintain a level vehicle. The air pressure is manually controlled by the control panel located on the dash.
4. To inflate the air springs and raise the vehicle, depress the switch on the control panel. The compressor will turn on automatically to increase the pressure as indicated on the gauge. Once the desired pressure is reached, release the switch and the compressor will shut-off.
5. To deflate the air springs, depress the button below the on/off switch (Figure 6).

VII. Troubleshooting

1. In the event that the compressor stops running, allow the compressor to cool down before running again and provide adequate time for the thermal breaker to reset before trying to start the compressor again.
2. Check the inflation pressure weekly, air spring bellows will permeate (loss of pressure through the rubber wall) at the approximate rate of 3–4 p.s.i. per week. Leakage at a higher rate indicates a leak. In order to find a possible leak, inflate the system to the maximum recommended pressure and spray all fittings with soapy water solution.
 - a. Check the inflation valve, including the valve core and air line connections.
 - b. Check the elbow fitting where threaded into the bellows (all threaded connections must have pipe sealant applied) and the air line connection.

CAUTION: Do not exceed the recommended duty cycle of 15% (3 minutes on, 20 minutes off). Not complying with the recommended duty cycle may cause premature failure of the compressor.

CAUTION: Do not exceed the vehicle manufacturers maximum gross vehicle weight rating (GVWR).

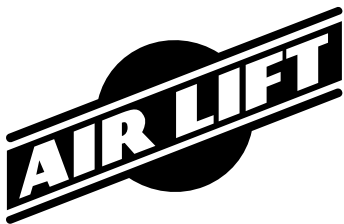

Thank you for purchasing Air Lift Products

Mailing Address:
AIR LIFT COMPANY
P.O. Box 80167
Lansing, MI 48908-0167

Street Address:
AIR LIFT COMPANY
2727 Snow Rd.
Lansing, MI 48917

Local Phone: (517) 322-2144
Fax: (517) 322-0240

For Technical Assistance call 1-800-248-0892

“The Choice of the Professional Installer”

Printed in the USA