

Please read these instructions completely before proceeding with the installation.

IMPORTANT: Always keep safety in mind when working on your vehicle.

I. Preparing the Vehicle

1. Jack up rear of vehicle or raise on hoist. Support frame with safety stands.
2. The coil springs must be removed for installation:
 - a. Detach the shock absorbers at the lower shock mount (Figure 2).
 - b. Detach the panhard rod at the lower axle mount (Figure 2).
 - c. If there is a rear anti-sway bar, you may have to disconnect the links.
 - d. Mark the position of the coil spring on the upper spring seat so that the spring can be reinstalled in the same position.
 - e. Carefully lower the axle until the coil springs are free.

CAUTION: Do not strain brake lines. Disconnect brake line brackets if necessary. Remove coil springs.

3. There is a large jounce bumper at the top of the coil spring (Figure 1). Trim the jounce bumper as specified in Figure 3.
4. Drill the small hole in the lower spring seat out using a 9/16" drill bit or grind with a die grinder for hose access to cylinder.
5. Insert the cylinders into the springs with the stem pointing downward. Install the springs back onto the vehicle's rear suspension. Add one round protector on the stem side (bottom) of the cylinder (Figure 4). Line up the mark previously made to align the air spring into position.
6. Select either Dual Air Line or Tee Air line option depending on use of vehicle. The tee airline installation is best for vehicles that are loaded evenly from side to side. The dual air line installation should only be used if vehicle will have an unbalanced side to side loading; i.e. considerably more load on left side than right, or vice versa. Depending on your chosen installation, proceed with I (tee) or II (dual).

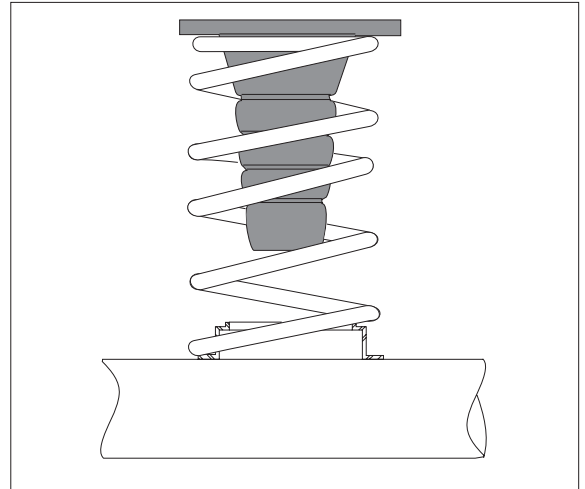

Figure 1

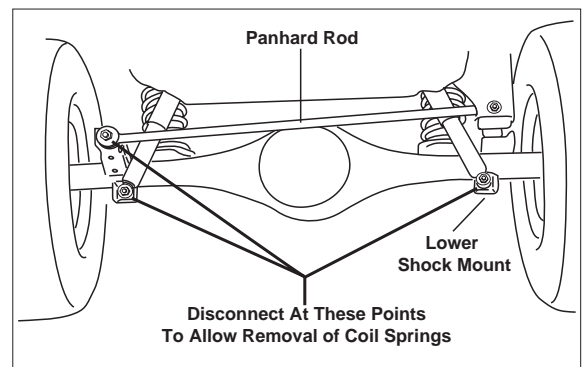

Figure 2

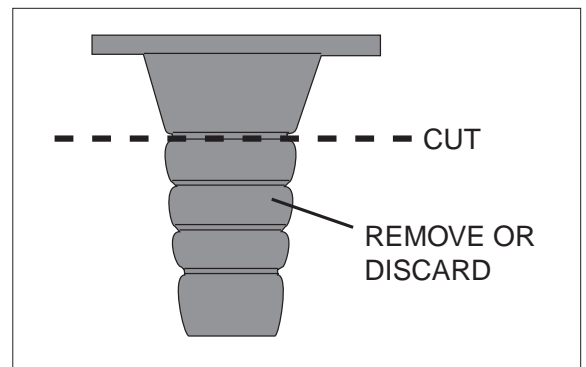

Figure 3

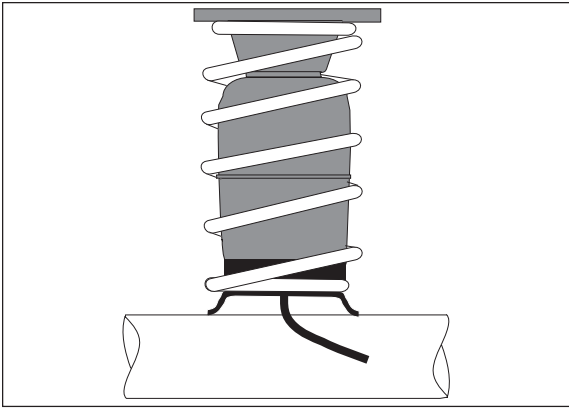

Figure 4

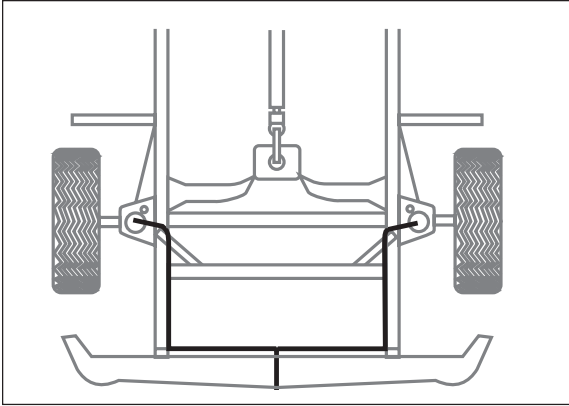

Figure 5

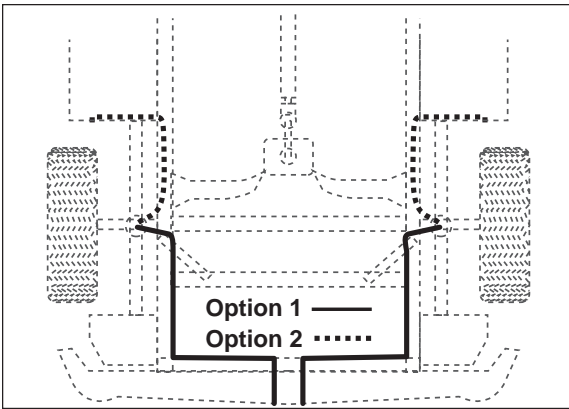

Figure 6

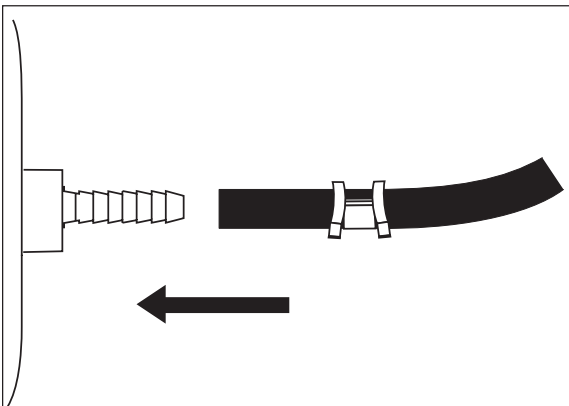

Figure 7

II. Tee Air Line Routing

TO PREVENT AIR LINE FROM MELTING, KEEP IT AT LEAST EIGHT INCHES FROM EXHAUST SYSTEM.

- A. Locate desired tee location on the frame rail or cross member.
- B. Determine and cut adequate length of air line to reach from tee to left and right side on air cylinders.

CAUTION: LEAVE SUFFICIENT AIR LINE SLACK TO PREVENT ANY STRAIN ON FITTING DURING AXLE MOTIONS.

- C. Slide air line clamp onto the air line.
- D. Push the air line over one side of the tee until all the barbs are covered. With pliers slide the air line clamp forward until it fully covers the barbed section. Repeat procedure for other leg of tee (Figure 8).
- E. Route air line along cross member and upper spring seat to air cylinder (Figure 5).
- F. Insert air line through spring seat and protector (Figure 4).
- G. Slide air line clamp onto the air line. Push the air line onto the stem, covering all the barbs (Figure 7). With pliers slide the air line clamp upward until it fully covers the barbed section. Repeat for the other side.
- H. Push the remaining air line over the last fitting on tee and route along frame to desired inflation valve location (Figure 5). Attach with plastic straps.
- I. Select a location for inflation valve in the gas cap well, the trunk, rear bumper, fender flange or behind the license plate, insuring that the valve will be protected and accessible with an air hose.
- J. Drill a 5/16" hole for inflation valve and mount as in illustration (Figure 9). Rubber washer is for outside weather seal.
- K. Slide air line clamp over the air line. Push air line onto fitting covering all barbs, with pliers slide the air line clamp forward until it fully covers the barbed section (Figure 10).
- L. Continue with step 7, page 4.

DO NOT INFLATE AIR CYLINDERS BEFORE READING MAINTENANCE & OPERATING TIPS.

III. Dual Air Line Routing

TO PREVENT AIR LINE FROM MELTING, KEEP IT AT LEAST EIGHT INCHES FROM EXHAUST SYSTEM.

- A. Select a location for the inflation valves in the rocker panel flange, or rear bumper, assuring that each valve will be protected and accessible with an air hose (Figure 6).
- B. Determine and cut adequate length of air line to reach from valve location to left side air cylinder.

CAUTION: LEAVE SUFFICIENT AIR LINE SLACK TO PREVENT ANY STRAIN ON VALVE STEM DURING NORMAL AXLE MOTIONS.

- C. Insert the air line through the spring seat and protector (Figure 4).
- D. Slide air line clamp onto the cut air line.
- E. Push the air line onto the stem, covering all the barbed section (Figure 7). With pliers slide the air line clamp forward until it fully covers barbed section.
- F. Repeat process for right side.
- G. Drill 5/16" hole for inflating valves and mount as illustrated. Rubber washer is for outside weather seal (Figure 9).
- H. Route air line along control arm and frame to inflation valve location and cut off excess.
- I. Slide a clamp onto the air line and push the air line over the fitting, covering all the barbs. With pliers slide the air line clamp forward until it fully covers the barbed section (Figure 10).

- J. Continue with step 7.

DO NOT INFLATE AIR CYLINDERS BEFORE READING MAINTENANCE & OPERATING TIPS.

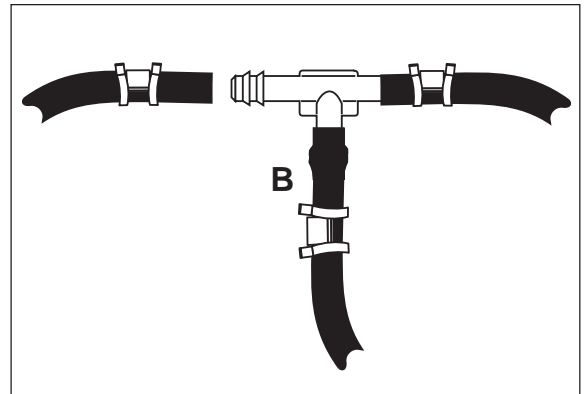

Use this procedure for all air line connections:
 A. Slide air line clamp onto the air line.
 B. Push the air line over the barbed stem.
 C. Compress the ears on the air line clamp with pliers and slide it forward to fully cover the section.

Figure 8

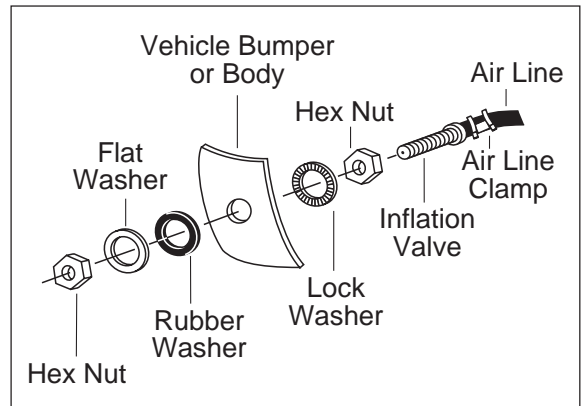

Figure 9

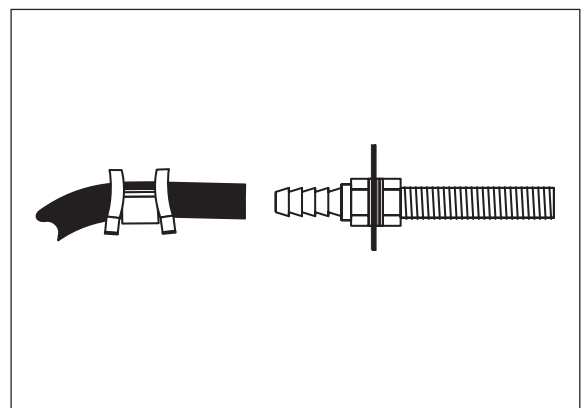

Figure 10

7. Reattach all components disconnected in step 2:
 - a. Reconnect brake lines to mounting brackets on rear axle and swaybar link if removed.
 - b. Reconnect panhard rod.
 - c. Reconnect shock absorbers.
 - d. Raise axle completely making sure air line going into cylinder does not get pinched.
8. Inflate Air Springs to 35 psi. Check for air leaks at all fittings and valve core with a soapy water solution.
9. Replace wheels, remove safety stands and carefully lower vehicle to ground.
10. Deflate Air Springs in 5 psi intervals to determine best ride and handing. Sufficient air pressure should be maintained to help prevent bottoming-out on large bumps, chuck holes, etc.
11. Recheck air pressure after 24 hours. A 2-4 psi loss is normal after initial installation. If the pressure has dropped more than 5 psi re-test for leaks with a soapy water solution. Please read and follow the Maintenance and Operation Tips on page 4.

Minimum Air Pressure	Maximum Air Pressure
5 p.s.i.	35 p.s.i.

Failure to maintain minimum pressure will void the warranty.

IV. Testing the Air Springs

1. Inflate the cylinders to 35 lbs of air pressure. Test for air leaks by applying a liquid solution of $\frac{1}{5}$ dish soap to $\frac{4}{5}$ water to all valve cores, fittings, and connections.
2. Lower the vehicle to the ground and deflate the air springs in 5 p.s.i. intervals to determine best ride and handling.
3. Recheck air pressure after 24 hours. A 2-4 p.s.i. loss after initial installation is normal. If pressure has dropped by more than 5 lbs, then retest for leaks with the soapy water solution.

V. Maintenance

1. Check air pressure weekly.
2. Always maintain at least a 5 p.s.i. air pressure chafing or coil pinch.
3. If a leak develops in the system, use a soapy water solution to check all air line connections and valve cores before removing the cylinder.



Thank you for purchasing Air Lift Products

Mailing Address:
 AIR LIFT COMPANY
 P.O. Box 80167
 Lansing, MI 48908-0167

Street Address:
 AIR LIFT COMPANY
 2727 Snow Rd.
 Lansing, MI 48917

Local Phone: (517) 322-2144
 Fax: (517) 322-0240

For Technical Assistance call 1-800-248-0892

“The Choice of the Professional Installer”

Printed in the USA