

SuperDUTY

by AIR LIFT®

**No. 57295,
57296, 57297**

***Dodge 2500/3500
2WD & 4WD***



INSTALLATION GUIDE

For maximum effectiveness and safety, please read these instructions completely before proceeding with installation.

Failure to read these instructions can result in an incorrect installation.

TABLE OF CONTENTS

Introduction	2
Important Safety Notice	2
Notation Explanation	2
Installation Diagram	3
Hardware List	3
Tools List	4
Installing the SuperDuty System	4
Raising the Vehicle	4
Removing the Jounce Bumper	4
Assembling the Air Spring	5
Attaching the Frame Upper Bracket	6
Attaching the Upper Bracket	6
Attaching the Lower Bracket	7
Installing the Heat Shield	7
Installing the Air Lines	8
Checking for Leaks	9
Fixing Leaks	9
Installation Checklist	10
Troubleshooting Guide	11
Maintenance and Servicing	11
Maintenance Guidelines	11
Warranty and Return Policy	12
Replacement Information	13
Contact Information	13

Introduction

The purpose of this publication is to assist with the installation, maintenance and troubleshooting of the SuperDuty air spring kit. SuperDuty utilizes sturdy, reinforced, commercial grade single or double, depending on the kit, convolute bellows. The bellows are manufactured like a tire with layers of rubber and cords that control growth. SuperDuty kits are recommended for most ¾ and 1 ton pickups and SUVs with leaf springs and provide up to 5,000 lbs of load leveling support with air adjustability from 5-100 p.s.i. The kits are also used in motorhome rear kits and some motorhome fronts where leaf springs are used.

It is important to read and understand the entire installation guide before beginning installation or performing any maintenance, service or repair. The information here includes a hardware list, tool list, step-by-step installation information, maintenance tips, safety information and a troubleshooting guide.

Air Lift Company reserves the right to make changes and improvements to its products and publications at any time. Go online to www.airliftcompany.com or contact Air Lift Company at (800) 248-0892 for the latest version of this manual.

IMPORTANT SAFETY NOTICE

The installation of this kit does not alter the Gross Vehicle Weight Rating (GVWR) or payload of the vehicle. Check your vehicle's owner's manual and do not exceed the maximum load listed for your vehicle.

Gross Vehicle Weight Rating: The maximum allowable weight of the fully loaded vehicle (including passengers and cargo). This number — along with other weight limits, as well as tire, rim size and inflation pressure data — is shown on the vehicle's Safety Compliance Certification Label.

Payload: The combined, maximum allowable weight of cargo and passengers that the truck is designed to carry. Payload is GVWR minus the Base Curb Weight.

NOTATION EXPLANATION

Hazard notations appear in various locations in this publication. Information which is highlighted by one of these notations must be observed to help minimize risk of personal injury or possible improper installation which may render the vehicle unsafe. Notes are used to help emphasize areas of procedural importance and provide helpful suggestions. The following definitions explain the use of these notations as they appear throughout this guide.

DANGER

INDICATES IMMEDIATE HAZARDS WHICH WILL RESULT IN SEVERE PERSONAL INJURY OR DEATH.

WARNING

INDICATES HAZARDS OR UNSAFE PRACTICES WHICH COULD RESULT IN SEVERE PERSONAL INJURY OR DEATH.

CAUTION

INDICATES HAZARDS OR UNSAFE PRACTICES WHICH COULD RESULT IN DAMAGE TO THE MACHINE OR MINOR PERSONAL INJURY.

NOTE

Indicates a procedure, practice or hint which is important to highlight.

Installation Diagram

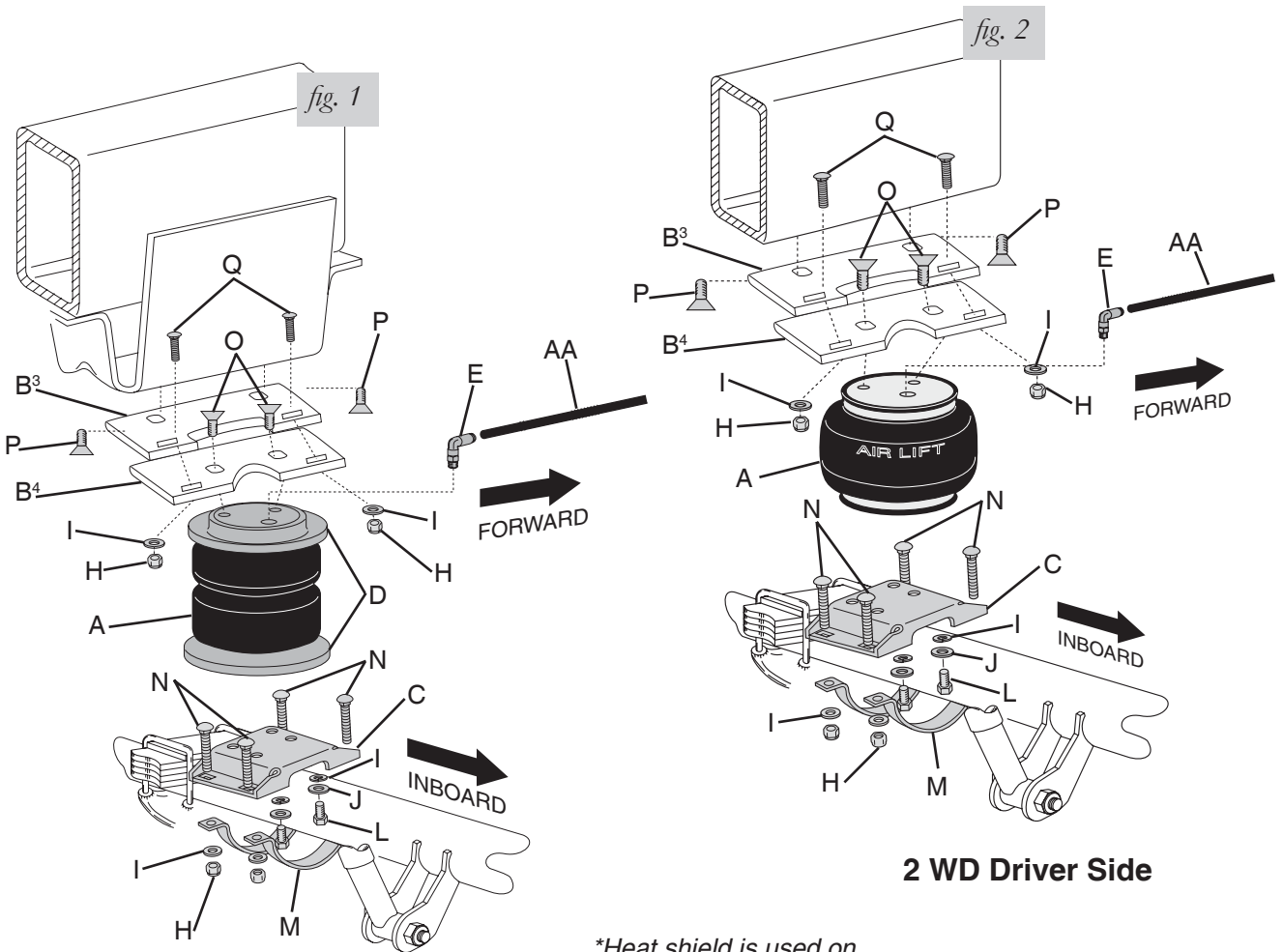

4 WD Driver Side

2 WD Driver Side

**Heat shield is used on the passenger side only.*

HARDWARE LIST

Item	Part #	Description.....Qty	Item	Part #	Description.....Qty
A ¹	58437	Bellow (57295)..... 2	L	17203	3/8" x 7/8" Hex head cap screw 4
A ²	58419	1B6 Bellow (57296)..... 2	M	01815	4" Axle strap..... 4
A ³	58407	1B6 Bellow (57297)..... 2	N	17277	3/8"-16 x 3 Carriage bolt 8
B ¹	07242	Right hand frame upper bracket 1	O	17215	3/8"-16 x 3/4 Flat head screw 4
B ²	07408	Right hand cylinder upper bracket 1	P	17360	M10-1.50 x 35 Flat head screw..... 4
B ³	07183	Left hand frame upper bracket..... 1	Q	17361	3/8"-16 x 1.25 Carriage bolt 4
B ⁴	07371	Left hand cylinder upper bracket..... 1	AA	20086	Air line assembly 1
C	03020	Lower bracket 2	*BB	10466	Tie strap 6
D	11951	Roll plates (4WD only) 4	*CC	21230	Valve caps 2
E	21837	Elbow fitting..... 2	*DD	18405	5/16" Flat washer 2
*F	09484	Thermal sleeve 1	*EE	21234	Rubber washer..... 2
*G	10613	Heat shield 1	*FF	18411	Small star washer 2
H	18436	3/8" Nyloc nut..... 12	*GG	21233	5/16" Hex nut 4
I	18444	3/8" Flat washer 12			
J	18427	3/8" Lock washer..... 4			
K	10741	Clamp #48-102 2			

*Not shown in diagram.

TOOLS LIST

Description.....	Qty	Description.....	Qty
7/16" and 9/16" Open-end or box wrenches.....	2	Standard and metric allen head wrenches.....	2
Crescent wrench.....	1	Hose cutter, razor blade, or sharp knife.....	1
Ratchet with 3/8", 9/16", & 1/2" deep well sockets.....	1	Hoist or floor jacks.....	1
3/8" and 5/16" drill bits (very sharp).....	1	Safety stands.....	1
3/8" Nut driver.....	1	Safety glasses.....	1
Heavy duty drill.....	1	Air compressor or compressed air source.....	1
Torque wrench.....	1	Spray bottle with dish soap/water solution.....	1

Installing the SuperDuty System

IMPORTANT SYSTEM INFORMATION

The air springs will last much longer if they are not the suspension limiter in either compression or extension. The air spring compresses to 2.8" and extends to 9.1". Regardless of the load, the air pressure should be adjusted so that the normal ride height is maintained at all times. The shock absorber is usually the limiter on extension. If this is not the case, the use of limiting straps should be considered, particularly for off-road vehicles.

CAUTION

A DISTANCE OF 4" OR GREATER MUST BE MAINTAINED BETWEEN THE UPPER AND LOWER BRACKET FOR KIT #57297 (2WD). ADD SUFFICIENT PRESSURE TO MAINTAIN THIS HEIGHT.

Your vehicle may be equipped with a rear brake proportioning valve. Any type of load assist product could affect brake performance. We recommend that you check with your dealer before installing this type of product. If your vehicle DOES NOT have a rear brake proportioning valve or is equipped with an anti-lock type brake system, installation of a load assist product will have NO EFFECT on brake system performance.

DANGER

COMPRESSED AIR CAN CAUSE INJURY AND DAMAGE TO THE VEHICLE AND PARTS IF IT IS NOT HANDLED PROPERLY. FOR YOUR SAFETY, DO NOT TRY TO INFLATE THE AIR SPRINGS UNTIL THEY HAVE BEEN PROPERLY SECURED TO THE VEHICLE.

REMOVING THE JOUNCE BUMPER

1. Raise the vehicle and support the axle with jack stands, setting the jack stands as wide as possible on the axle (fig. 3).
2. **2WD vehicles:** Remove the jounce bumpers from the bottom of the frame.
4WD vehicles: Remove the jounce bumpers from the jounce bumper bracket.

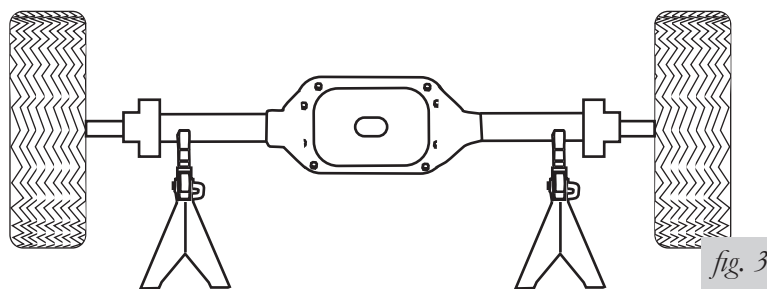

ASSEMBLING THE AIR SPRING

1. Set a roll plate (D) on both ends of the air spring (fig. 4). Four wheel drive models only.

NOTE

The radiused (rounded) edge of the roll plate will be towards the air spring so that the air spring is seated inside both roll plates (fig. 4).

2. Install a 90° swivel air fitting (E) finger tight plus 1½” turns (fig. 4). Use a 7/16” open end wrench. Be careful to tighten on the metal hex nut only. **DO NOT OVERTIGHTEN.** (This fitting is pre-coated with a sealant.)
3. Place the upper bracket (B² for right hand cylinder, B⁴ for left hand cylinder,) onto the top of the air spring. Attach the upper bracket (B² or B⁴) to the assembly using 3/8” flat head screws (O). Tighten securely (fig. 4).
4. Insert the carriage bolts through the holes in the lower bracket (C) (fig. 4).
5. Place the lower bracket on the air spring in an offset position (fig. 4).

NOTE

The bellows assembly will offset (overhang) the lower bracket. Make sure that the offset is on the air fitting side of the assembly.

6. Using the template provided at the end of the manual, determine the correct holes for mounting the bracket. Use the holes marked by an “B” for bellows mounting.
7. Attach the lower bracket to the assembly using 3/8” flat washer (J), 3/8” lock washers (I) and hex head bolts (L). Tighten securely.

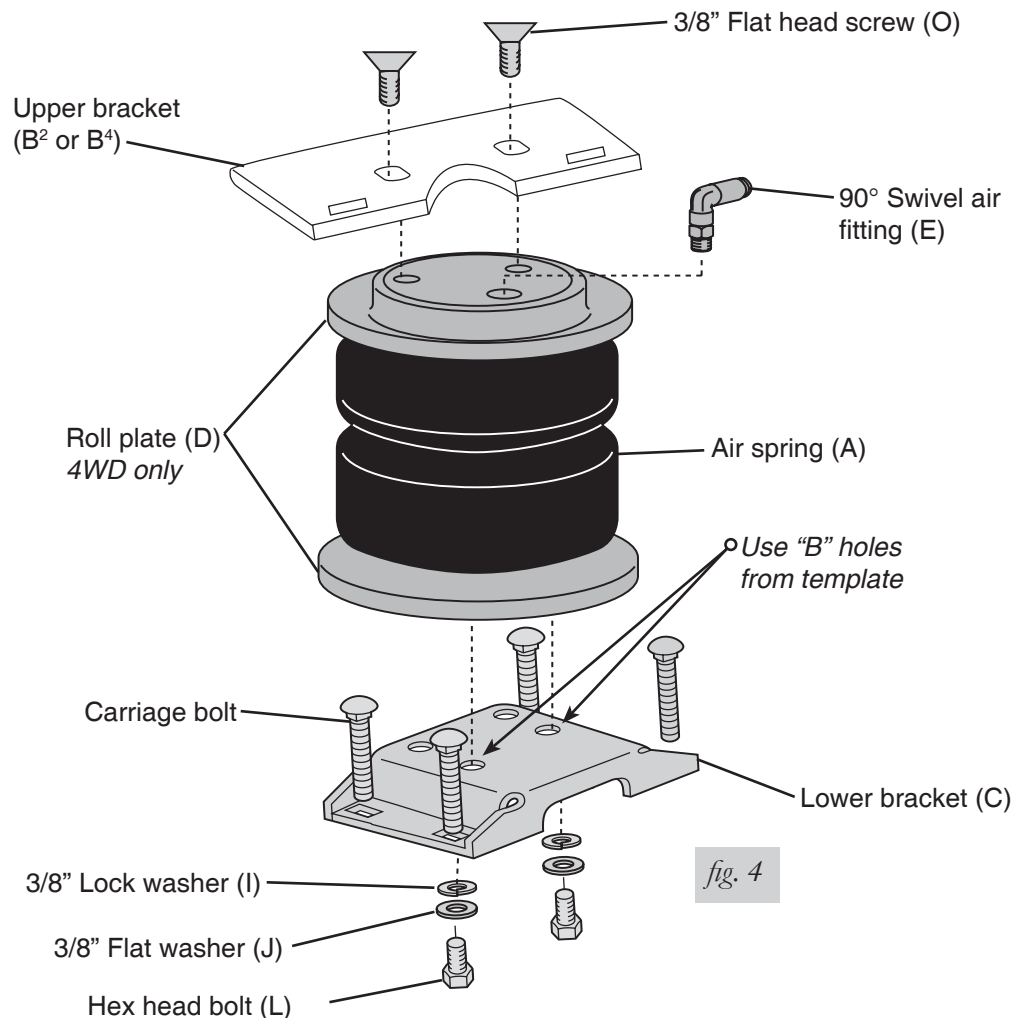

ATTACHING THE FRAME UPPER BRACKET

1. Attach the frame upper brackets, (B¹ for the right hand side and B³ for the left hand side,) to the frame using M-10 flat head screws (P). Tighten securely (fig. 5).

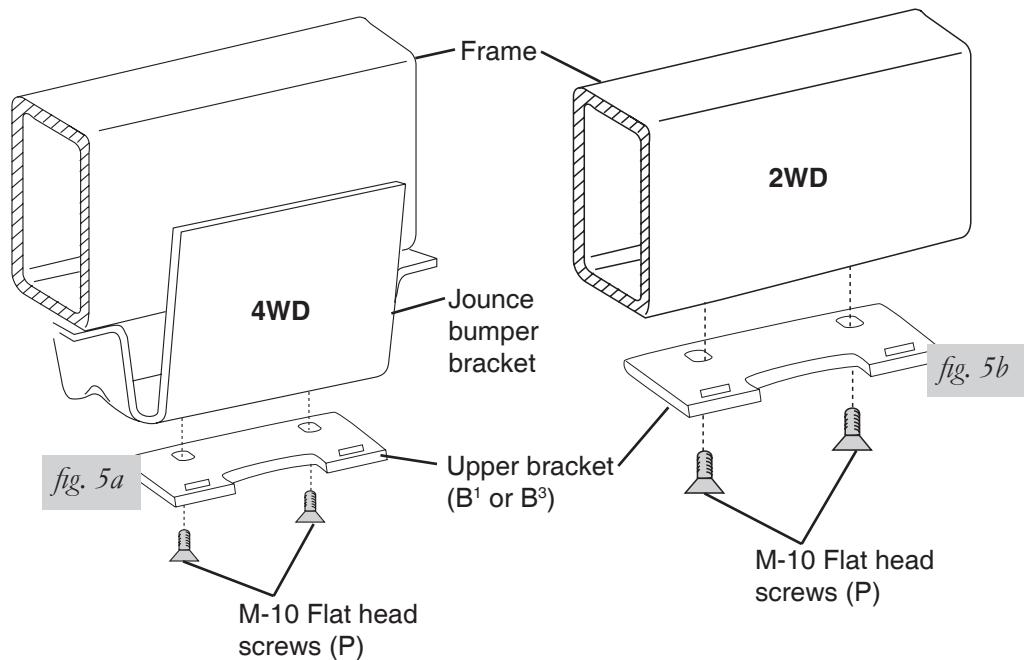

ATTACHING THE UPPER BRACKET

1. Set the assembly onto the axle with the 90° swivel air fitting pointing inward towards the center of the truck.

NOTE

If necessary, jack up the chassis to gain clearance to set the assembly into position.

2. Align the slots in the frame upper bracket and bellow upper bracket. Attach the two with the 3/8" carriage bolts (Q), flat washer (I) and nyloc nut (H) (fig. 6).
3. Push the top of the air spring forward or backward and align the upper and lower bracket so they are parallel.

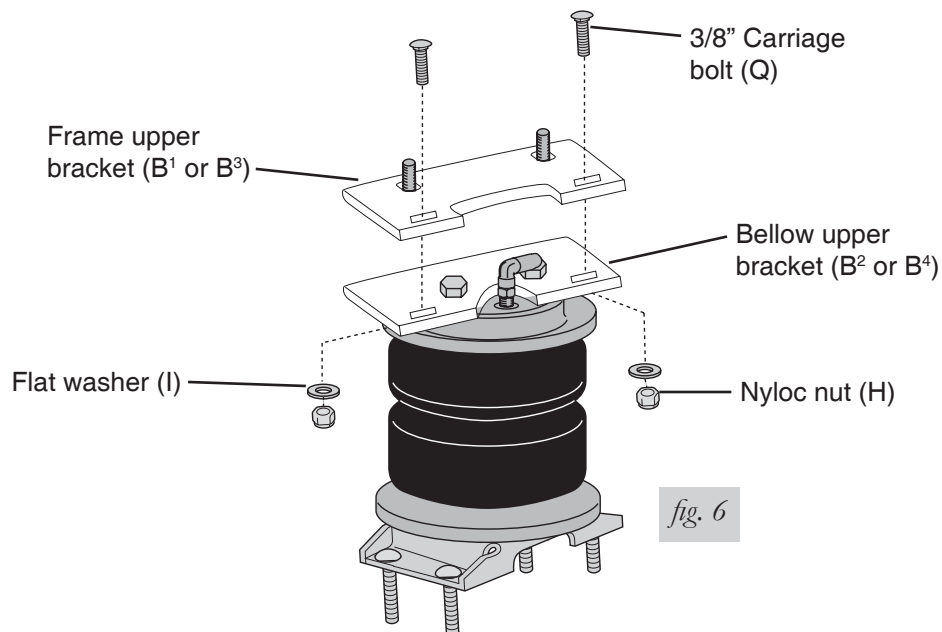

ATTACHING THE LOWER BRACKET

1. Secure the lower bracket to the axle using the axle straps (M), 3/8" flat washers (I), and 3/8" nyloc nuts (H) (fig. 7).

CAUTION

THE BRAKE LINE SITS UNDER THE BRACKET BETWEEN THE CARRIAGE BOLT AND THE AXLE ON THE INSIDE OF THE RIGHT HAND UNIT. THE OUTSIDE CARRIAGE BOLT GOES BETWEEN THE BRAKE LINE AND THE AXLE (FIG. 7).

NOTE

It may be necessary to re-position the brake line on the right and left hand sides to gain clearance.

2. Tighten the lock nuts evenly to 16 ft/lbs. Re-torque after 100 miles.
3. Repeat for the opposite side.

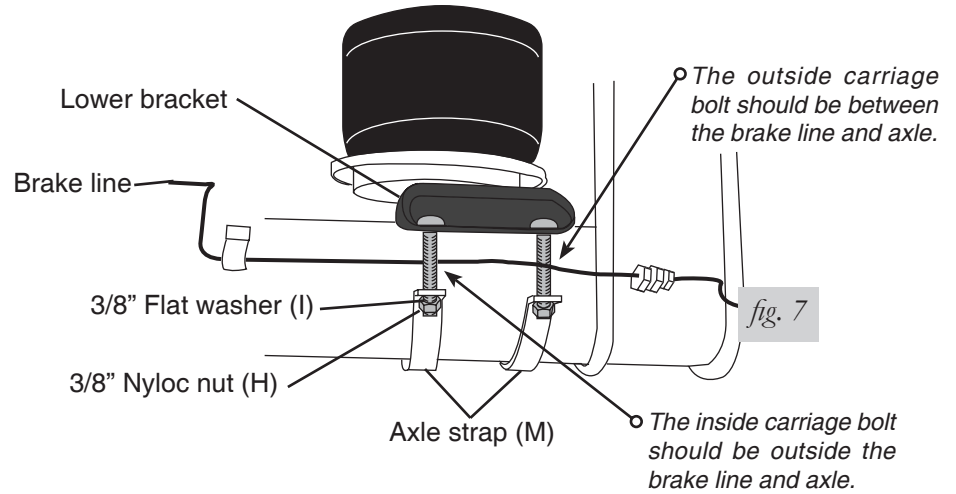

INSTALLING THE HEAT SHIELD

1. Bend the tabs on the heat shield (G) to provide a 1/2" of space between the exhaust pipe and the heat shield (fig. 8).
2. Attach the heat shield to the exhaust pipe using the provided clamps (fig. 9). Bend the heat shield for maximum clearance to the air spring.

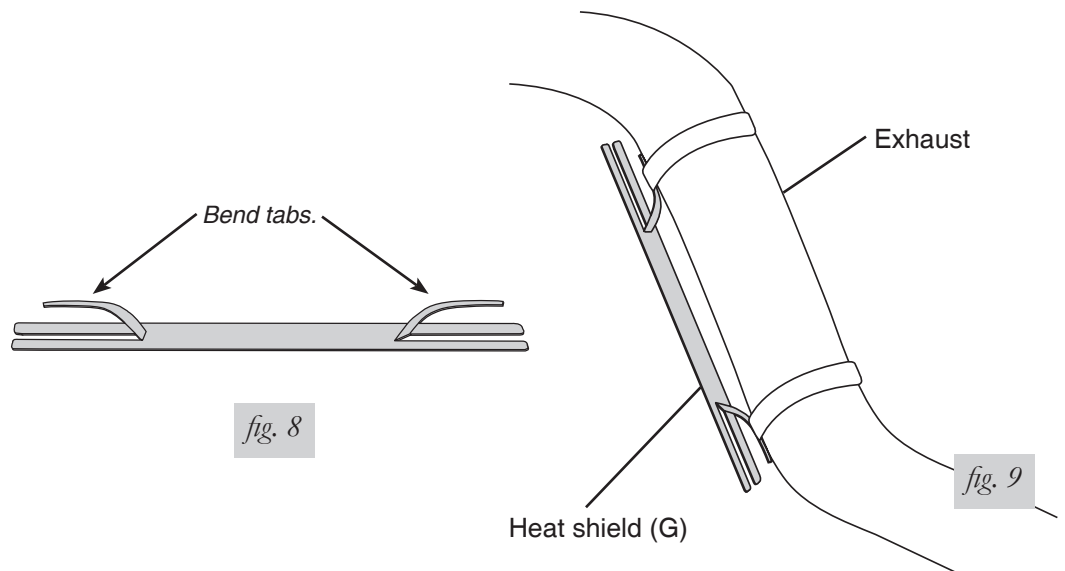

INSTALLING THE AIR LINES

1. Choose a convenient location for mounting the inflation valves. Popular locations for the inflation valve are:
 - a. The wheel well flanges
 - b. The license plate recess in bumper
 - c. Under the gas cap access door
 - d. Through the license plate

NOTE

Whatever the chosen location, make sure there is enough clearance around the inflation valves for an air chuck.

2. Drill two 5/16" holes to install the inflation valves.
3. Cut the air line assembly in two equal lengths.

CAUTION

WHEN CUTTING OR TRIMMING THE AIR LINE, USE A HOSE CUTTER, A RAZOR BLADE, OR A SHARP KNIFE. A CLEAN, SQUARE CUT WILL ENSURE AGAINST LEAKS. DO NOT USE WIRE CUTTERS OR SCISSORS TO CUT THE AIR LINE. THESE TOOLS MAY FLATTEN OR CRIMP THE AIR LINE CAUSING IT TO LEAK AROUND THE O-RING SEAL INSIDE THE ELBOW FITTING (FIG. 10).

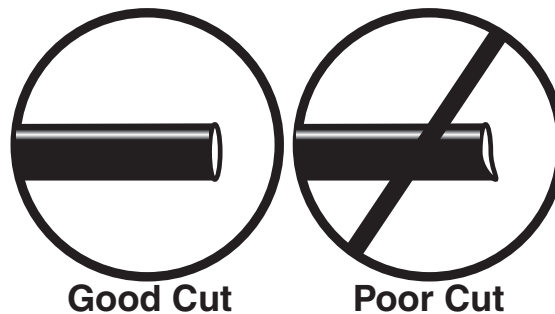

fig. 10

4. Place a 5/16" nut and star washer on the air valve. Leave enough of the inflation valve in front of the nut to extend through the hole and have room for the rubber washer, flat washer, and 5/16" nut and cap. There should be enough valve exposed after installation—approximately 1/2"—to easily apply a pressure gauge or an air chuck (fig. 11).
5. Push the inflation valve through the hole and use the rubber washer, flat washer, and another 5/16" nut to secure it in place. Tighten the nuts to secure the assembly (fig. 11).

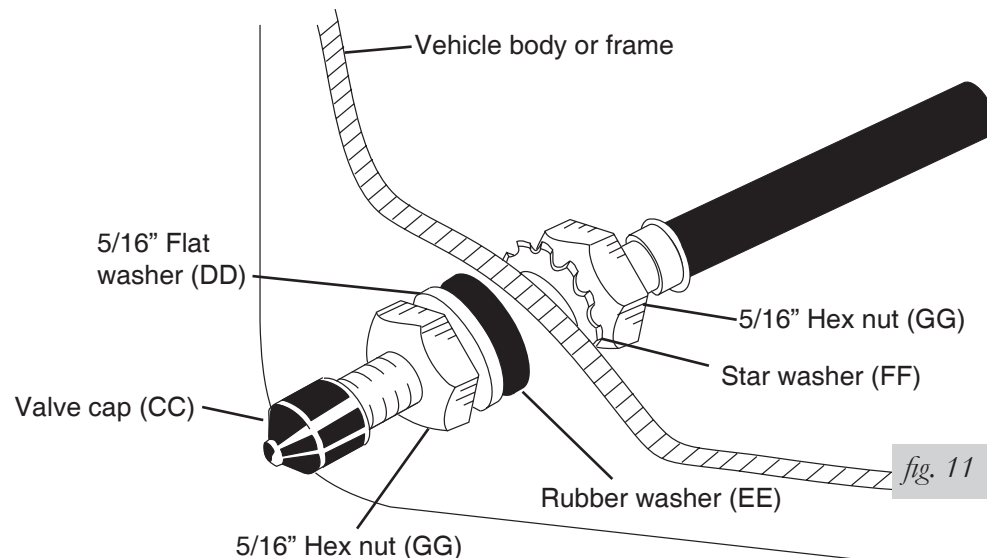

fig. 11

6. Route the air line along the frame to the air fitting on the air spring (fig. 12). Keep AT LEAST 6" of clearance between the air line and heat sources, such as the exhaust pipes, muffler, or catalytic converter. Avoid sharp bends and edges. Use the plastic tie straps to secure the air line to fixed, non-moving points along the chassis. Be sure that the tie straps are tight, but do not pinch the air line. Leave at least 2" of slack to allow for any movement that might pull on the air line.

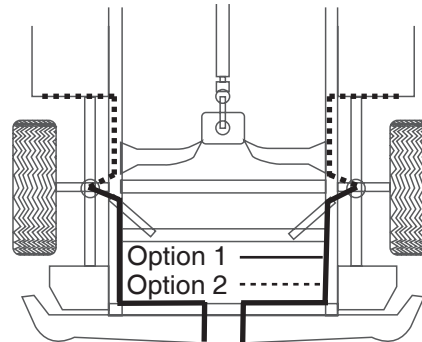

fig. 12

7. Cut off the air line, leaving approximately 12" of extra air line. A clean square cut will ensure against leaks (see fig. 10). Insert the air line into the air fitting. This is a push-to-connect fitting. Simply push the air line into the 90° swivel fitting until it bottoms out (9/16" of air line should be in the fitting).
8. Install the minimum/maximum air pressure decal in a highly visible location. We suggest placing the decal on the driver-side window, just above the door handle.

CHECKING FOR LEAKS

1. Inflate the air spring to 30 p.s.i.
2. Spray all connections and the inflation valves with a solution of 1/5 liquid dish soap and 4/5 water. Spot leaks easily by looking for bubbles in the soapy water.
3. After the test, deflate the springs to the minimum pressure required to restore the system to normal ride height. Do not deflate to lower than 10 p.s.i.
4. Check the air pressure again after 24 hours. A 2 - 4 p.s.i. loss after initial installation is normal. Retest for leaks if the loss is more than 5 lbs.

FIXING LEAKS

1. If there is a problem with the swivel fitting:
 - a. Check the air line connection by deflating the spring and removing the line by pulling the collar against the fitting and pulling firmly on the air line. Trim 1" off the end of the air line. Be sure the cut is clean and square (see fig. 10). Reinsert the air line into the push-to-connect fitting.
 - b. Check the threaded connection by tightening the swivel fitting another ½ turn. If it still leaks, deflate the air spring, remove the fitting, and re-coat the threads with thread sealant. Reinstall by hand tightening as much as possible and then use a wrench for an additional two turns.
2. If there is a problem with the inflation valve:
 - a. Check the valve core by tightening it with a valve core tool.
 - b. Check the air line by removing the air line from the barbed type fitting. Cut the air line off a few inches in front of the fitting and use a pair of pliers or vice grips to pull/twist the air line off of the fitting.

CAUTION

DO NOT CUT OFF THE AIR LINE COMPLETELY AS THIS WILL USUALLY NICK THE BARB AND RENDER THE FITTING USELESS.

3. If the preceding steps have not resolved the problem, call Air Lift customer service at (800) 248-0892.

Before Operating

INSTALLATION CHECKLIST (To be completed by installer)

- Clearance test — Inflate the air springs to 60 p.s.i. and ensure there is at least ½" clearance around each sleeve, away from anything that might rub against them. Be sure to check the tire, brake drum, frame, shock absorbers and brake cables.
- Leak test before road test — Inflate the air springs to 60 p.s.i., check all connections for leaks with a soapy water solution. See page 9 for tips on how to spot leaks. All leaks must be eliminated before the vehicle is road tested.
- Heat test — Be sure there is sufficient clearance from any heat sources — at least 6" for air springs and air lines. If a heat shield was included in the kit, install it. If there is no heat shield, but one is required, call (800) 248-0892.
- Fastener test — Recheck all bolts for proper torque. Axle straps carriage bolt lock nuts should be torqued to 16 ft/lbs. Re-torque after 100 miles.
- Road test — The vehicle should be road tested after the preceding tests. Inflate the air springs to 25 p.s.i. (50 p.s.i. if the vehicle is loaded). Drive the vehicle 10 miles and recheck for clearance, loose fasteners and air leaks.
- Operating instructions — If professionally installed, the installer should review the operating instructions on page 11 with the owner. Be sure to provide the owner with all of the paperwork which came with the kit.

Technician's Signature _____

Date _____

POST-INSTALLATION CHECKLIST (To be completed by owner)

- Overnight leakdown test — Recheck air pressure after vehicle has been used for 24 hours. If pressure has dropped more than 5 p.s.i., check for leaks and fix accordingly following the instructions on page 9 or return to the installer for service.
- Air pressure requirements — The air pressure requirements are detailed on page 11. Regardless of the load, the air pressure should always be adjusted so that normal ride height is maintained at all times.
- 30 day or 500 mile test — The air spring system must be rechecked after 30 days or 500 miles, whichever comes first. If any part shows signs of rubbing or abrasion, the source should be identified and moved, if possible. If it is not possible to relocate the cause of the abrasion, the air spring may need to be remounted. If professionally installed, the installer should be consulted. Check all fasteners for tightness.

Troubleshooting Guide

Problems maintaining air pressure, without an on-board compressor.

1. Leak test the air line connections and threaded connection of the elbow into the air spring. See "Fixing Leaks" on page 9 to repair.
2. Leak test the inflation valve for leaks at the air line connection or dirt debris in the valve core. See "Fixing Leaks" on page 9 to repair.
3. Inspect air lines to be sure no line is pinched. Tie straps may be too tight. Loosen or replace the strap. Replace leaking components.
4. Inspect the air line for holes and cracks. Replace as needed.
5. Check for a kink or fold in the air line. Reroute as needed.

Maintenance and Operations

Minimum Air Pressure	Maximum Air Pressure
5 p.s.i.	100 p.s.i.
FAILURE TO MAINTAIN CORRECT MINIMUM PRESSURE (OR PRESSURE PROPORTIONAL TO LOAD), BOTTOMING OUT, OVER-EXTENSION OR RUBBING AGAINST ANOTHER COMPONENT WILL VOID THE WARRANTY.	

MAINTENANCE GUIDELINES

NOTE

By following the steps below, vehicle owners will obtain the longest life and best results from their air springs.

1. Check the air pressure weekly.
2. Always maintain normal ride height. Never inflate beyond 100 p.s.i.
3. If you develop an air leak in the system, use a soapy water solution (1/5 liquid dish soap and 4/5 water) to check all air line connections and the inflation valve core before deflating and removing the air spring.

CAUTION

FOR YOUR SAFETY AND TO PREVENT POSSIBLE DAMAGE TO YOUR VEHICLE, DO NOT EXCEED MAXIMUM GROSS VEHICLE WEIGHT RATING (GVWR), AS INDICATED BY THE VEHICLE MANUFACTURER. ALTHOUGH YOUR AIR SPRINGS ARE RATED AT A MAXIMUM INFLATION PRESSURE OF 100 P.S.I., THE AIR PRESSURE ACTUALLY NEEDED IS DEPENDANT ON YOUR LOAD AND GVWR.

4. Loaded vehicles require at least 25 p.s.i. or more. A "loaded vehicle" refers to a vehicle with a heavy bed load, a trailer, or both. As discussed above, never exceed GVWR, regardless of air spring, air pressure, or other load assist. The springs in this kit will support approximately 40 lbs. of load (combined on both springs) for each 1 p.s.i. of pressure. The following chart can be used as a guideline for operating air pressure:

Load	Air Pressure
1000 lbs	25-35 p.s.i.
2000 lbs	45-55 p.s.i.
3000 lbs	70-80 p.s.i.
4000 lbs	90-100 p.s.i.

The previous chart is a general guideline only. Use enough pressure to level the vehicle to normal ride height recorded on page 11 of this manual. The required air pressure will vary depending on the state of the original suspension. Operating the vehicle below the minimum air spring pressure will void the Air Lift warranty.

5. When increasing load, always adjust the air pressure to maintain the normal ride height. Increase or decrease pressure from the system as necessary to attain normal ride height for optimal ride and handling. Remember that loads carried behind the axle (including tongue loads) require more leveling force (pressure) than those carried directly over the axle.
6. Always add air to springs in small quantities, checking the pressure frequently. Sleeves require less air volume than a tire and inflate quickly.
7. Should it become necessary to raise the vehicle by the frame, make sure the system is at minimum pressure (5 p.s.i.) to reduce the tension on the suspension/brake components. Use of on board leveling systems do not require deflation or disconnection.
8. Periodically check the air spring system fasteners for tightness. Also, check the air springs for any signs of rubbing. Realign if necessary.
9. On occasion, give the air springs a hard spray with a garden hose in order to remove mud, sand, gravel or other abrasive debris.

Warranty and Returns Policy

Air Lift Company warrants its products for the time periods listed on the next page to the original retail purchaser against manufacturing defects used on catalog listed applications on cars, vans, light trucks and motorhomes under normal operating conditions for as long as Air Lift manufactures the product. The warranty does not apply to products that have been improperly applied, installed, used in racing applications or not maintained in accordance with installation instructions furnished with all Air Lift products. The consumer will be responsible for removing (labor charges) the defective product from the vehicle and returning it, transportation costs prepaid to the dealer from which it was purchased or to Air Lift Company for verification.

Air Lift will repair or replace, at its option, defective products or components. A \$10.00 shipping and handling charge will apply to all warranty claims. Before returning any defective product, you must call Air Lift (800) 248-0892 U.S. and Canada for a Returned Materials Authorization (RMA) number. Returns to Air Lift can be sent to: Air Lift Company • 2727 Snow Road • Lansing, MI • 48917.

Product failures resulting from abnormal use or misuse are excluded from this warranty. The loss of use of the product, loss of time, inconvenience, commercial loss or consequential damages is not covered. The consumer is responsible for installation/reinstallation (labor charges) of the product. Air Lift Company reserves the right to change the design of any product without assuming any obligation to modify any product previously manufactured.

This warranty gives you specific legal rights and you may also have other rights that may vary from state to state. Some states do not allow limitations on how long an implied warranty lasts or allow the exclusion or limitation of incidental or consequential damages. The above limitation or exclusion may not apply to you. There are no warranties, expressed or implied including any implied warranties of merchantability and fitness, which extend beyond this warranty period. There are no warranties that extend beyond the description on the face hereof. Seller disclaims the implied warranty of merchantability. (*Dated proof of purchase required.*)

Air Lift 1000*	2 Year Limited	RideControl Plus*	2 Year Limited
SureSet*	2 Year Limited	Load Controller (I)*	2 Year Limited
Super Duty*	2 Year Limited	SmartAir*	2 Year Limited
Other Accessories	2 Year Limited	Load Controller (II)*	2 Year Limited
RideControl*	2 Year Limited	EasyStreet Systems	1 Year Limited
SlamAir	2 Year Limited	RoadTamer Systems	2 Year Limited

**The purchase of an Air Lift Load Controller II, SmartAir Automatic Leveling System or SureSet Load Controller System with a Super Duty, RideControl, or Air Lift 1000 extends the air springs' warranty from two years to a Limited Lifetime Warranty to the original purchaser of the covered systems. All other above listed warranty requirements will apply. (RoadTamer and EasyStreet air spring systems are excluded from this offer.)*

Replacement Information

If you need replacement parts, contact the local dealer or call Air Lift customer service at (800) 248-0892. Most parts are immediately available and can be shipped the same day.

Contact Air Lift Company customer service at (800) 248-0892 first if:

- Parts are missing from the kit.
- Need technical assistance on installation or operation.
- Broken or defective parts in the kit.
- Wrong parts in the kit.
- Have a warranty claim or question.

Contact the retailer where the kit was purchased:

- If it is necessary to return or exchange the kit for any reason.
- If there is a problem with shipping if shipped from the retailer.
- If there is a problem with the price.

Contact Information

If you have any questions, comments or need technical assistance contact our customer service department by calling (800) 248-0892, Monday through Friday, 8 a.m. to 5 p.m. Eastern Time. For calls from outside the USA or Canada, our local number is (517) 322-2144.

For inquiries by mail, our address is PO Box 80167, Lansing, MI 48908-0167. Our shipping address for returns is 2727 Snow Road, Lansing, MI 48917.

You may also contact us anytime by e-mail at sales@airliftcompany.com or on the Web at www.airliftcompany.com.

Lower bracket
mounting template.
See "Assembling the
Air Spring," pg. 5.

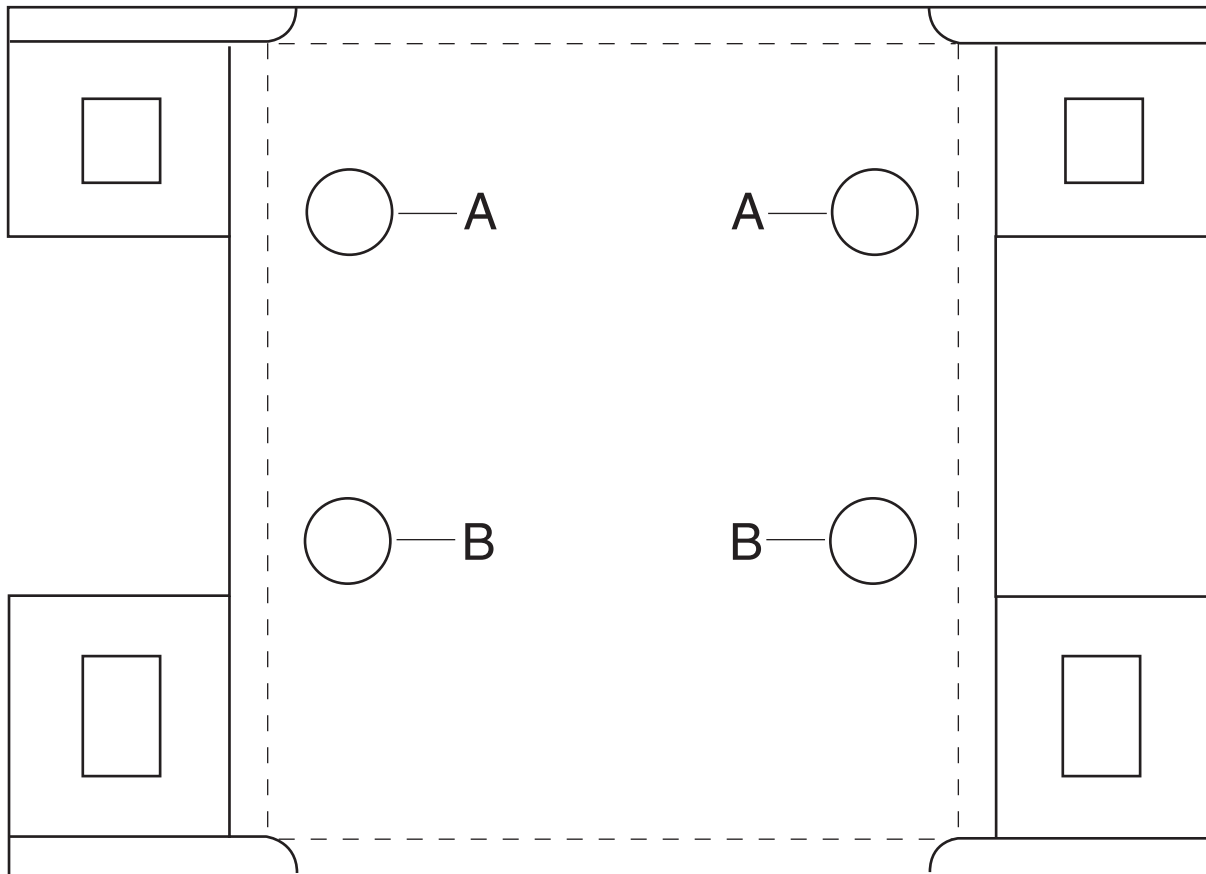

Need Help?

Contact our customer service department by calling (800) 248-0892, Monday through Friday, 8 a.m. to 5 p.m. Eastern Time. For calls from outside the USA or Canada, our local number is (517) 322-2144.

**Register your warranty online at
www.airliftcompany.com/warrantyreg.htm**



Thank you for purchasing Air Lift products — the professional installer's choice!

Air Lift Company • 2727 Snow Road • Lansing, MI 48917 or PO Box 80167 • Lansing, MI 48908-0167
Toll Free (800) 248-0892 • Local (517) 322-2144 • Fax (517) 322-0240 • www.airliftcompany.com

Printed in
the USA