

# AIR LIFT 1000

ADJUSTABLE AIR SPRING SUSPENSION



MN-439  
(04606)  
ECR 5715

Kit No. 60740

Please read these instructions completely before proceeding with the installation.

## AIR SPRING KIT PARTS LIST

Item	Part number	Description	Quantity
A	46160	Air Spring	2
B	34365	Heat Shield Kit	1

A



B



## AIR LINE ASSEMBLY PARTS LIST

Item	Part number	Description	Quantity
AA	20315	Air Line Assembly	15'
BB	10466	Tie Strap	6
CC	21230	Valve Caps	2
DD	18405	5/16" Flat Washer	2
EE	21234	Rubber Washer	2
FF	18411	Star Washer	2
GG	21233	5/16" Hex Nut	4
HH	21236	Plastic Tee	1
JJ	10638	Line Clips	6
KK	21455	Inflation Valve	2

AA



BB



CC



DD



EE



FF



GG



HH



JJ



KK

## TOOLS NEEDED

Open-end or box wrenches  
Pliers  
Drill and  $\frac{5}{16}$ ",  $\frac{1}{2}$ ", and  $\frac{3}{4}$ " bit  
Sharp Knife  
Aluminum Shears  
File, Air Grinder, Dremmel Tool

Hoist or Floor Jacks  
Safety Stands  
Safety Glasses  
Air Compressor, or Compressed Air Source  
Spray Bottle with Dish Soap/Water Solution

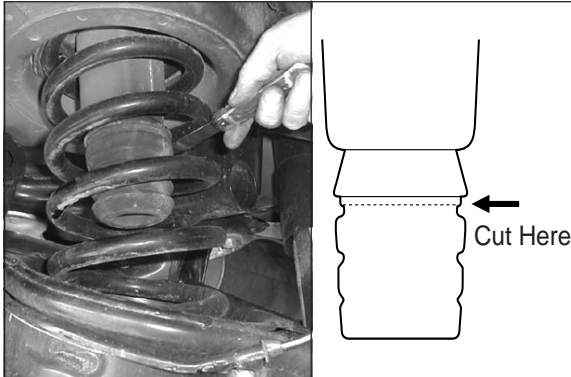

Figure 1



Figure 2



Figure 3



Figure 4

## I. REMOVING THE JOUNCE BUMPER

1. Jack up the rear of the vehicle. Put safety stands under the frame so wheels hang. Removing bottom shock bolt may aid in lowering suspension. Caution: Observe brake line, do not over extend.

2. Cut jounce bumper off  $\frac{1}{8}$ " under the steel cup where the rubber jounce bumper is attached. See illustration and Figure 1.

*CAUTION: Be extremely careful cutting jounce bumper off. A screw driver may aid in opening the jounce bumper up while cutting it off (Figure 2).*

3. Once the jounce bumper is cut off, it is necessary to remove it. Use a spring spreader or cut the jounce bumper in two with shears or bandcutters (Figures 3 and 4).

## II. INSTALLING THE AIR BAG

1. Cut out the template provided, and stick it to the underside of the lower control arm, aligning the template so that the hole to be drilled is towards the inside of the vehicle. See Figure 5. (The template is on page 9 at the end of this manual.)



Figure 5

2. Center punch and drill a  $\frac{3}{4}$ " hole to provide valve stem clearance (Figure 6).

*NOTE: As an option, to a  $\frac{3}{4}$ " bit, the picture shows a  $\frac{1}{2}$ " bit. Hole can be ground out to  $\frac{3}{4}$ " by using an air grinder or dremmel tool.*

3. Remove cap from valve stem, and step on cylinder to remove air. With cylinder flat, replace cap and fold like a hot dog bun (Figure 7).



Figure 6

4. Insert into spring with stem pointing downward (Figure 8).

5. A flat, blunt instrument may aid in positioning cylinder inside the coil spring. Remove cap and let cylinder resume its molded shape. Push the cylinder down so the barbed stem protrudes through the hole drilled previously (Figure 9).



Figure 7



Figure 9



Figure 8

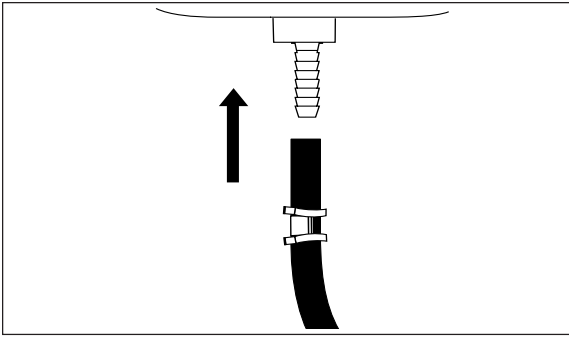

Figure 10



Figure 11

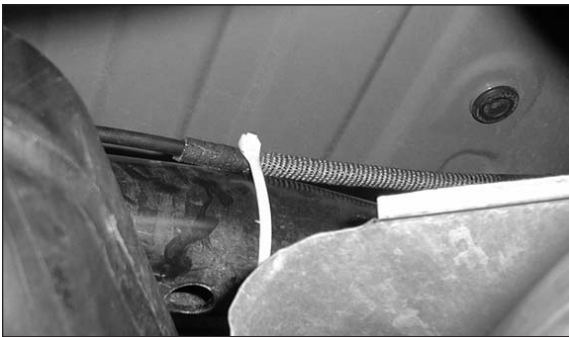

Figure 12



Figure 13



Figure 14

### III. INSTALLING THE AIR LINES

1. Slide one line clip (JJ) over one end of the hose. Insert hose onto barbed end of the cylinder. Using pliers, slide line clip over barbs (Figure 10).
2. Route hose up to cross member. Tie off with tie strap (BB) to existing hole forward of lower control arm (Figure 11).
3. Route line across to driver side, above cross member. Use hose heat shield (B) where line goes over exhaust (Figure 12).
4. Find a location on driver side for a tee. Route hose from passenger side to this location. Cut hose and install a line clip (JJ). Insert hose into one leg of tee (HH) and slide line clip over barbs. Repeat for driver side and attach to other side of tee (Figure 13).
 

**Note: You can opt to use a single line per bag, skip step 4 and, proceed to step 5.**
5. Determine a location for the inflation valve, (or valves) such as under the bumper (Figure 14). Route the remaining hose from this spot to the last leg of the tee and attach in the same manner.

6. Drill a  $\frac{5}{16}$ " hole for inflation valve, (or valves) and mount as illustrated (rubber washer is for outside weather seal). See Figure 15. Slide hose clip onto free end of remaining line, push line onto inflation valve and put on hose clip to secure line.

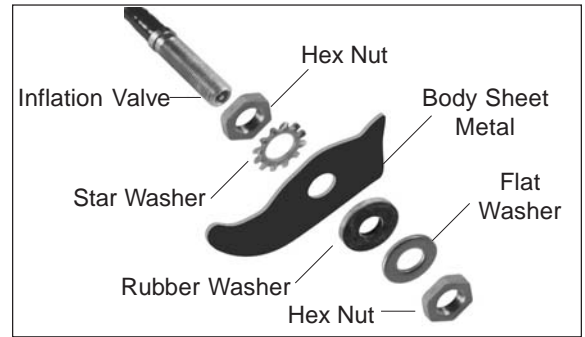

Figure 15

7. Bend heat shield tabs out at a 90° angle. Then bend again half the distance up at 90° angle to form an "L" shape. Position heat shield between spring and pipe. Clamp to pipe using radiator clamps (Figure 16).

*NOTE: There should be a dead airspace between exhaust pipe and heat shield (Figure 17).*



Figure 16

8. Inflate air springs to 10 p.s.i. Spray all connections and the inflation valves with a solution of  $\frac{1}{5}$  dish soap and  $\frac{4}{5}$  water to check for leaks. You should be able to spot leaks easily by looking for bubbles in the soapy water. Now adjust air pressure for optimal comfort and performance (minimum 5 p.s.i and maximum 35 p.s.i.).

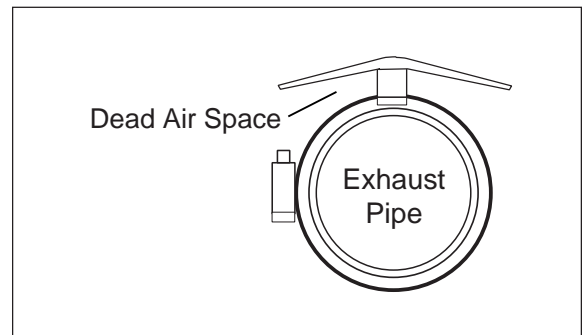

Figure 17

9. Check the air pressure again after 24 hours. A 2–4 p.s.i. loss after initial installation is normal. Retest for leaks if the loss is more than 5 p.s.i.

#### IV. TROUBLESHOOTING GUIDE

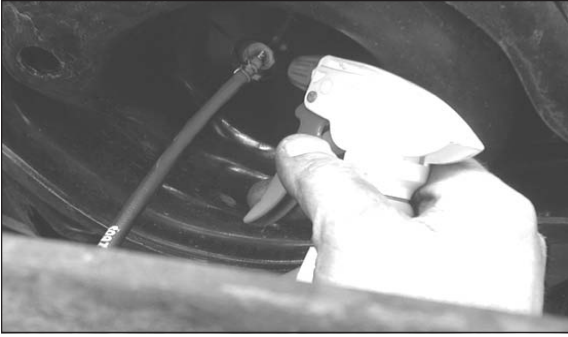

Figure 18

1. Leak test all the air line connections (Figure 18). Repair or replace as needed.

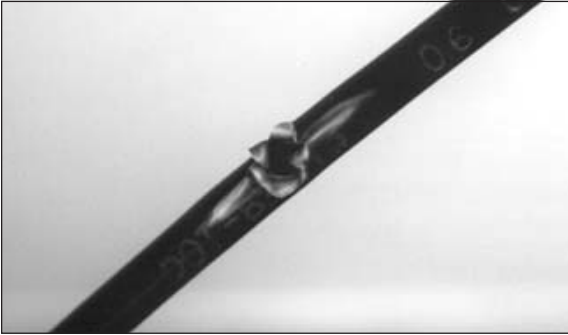

Figure 19

2. Inspect air line for holes and cracks (Figure 19). Replace as needed.

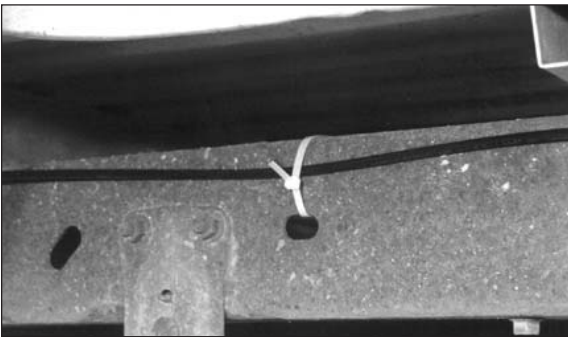

Figure 20

3. Inspect air lines to be sure it is not pinched. Tie straps may be too tight (Figure 20). Replace strap.



Figure 21

4. A kink or fold in the air line (Figure 21). Reroute as needed.

5. Leak test the inflation valve for leaks at the air line connection or dirt or debris in the valve core (Figure 22).



Figure 22

*You have now tested for all of the most probable leak conditions that can be easily fixed. At this point the problem is most likely a failed air spring - either a factory defect or an operating problem. Please call Air Lift at 1-800-248-0892 for assistance or a replacement air spring.*

## V. POST INSTALLATION CHECKLIST (TO BE COMPLETED BY OWNER)

- 1. Overnight Leakdown Test: Recheck air pressure after vehicle has been used for 24 hours. If pressure has dropped more than 5 p.s.i., there is a leak that must be fixed. Either fix the leak yourself or return to the installer for service.
- 2. Air Pressure Requirements: I understand that the air pressure requirements of my air spring system are as follows:

Minimum \_\_\_\_\_ Maximum \_\_\_\_\_

Exceeding the maximum recommended air pressure will result in the air spring “bulging out” between the coils of the spring which may cause the air spring to be pinched or may rub a hole into the cylinder.

## VI. MAINTENANCE AND OPERATIONS

<b>MINIMUM AIR PRESSURE</b>	<b>MAXIMUM AIR PRESSURE</b>
5 p.s.i.	35 p.s.i.

*By following these steps, vehicle owners should obtain the longest life and best results from their air springs.*

1. Check the air pressure in the air springs weekly.
2. Always maintain at least the recommended minimum air pressure to prevent the air spring from being pinched. Never inflate beyond the recommended maximum air pressure.
3. If you develop a leak in the system, use a soapy water solution to check all air line connections and the inflation valve core before deflating and removing the air spring.
4. Always add air to springs in small quantities, checking the pressure frequently. Air springs require less air volume than a tire and inflate quickly.



*View of the Final Installation*





# '99 - '00 Honda Odyssey Template

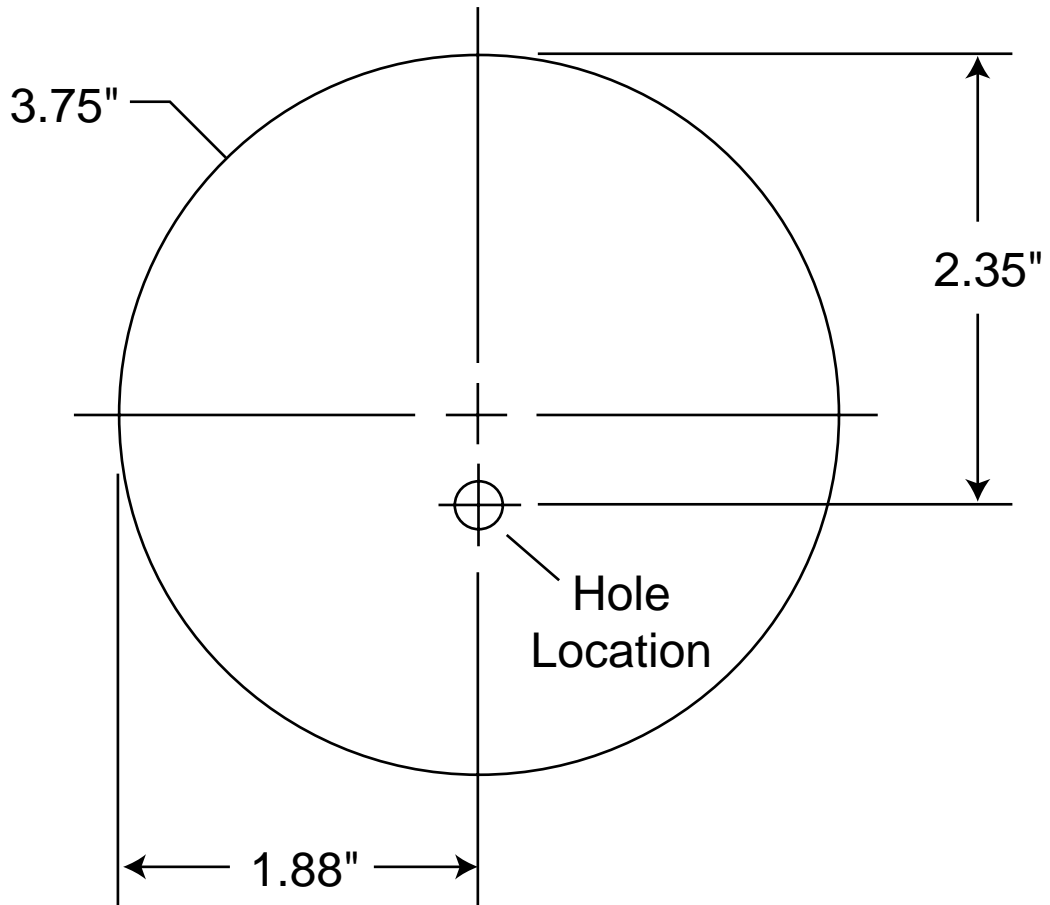



***Thank you for purchasing Air Lift Products***

Mailing Address:  
AIR LIFT COMPANY  
P.O. Box 80167  
Lansing, MI 48908-0167

Street Address:  
AIR LIFT COMPANY  
2710 Snow Rd.  
Lansing, MI 48917

Local Phone: (517) 322-2144  
Fax: (517) 322-0240

For Technical Assistance call 1-800-248-0892

*“The Choice of the Professional Installer”*

Printed in the USA