

Kit No. 60788

Please read these instructions completely before proceeding with the installation.

HARDWARE IDENTIFICATION

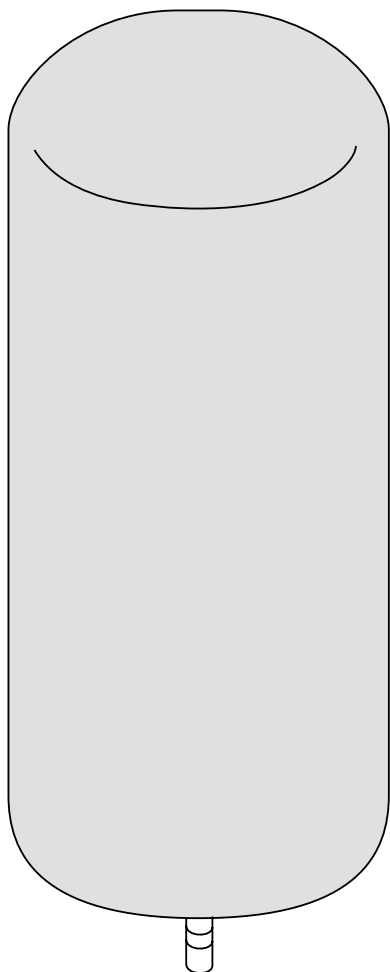

(2) 4" x 9" Cylinder

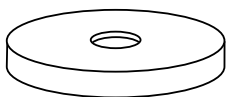

(2) Protector



(4) Self Tapping Bolts

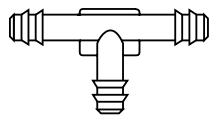

(1) Barbed Tee



(6) Air Line Clamp



(2) Poly Cap

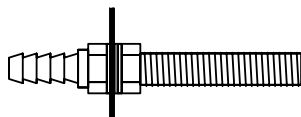

(2) Barbed Valve



(4) Hose Clip



(4) Hex Nut



(2) 5/16" Flat Washer



(2) Rubber Washer



(2) 5/16" Lock Washer

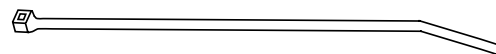

(10) Straps

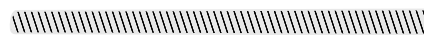

(2) Thermal Sleeve

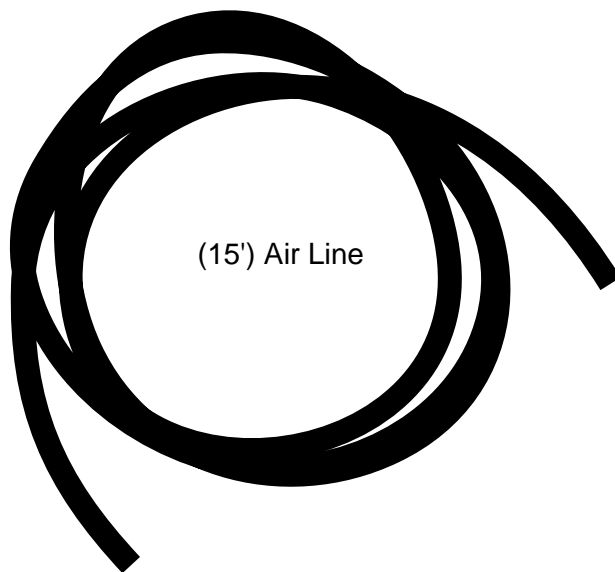

(15') Air Line

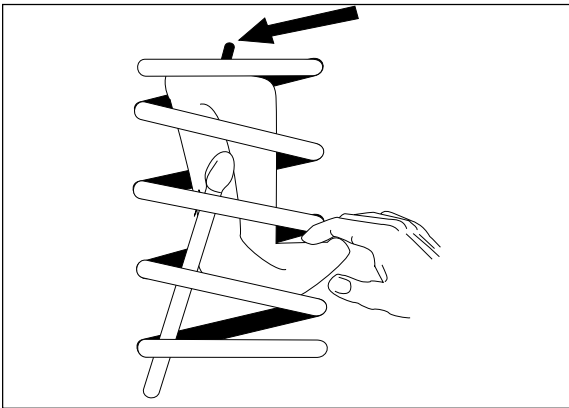

Figure 1

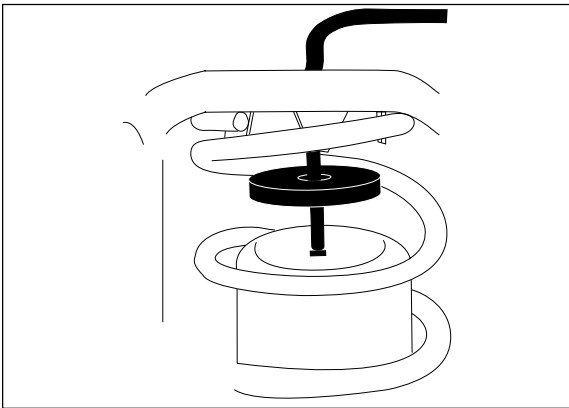

Figure 2

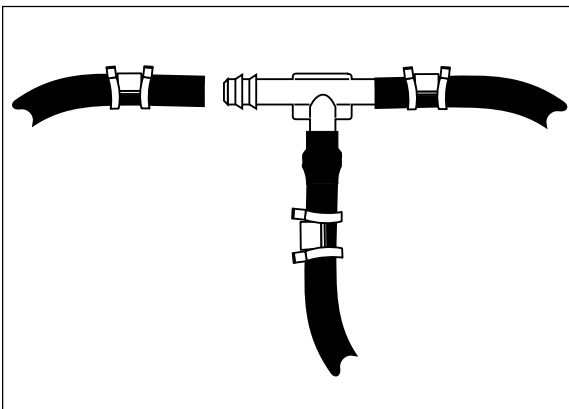

Figure 3

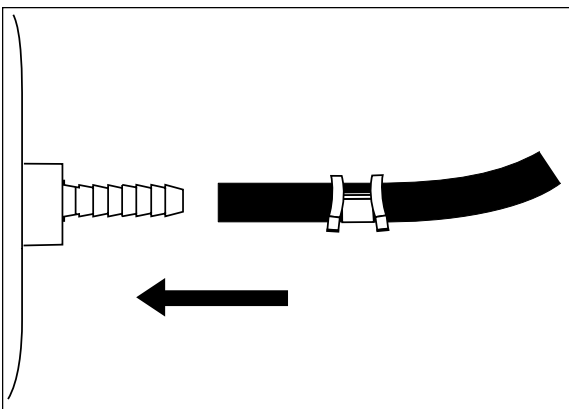

Figure 4

I. PREPARING THE VEHICLE

1. Jack up rear of vehicle or raise on hoist. Support frame with safety stands. Lower axle or raise body of vehicle until suspension is fully extended.
2. Remove plastic cap from barbed stem on end of cylinder. Exhaust the air from the cylinder by rolling it up toward barbed stem. Replace cap on stem to hold flat shape.
3. If necessary, additional clearance between the coil turns may be obtained by removing the shock absorbers from the lower shock mountings and lowering the suspension an additional one to two inches.

CAUTION: Observe tension on brake air line. Do not strain.

II. INSTALLING THE AIR CYLINDER

1. Insert flattened air cylinder into coil spring through lowest opening with stem at the top (Figure 1).
2. Push the cylinder up within the coil by hand or with a blunt instrument such as a spoon-type tire iron.
3. When the cylinder is completely within the coil, remove the cap and allow the cylinder to assume its "as molded" shape.
4. Push the cylinder to the bottom of the coil and insert protector at the top (Figure 2).

III. INSTALLING THE AIR LINES

Air tee line installation is recommended unless weight in vehicle varies from one side to the other and unequal pressures are needed to level the load. Dual air lines are used in this case.

1. Tee air line routing:

IMPORTANT: To prevent air line from melting, keep it at least 8" from the exhaust system. Use the two thermal sleeves provided on the air line in case the line runs close to the exhaust.

- a. Locate desired tee location on the frame rail or cross member.
- b. Determine and cut adequate length of air line to reach from tee to left and right side on air cylinders. *CAUTION: Leave sufficient air line slack to prevent any strain on fitting during axle motions.*
- c. Slide air line clamp onto the air line.
- d. Push the air line over one side of tee until all the barbs are covered. Repeat procedure for other leg of tee (Figure 3).
- e. With pliers slide the air line clamp forward until it fully covers the barbed section. Repeat for other leg of tee (Figure 3).
- f. Route along cross member. Snake hose through the frame behind springs and then to upper spring seat to air cylinder.
- g. Insert air line through spring seat.
- h. Push the air line onto the stem, covering all the barbs (Figure 4).

- i. With pliers slide the air line clamp downward until it fully covers the barbed section.
- j. Push the remaining air line over the last fitting on tee and route along frame to desired inflation valve location (Figure 5). Attach with plastic straps or use the supplied self tapping bolts with hose clips.
- k. Select a location for inflation valve in the gas cap well, the truck, rear bumper, fender flange or behind the license plate, insuring that the valve will be protected and accessible with an air hose.
- l. Drill a $\frac{5}{16}$ " hole for inflation valve and mount as in illustration (Figure 6). The rubber washer is for an outside weather seal.

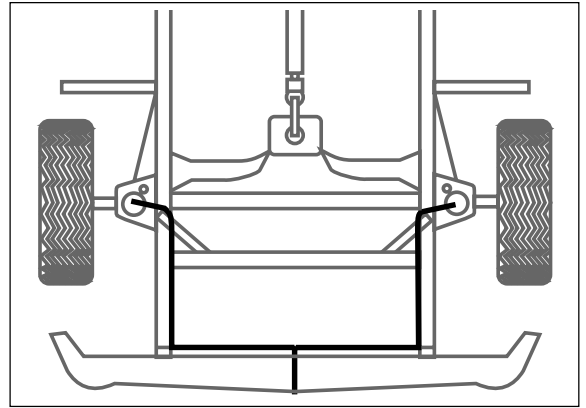

Figure 5

- m. Slide air line clamp over the air line. Push air line onto fitting covering all barbs, with pliers slide the air line clamp forward until it fully covers the barbed section (Figure 7).
- n. Raise axle or lower body until air cylinders lightly touch upper spring seat and lower spacers.
- o. Attach shock absorbers if removed earlier in the installation.

CAUTION: Do not inflate air cylinders before reading *Inflating the Air Springs* section.

- p. Continue with Section IV.

2. Dual air line routing:

IMPORTANT: To prevent air line from melting, keep it at least 8" from the exhaust system. Use the two thermal sleeves provided on the air line in case the line runs close to the exhaust.

- a. Select a location for the inflation valves in the rocker panel flange, or rear bumper, insuring that each valve will be protected and accessible with an air hose (Figure 8).
- b. Determine and cut adequate length of air line to reach from valve location to left side air cylinder. **CAUTION:** Leave sufficient air line slack to prevent any strain on valve stem during axle motions.

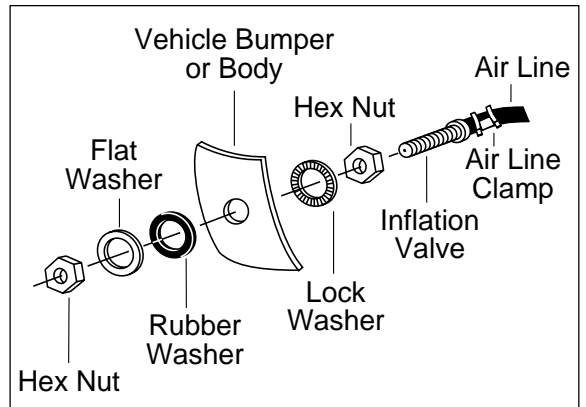

Figure 6

- c. Insert the air line through the spring seat and spacer. The hose will need to be snaked through the frame behind the springs.
- d. Slide air line clamp onto the cut air line.
- e. Push the air line onto the stem, covering all the barbed section (Figure 4).

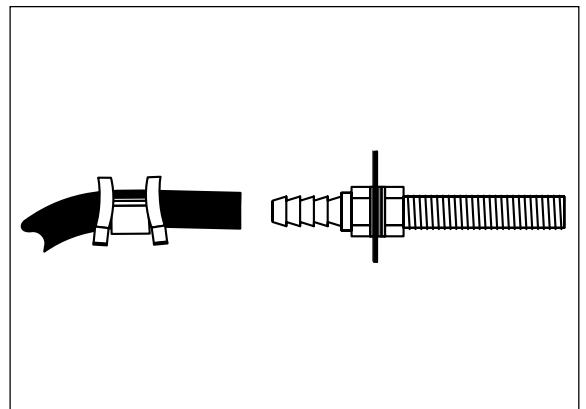

Figure 7

- f. With pliers slide the air line clamp down until it fully covers barbed section (Figure 4).
- g. Repeat process for right side.
- h. Drill $\frac{5}{16}$ " hole for inflation valves and mount as illustrated. The rubber washer is for an outside weather seal (Figure 6).
- i. Route air line along control arm and frame to inflation valve location and cut off excess.
- j. Slide a clamp onto the air line and push the air line over the fitting, covering all the barbs.

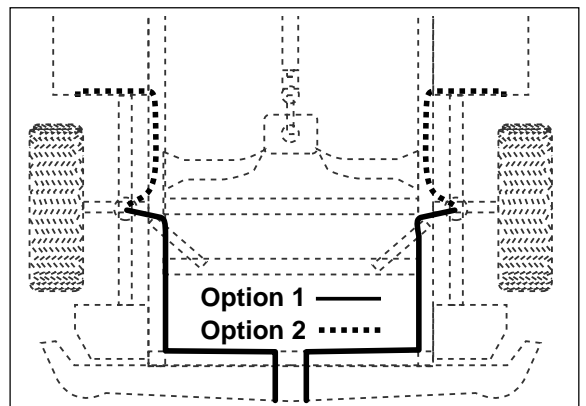

Figure 8

- k. With pliers slide the air line clamp forward until it fully covers the barbed section.
- l. Raise axle or lower body until air cylinders lightly touch upper spring seat and lower spacers.
CAUTION: Do not inflate air cylinders before reading Inflating the Air Springs section.
- m. Continue with Section IV.

IV. TESTING THE AIR SPRINGS

- 1. Inflate the cylinders to 25 lbs of air pressure. Test for air leaks by applying a liquid solution of 1/5 dish soap to 4/5 water to all valve cores, fittings, and connections.
- 2. Lower the vehicle to the ground and deflate the air springs in 5 p.s.i. intervals to determine best ride and handling.
- 3. Recheck air pressure after 24 hours. A 2–4 p.s.i. loss after initial installation is normal. If pressure has dropped by more than 5 lbs, then retest for leaks with the soapy water solution.

V. INFLATING THE AIR SPRINGS

- 1. Inflate the air springs to 20 p.s.i. before adding the payload.
- 2. After vehicle is loaded, adjust the air pressure down to level the vehicle for ride comfort.

VI. MAINTENANCE

- 1. Check air pressure weekly.
- 2. Always maintain at least a 5 p.s.i. air pressure chafing or coil pinch.
- 3. If a leak develops in the system, use a soapy water solution to check all air line connections and valve cores before removing the cylinder.

Minimum Air Pressure	Maximum Air Pressure
5 p.s.i.	25 p.s.i.

Failure to maintain minimum pressure will void the warranty.

	Thank you for purchasing Air Lift Products	
	Mailing Address: AIR LIFT COMPANY P.O. Box 80167 Lansing, MI 48908-0167	Street Address: AIR LIFT COMPANY 2710 Snow Rd. Lansing, MI 48917
Local Phone: (517) 322-2144 Fax: (517) 322-0240		
For Technical Assistance call 1-800-248-0892		

“The Choice of the Professional Installer” Printed in the USA