

For Multiple Applications – See special notes for your particular vehicle.

Please read these instructions completely before proceeding with the installation.

## Escort, Lynx

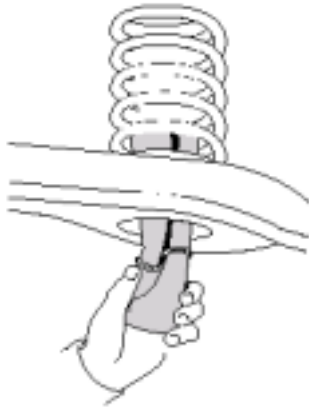

Figure 1

## Escort, Lynx

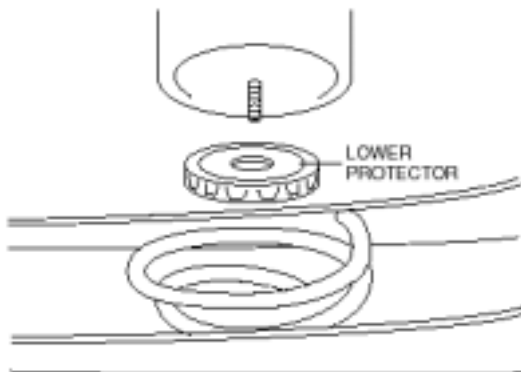

Figure 2

## Tracker, Sidekick, X90, Grand Vitara, Vitara, XL-7

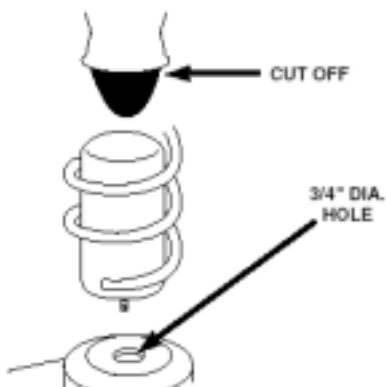

Figure 3

## Escort and Lynx Installation

1. Jack up rear of vehicle or raise on hoist. Support frame with safety stands. Lower axle or raise body of vehicle until suspension is fully extended.
2. Remove plastic cap from barbed stem on end of cylinder. Exhaust the air from the cylinder by rolling it up toward barbed stem. Replace cap on stem to hold flat shape. Form cylinder into a "hot dog bun" shape. If necessary, use a string, tape, or wire to retain shape (Figure 1).
3. Insert formed air cylinder into lower coil spring seat opening with stem at the bottom (Figure 1).
4. Push the cylinder up within the coil by hand or with a blunt instrument such as a spoon-type tire iron.
5. When the cylinder is completely within the coil, remove the cap and allow the cylinder to assume its "as molded" shape (remove ties or tape if used).
6. Push cylinder to the top of the coil and insert protector on top of lower spring seat. Snap downward into position (Figure 2).
7. Continue with air line installation on pages 2 and 3.

## Tracker, Sidekick, X90, Grand Vitara, Vitara, and XL-7 Installation

1. Remove lower shock absorber attaching bolts. Lower axle and remove coil springs noting location of the end of the coil spring in the lower spring seat.
2. Center punch and drill a 3/4" diameter hole in the lower spring seat. Remove all burrs and sharp edges (Figure 3).

*NOTE: Due to the offset spring seat, it may be helpful to set the spring, with the bag installed, on vehicle to see where stem will contact lower spring seat. This is where the hole should be drilled.*

3. Cut off exposed portion of rubber jounce bumper within 1/2" of metal cup (Figure 3).
4. Insert air cylinder into coil spring with stem at bottom. Push the cylinder inside the coil by hand or with a blunt instrument such as a spoon-type tire iron.
5. Re-install coil spring into spring seats and rotate to proper location. Re-attach lower shock absorber. Torque to 25 ft. lbs.
6. Continue with air line installation on page 2 and 3.

*Tee air line installation recommended unless weight in vehicle varies from one side to the other and unequal pressures are needed to level the load. Dual air lines are used in this case.*

## Tee Air Line Routing

**TO PREVENT AIR LINE FROM MELTING, KEEP IT AT LEAST EIGHT INCHES FROM EXHAUST SYSTEM.**

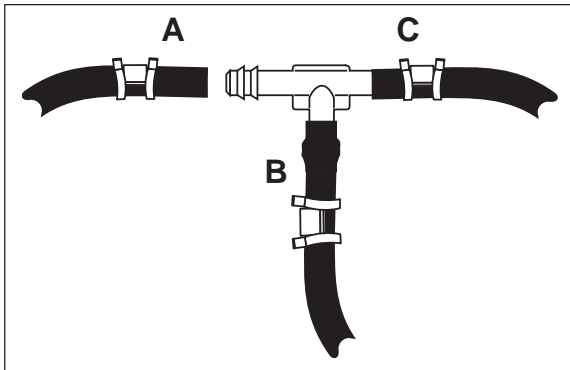

Use this procedure for all air line connections:

- A. Slide air line clamp onto the air line.
- B. Push the air line over the barbed stem.
- C. Compress ears on air line clamp with pliers and slide it forward to fully cover barbed section.

Figure 4

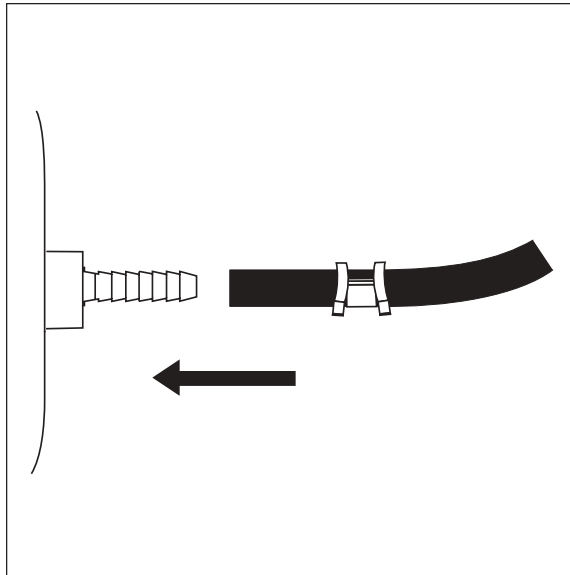

Figure 5

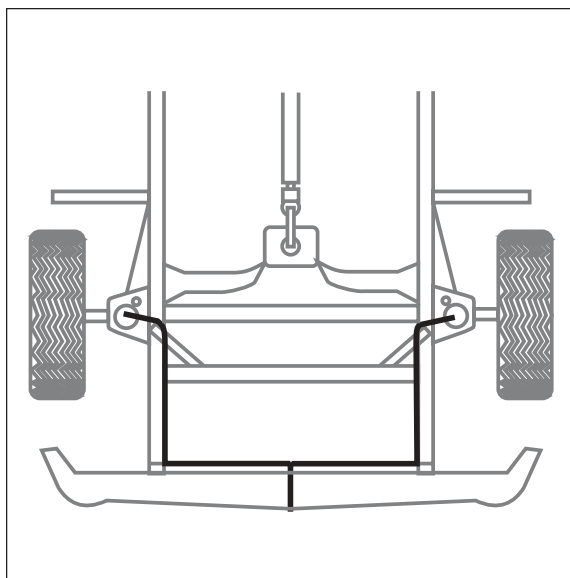

Figure 6

- A. Locate desired tee location on the frame rail or cross member.
  - B. Determine and cut adequate length of air line to reach from tee to left and right side on air cylinders.
 

*CAUTION: LEAVE SUFFICIENT AIR LINE SLACK TO PREVENT ANY STRAIN ON FITTING DURING AXLE MOTIONS.*
  - C. Slide air line clamp onto the air line.
  - D. Push the air line over one side of the tee until all the barbs are covered. Repeat procedure for other leg of tee (Figure 4).
  - E. With pliers slide the air line clamp forward until it fully covers the barbed section. Repeat for other leg of tee (Figure 4).
  - F. Route along cross member and either lower control arm or upper spring seat to air cylinder.
  - G. Insert air line through spring seat.
  - H. Push the air line onto the stem, covering all the barbs (Figure 5).
  - I. With pliers slide the air line clamp upward until it fully covers the barbed section.
  - J. Push the remaining air line over the last fitting on tee and route along frame to desired inflation valve location (Figure 6). Attach with plastic straps or wire.
  - K. Select a location for inflation valve in the gas cap well, the truck, rear bumper, fender flange or behind the license plate, insuring that the valve will be protected and accessible with an air hose.
  - L. Drill a 5/16" hole for inflation valve and mount as in illustration (Figure 8). Rubber washer is for outside weather seal.
  - M. Slide air line clamp over the air line. Push air line onto fitting covering all barbs, with pliers slide the air line clamp forward until it fully covers the barbed section (Figure 7).
  - N. Raise axle or lower body until air cylinders lightly touch upper spring seat and lower spacers.
  - O. Check TAILPIPE clearance and insure that it is at least 2-3 inches from air cylinder. If necessary, loosen clamps and rotate or move to obtain additional clearance. If heat shield is provided, install it. Attach shock absorbers if removed earlier in the installation.
- DO NOT INFLATE AIR CYLINDERS BEFORE READING INFLATION PROCEDURES.**
- P. Continue with step 7, page 4.

## Dual Air Line Routing

### TO PREVENT AIR LINE FROM MELTING, KEEP IT AT LEAST EIGHT INCHES FROM EXHAUST SYSTEM.

A. Select a location for the inflation valves in the rocker panel flange, or rear bumper, insuring that each valve will be protected and accessible with an air hose (Figure 9).

B. Determine and cut adequate length of air line to reach from valve location to left side air cylinder.

**CAUTION: LEAVE SUFFICIENT AIR LINE SLACK TO PREVENT ANY STRAIN ON VALVE STEM DURING NORMAL AXLE MOTIONS.**

C. Insert the air line through the spring seat and spacer.

D. Slide air line clamp onto the cut air line.

E. Push the air line onto the stem, covering all the barbed section (Figure 5).

F. With pliers slide the air line clamp forward until it fully covers barbed section (Figure 5).

G. Repeat process for right side.

H. Drill 5/16" hole for inflating valves and mount as illustrated. Rubber washer is for outside weather seal (Figure 8).

I. Route air line along control arm and frame to inflation valve location and cut off excess.

J. Slide a clamp onto the air line and push the air line over the fitting, covering all the barbs.

K. With pliers slide the air line clamp forward until it fully covers the barbed section.

L. Raise axle or lower body until air cylinders lightly touch upper spring seat and lower spacers.

M. Check TAILPIPE clearance and insure that it is at least 2-3 inches from air cylinders, If necessary, loosen clamps and rotate or move to obtain additional clearance. If heat shields are supplied, install them.

N. Attach shock absorbers if removed earlier in the installation.

**DO NOT INFLATE AIR CYLINDERS BEFORE READING INFLATION PROCEDURES.**

N. Continue with step 7, page 4.

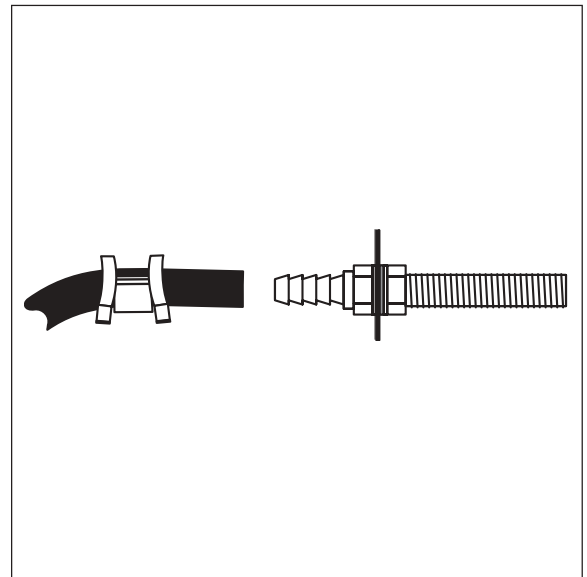

Figure 6

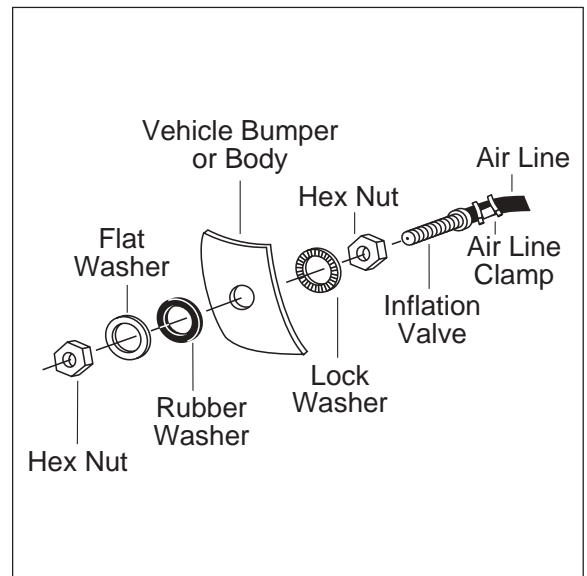

Figure 7

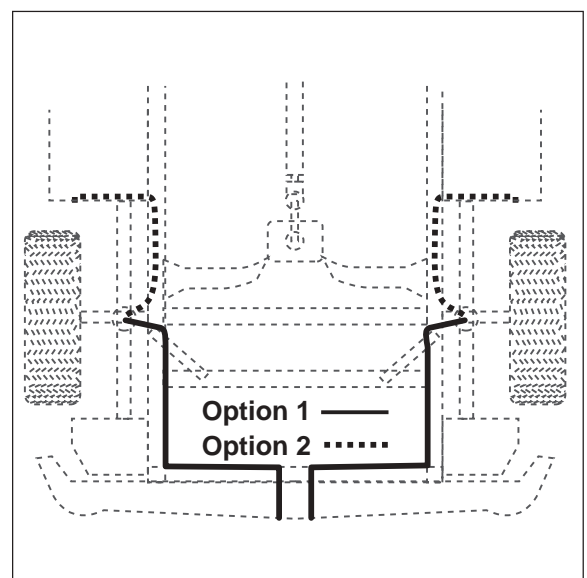

Figure 8

7. Inflate cylinders to 30 lbs. air pressure. Test for air leaks by applying a liquid soap and water solution to all valve cores, fittings and connections.
8. Lower vehicle to the ground. Deflate the air springs in 5 p.s.i. intervals to determine the best ride and handling. Read Maintenance/Operation Tips for proper care of your air cylinders. Recheck air pressure after 24 hours. A 2 - 4 p.s.i. loss after initial installation is normal. If pressure has dropped more than 5 lbs. re-test for leaks with soapy water solution.

### Inflation Procedure:

1. Inflate your air springs to 35 p.s.i. before adding the payload. After vehicle is loaded, adjust your air pressure (down) to level the vehicle and for ride comfort.

### Maintenance and Operations:

MINIMUM AIR PRESSURE	MAXIMUM AIR PRESSURE
5 psi	25 psi

By following these steps, vehicle owners should obtain the longest life and best results from their air springs.

#### Maintenance Tips:

1. Check the air pressure in the air springs weekly.
2. Always maintain at least the 5 p.s.i. air pressure to prevent chafing or coil pinch.
3. If a leak develops in the system, use a solution of 1/5 dish soap to 4/5 water to check all air line connections and the valve core before removing the cylinder.

#### Operating Tips:

1. Inflate your air springs to 25 p.s.i. before adding the payload. This will allow the air cylinder to properly mesh with the coil spring. After vehicle is loaded, adjust air pressure (down) to level the vehicle and for ride comfort.
2. When carrying a payload, it will be helpful to increase the tire inflation pressure in proportion to any overload condition. We recommend a 2 p.s.i. increase above normal (not to exceed tire manufacturers maximum) for each 100 lbs additional load on the axle.

**CAUTION:** Do not exceed the vehicle manufacturers maximum gross vehicle weight rating.

**CAUTION:** Failure to maintain minimum pressure will void the warranty.



#### **Thank you for purchasing Air Lift Products**

Mailing Address:  
 AIR LIFT COMPANY  
 P.O. Box 80167  
 Lansing, MI 48908-0167

Street Address:  
 AIR LIFT COMPANY  
 2727 Snow Rd.  
 Lansing, MI 48917

Local Phone: (517) 322-2144  
 Fax: (517) 322-0240

**For Technical Assistance call 1-800-248-0892**

*“The Choice of the Professional Installer”*