

Multiple Applications – See special notes for your particular vehicle.

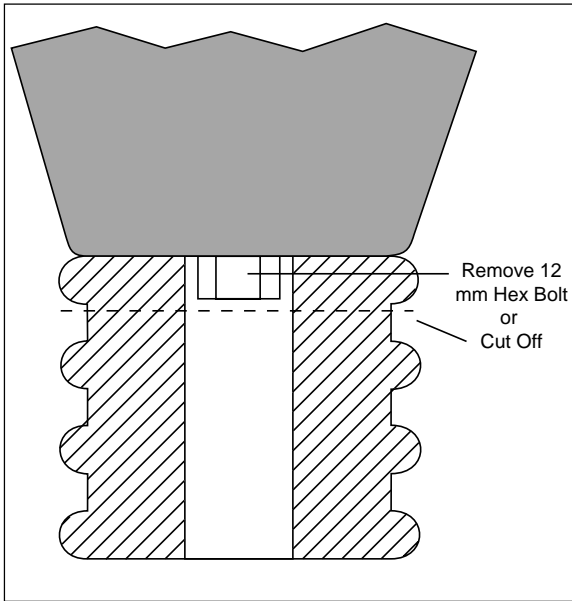

Figure 1

I. Preparing the Vehicle

NOTE For Toyota Sequoias: Before proceeding with the installation, measure up 6.75" from the flat surface that the jounce bumper strikes inside the coil spring and mark a line onto the side of the jounce bumper. This is where the jounce bumper will be trimmed.

1. Jack up rear of vehicle or raise on hoist. Support frame with safety stands. Lower axle or raise body of vehicle until suspension is fully extended.
2. The coil springs must be removed for this installation:
 - a. Detach the shock absorbers at the lower shock mount.
 - b. Detach the panhard bar at the lower bar mount.
 - c. Temporarily disconnect the brake line mounting brackets on the rear axle. This will keep the tension off of the brake lines when the axle is dropped to remove the coil springs.
 - d. Carefully lower the axle until the coil springs are free. Do not strain brake lines. Mark the position of the cut end of the coil spring on the upper spring seat so that the coil springs can be reinstalled in the same position. Remove coil springs.
3. Cut off the exposed portion of the rubber jounce bumper (Figure 1).

NOTE: Sequoias cut on the previously marked line.

4. Cut out the template provided (Line B). Put a dab of grease on the template to hold it in place. Center the template in the cup of the upper side of the lower spring seat. Center punch and drill a 3/4" diameter hole. Remove any burrs and sharp edges.
5. User may select either Dual Air Line or Tee Air Line option depending on the use of the vehicle. Tee Air line installation is recommended unless weight on the vehicle varies from one side to the other, in which case Dual Air Line installation is recommended to level the vehicle side to side (See Air Line Installation instructions to prep air springs before continuing).
6. Insert the air cylinders into the coil springs with air lines hanging down.
7. Thread the air line through the drilled hole in the lower spring seat, routing the line to the side of the axle (front or rear) on which the inflation valves will be mounted.
8. Reinstall the coil springs in the vehicle. Be sure to line up the cut end of the upper coil spring with your mark on the upper spring seat. Carefully raise the axle to seat the springs.
9. Reattach all components disconnected under step 2:
 - a. Reconnect the brake lines to mounting brackets on the rear axle.
 - b. Reconnect the panhard bar.
 - c. Reconnect the shock absorbers.

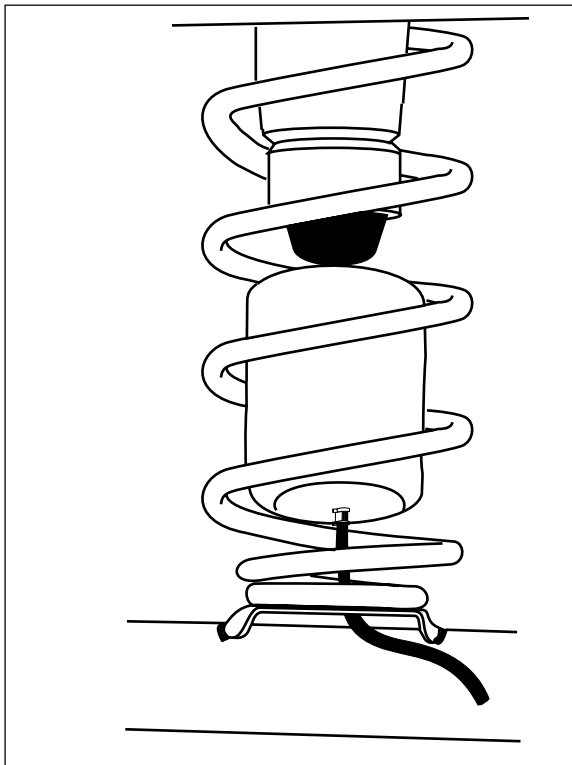

Figure 2

10. Continue with air line installation instruction.

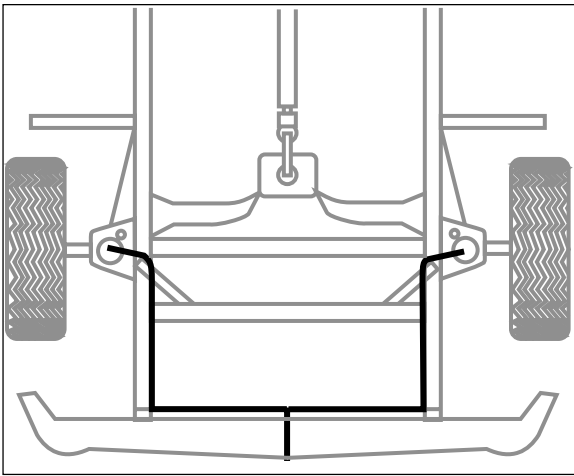

Figure 3 - TEE AIR LINE

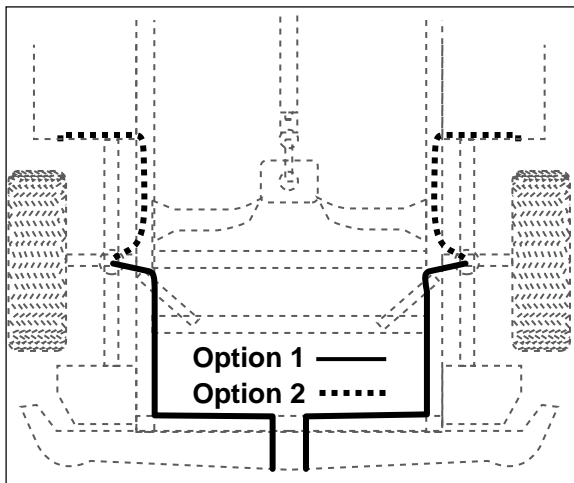

Figure 4 - DUAL AIR LINE

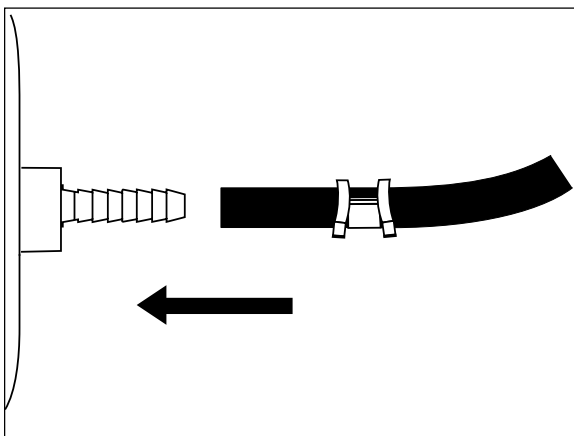

Figure 5

II. Air Line Instructions

CAUTION: LEAVE SUFFICIENT AIR LINE SLACK TO PREVENT ANY STRAIN ON FITTINGS DURING AXLE MOTIONS.

TO PREVENT AIR LINE FROM MELTING, KEEP IT AT LEAST TWELVE INCHES FROM EXHAUST SYSTEM, ENGINE AND HEAT SOURCES. CAUTION: AVOID AREAS WHICH MAY CAUSE FAILURE OF THE AIR LINE. FOR EXAMPLE: BATTERY, EXHAUST, ENGINE, AND MOVING PARTS SUCH AS STEERING, SUSPENSION AND CABLES.

TEE AIR LINE CONNECTION:

- A. Find desired tee location on the frame rail or radiator core support bracket (Figure 3).
- B. Determine and cut adequate length of air line to reach from tee to left and right side on air cylinders.
- C. Connect the air line to the two opposite legs on the tee (Figure 5).
- D. Route air line to left and right air springs, generally along inner fender panel or frame rails.
- E. Slide air line clamp onto the air line. Push the air line over the barbed end of straight fitting. Compress the ears on the air line clamp with pliers and slide it down to cover the barbed section (Figure 5). Repeat for other side.
- F. Connect the straight fitting to the right & left air springs and tighten securely.
- G. Select a location for inflation valve in the hood release, front bumper, fender flange or behind the license plate, ensuring that the valve will be protected and accessible with an air hose.
- H. Connect the remaining air line over the last fitting on tee and route along frame to desired inflation valve location. Attach air line to chassis with provided plastic straps.
- I. Drill a 5/16" hole for inflation valve and mount as illustrated (Rubber washer is for outside weather seal (Figure 6).
- J. Connect the air line to the inflation valve (Figure 6).
- K. Continue with step 11

DUAL AIR LINE CONNECTION:

- A. Select a location for the inflation valves in the rocker panel flange or by hood release insuring that each valve will be protected and accessible with an hose.
- B. Determine and cut adequate length, not longer than 90" of air line to reach from valve location to left side air cylinder.
- C. Slide air line clamp onto the air line. Push the air line over the barbed end of straight fitting. Compress the ears on the air line clamp with pliers and slide it down to cover the barbed section (Figure 5). Repeat for other side.
- D. Connect the straight fitting to the right & left air springs and tighten securely.
- E. Route air line along frame or under fender panel to desired inflation valve location (Figure 4). Attach air line to chassis with plastic straps or wire.
- F. Drill 5/16" hole for inflating valves and mount as illustrated (Rubber washer is for outside weather seal, Figure 7).
- G. Connect the air line to the inflation valve (Figure 8).
- H. Repeat process for right side.
- I. Continue with step 11

11. Inflate Air Springs to 35 p.s.i. Check for air leaks at all fittings and valve core with a soapy water solution.
12. Replace wheels, remove safety stands and carefully lower vehicle to ground.
13. Deflate Air Springs in 5 p.s.i. intervals to determine best ride and handing. Sufficient air pressure should be maintained to help prevent bottoming-out on large bumps, chuck holes, ect
14. Recheck air pressure after 24 hours. A 2-4 p.s.i. loss is normal after initial installation. If the pressure has dropped more than 5 p.s.i. re-test for leaks with a soapy water solution. Please read and follow the Maintenance and Operation Tips on page 4.

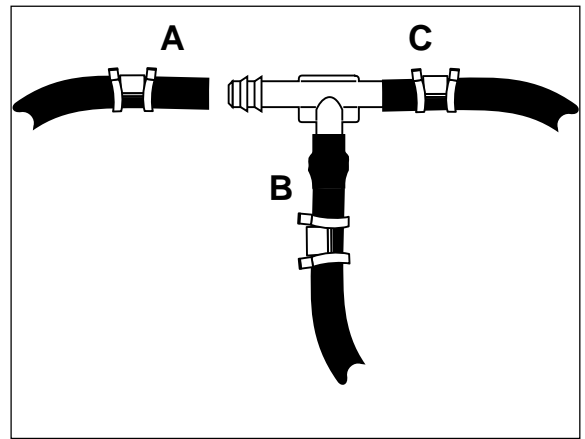

Use this procedure for all air line connections:

- A. Slide air line clamp onto the air line**
- B. Push the air line over the barbed stem.**
- C. Compress the ears on the air line clamp with pliers and slide it forward to fully cover the barbed section.**

Figure 6

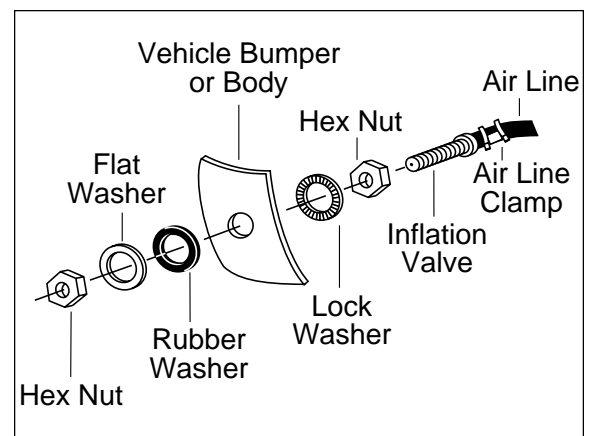

Figure 7

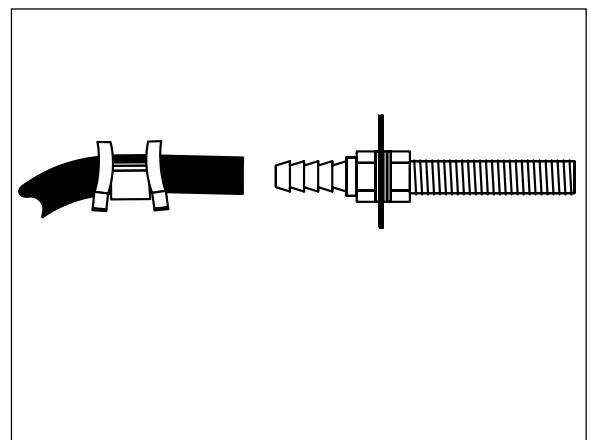

Figure 8

MINIMUM AIR PRESSURE	MAXIMUM AIR PRESSURE
5 psi	35 psi

Maintenance and Operations

By following these steps, vehicle owners should obtain the longest life and best results from their air springs.

Maintenance Tips:

1. Check the air pressure in the air springs weekly.
2. Always maintain at least the 5 p.s.i. air pressure to prevent chafing or coil pinch.
3. If you develop a leak in the system, use a soapy/water solution to check all air line connections and the valve core before removing the cylinder.

Operating Tips:

1. Inflate your air springs to 35 p.s.i. before adding the payload. This will allow the air cylinder to properly mesh with the coil spring. After vehicle is loaded, adjust your air pressure (down) to level the vehicle and for ride comfort.
2. When you are carrying a payload it will be helpful to increase the tire inflation pressure in proportion to any overload condition. We recommend a 2 p.s.i. increase above normal (not to exceed tire manufacturers maximum) for each 100 lbs. additional load on the axle.

CAUTION: *Do not exceed the vehicle manufacturers maximum gross vehicle weight rating.*

CAUTION: *Failure to maintain minimum pressure will void the warranty.*

Thank you for purchasing Air Lift Products



Mailing Address:
 AIR LIFT COMPANY
 P.O. Box 80167
 Lansing, MI 48908-0167

Street Address:
 AIR LIFT COMPANY
 2727 Snow Rd.
 Lansing, MI 48917

Local Phone: (517) 322-2144
 Fax: (517) 322-0240

For Technical Assistance call 1-800-248-0892

“The Choice of the Professional Installer”

Printed in the USA