



Installation Instructions Part Number 883-300

2011-12 Polaris Ranger RZR XP
2012 Polaris Ranger RZR XP 4
900 E.F.I.



Thank you for purchasing the Airaid Intake System. Contact Airaid @ (800) 498-6951 8:00 AM - 5:00 PM MST weekdays for questions regarding fit or instructions that are not clear to you. Your Airaid Intake System was carefully inspected and packaged. Check that no parts are missing, or were damaged during shipping. If any parts are missing, contact Airaid. The air filter element is protected from direct exposure to water and debris; care should be taken not to drive through deep water. WATER INGESTION IS THE DRIVERS RESPONSIBILITY

Tools Required For Installation:
7/16" and 1/2" Wrenches. 10mm, 7/16", and 1/2" Sockets.
T-27 Torx driver and 5/32" Allen Wrench. Ratchet & Extension. 1/8" & 5/16" Drill bits.
Center punch and Mallet
Phillips and Standard Tip Screwdrivers.
Loctite® 242 or equivalent, and a Prep-Solvent.

AIR AID® INTAKE SYSTEMS

Advisory Note:

Please read these installation instructions in their entirety before beginning the install process. Airaid strongly recommends the use of Loctite® 242 Medium strength threadlocker on all threaded fasteners.



1. Place the range selector in Park and remove the drivers seat from the vehicle. Disconnect the negative terminal on the battery.



2. Starting on the Drivers side first, remove the nine T-27 head screws holding the fender in place. Remove the fender and place it on a work bench.



3. Remove the OEM filter cover and pre filter from the fender and set aside. They will not be reused.

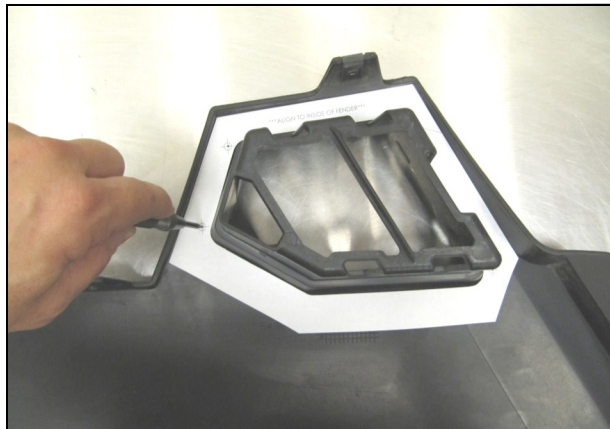

4. Cut out the paper Template. Align it with the edges of inner fender, and punch the four pilot holes. Be careful with the Template as it will be re used on the passenger side fender too.



5. Using a drill and a 1/8" bit, drill out the four pilot holes in the inner fender.



6. Using a 9/32" bit, drill out the pilot holes.



7. Prepare the mating surface of the Fender Adapter (#2) for the Foam Gasket Tape (#10) by cleaning with a prep solvent. Apply the gasket tape along the outside edge of the Fender Adapter as shown, avoiding the bolt holes.

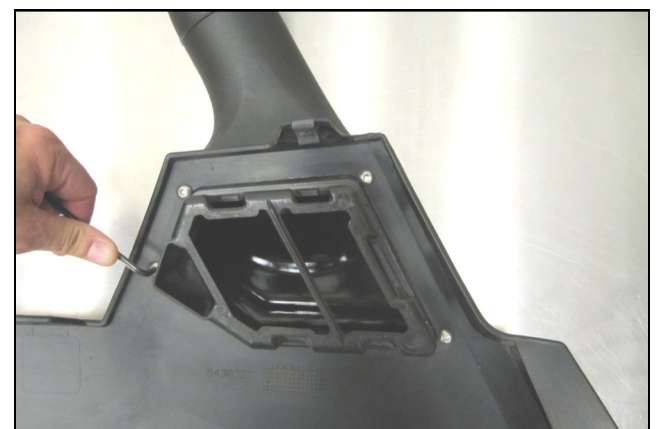

8. Attach the Fender Adapter to the outside of the factory Fender using four 1/4-20 button head screws (#14).



9. Re install the fender onto the vehicle, reusing the nine fasteners from step 2.



10. Insert the Foam Pre Filter (#6) into the Snorkel Inlet (#4).

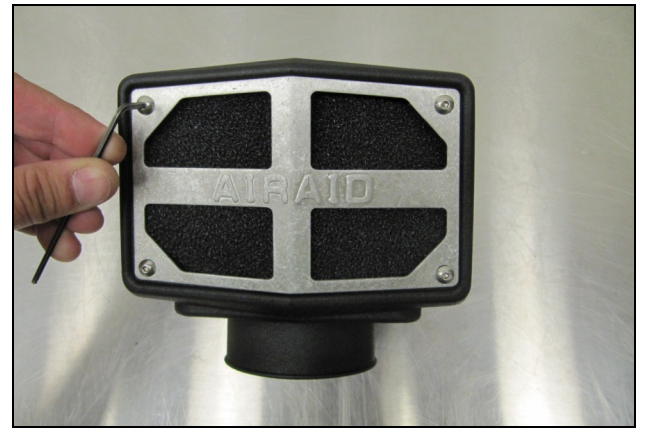

11. Install the Snorkel Screen (#5) onto the Inlet using four 8-32 Button Head Screws (# 13) and a 5/32" Allen wrench.



12. Install the Hump Hose (#8) and Aluminum Intake Tube (#3) onto the Fender adapter. Loosely install two #48 Clamps (#8) onto the Hump Hose.



13. Install the Silicone Elbow (#7) and two #48 clamps onto the Inlet as shown. Leave the Hose Clamps loose for now.

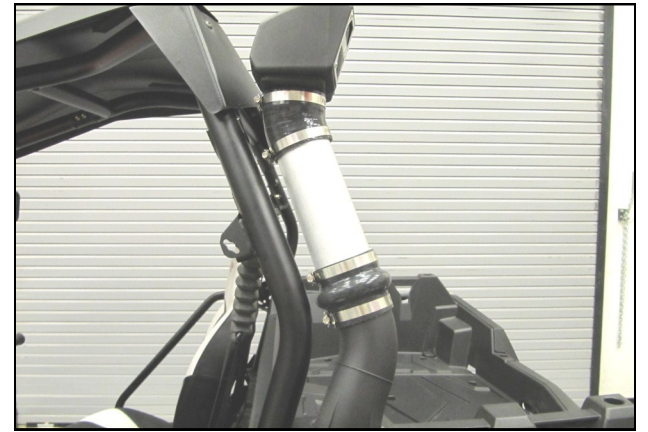

14. Install the Snorkel Inlet and elbow onto the Intake tube. Align the assembly into the desired position and tighten all of the Clamps. Repeat steps 2-14 on the Passenger side and re use the template, face down.

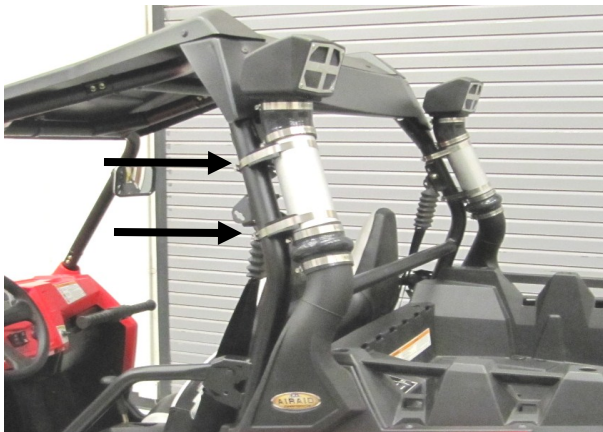

15. Secure the snorkel assemblies to the roll cage using the Tube Mounts (#9) and #68 Clamps (#12). Align the Snorkels to each other for symmetry.

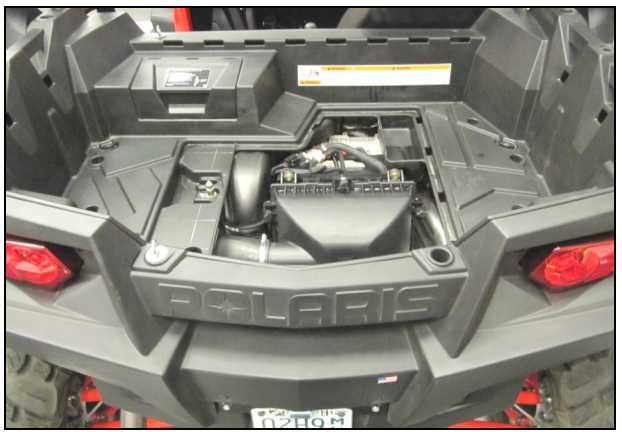

16. Remove the access hatch in the bed and remove the factory air filter from the airbox.

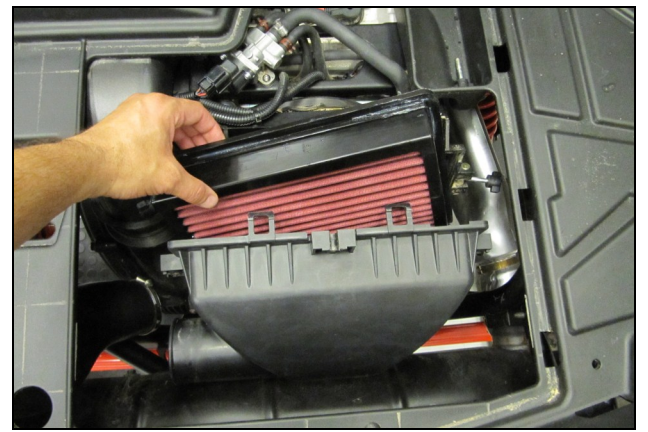

17. Apply the supplied silicone grease (#15) to both sides of the sealing flange on the Airaid Premium Filter. Install the filter as shown, flange first, with the domed portion facing away from the engine.



18. **Double check your work!** Make sure there is no foreign material in the intake path. Make sure all clamps, hoses, bolts, and screws are tight. Make sure all clamps, hoses, bolts, and screws are tight. Periodically check the tightness of all hose clamps.

Re-connect the negative battery cable and re install the driver seat.

Don't Forget Your AIRAID Filter Tune-Up Kit!

P/N 790-551 Aerosol Spray
P/N 790-550 Squeeze Spray

Filter Service

Airaid recommends following the manufacturer's maintenance schedule for filter cleanings.

“Air filters should be inspected before each ride. Filter and pre-filter need to be replaced at least annually and more often if subjected to severe use.”

The Airaid Filter is reusable and should be cleaned using the Airaid Filter Tune-Up Kit.



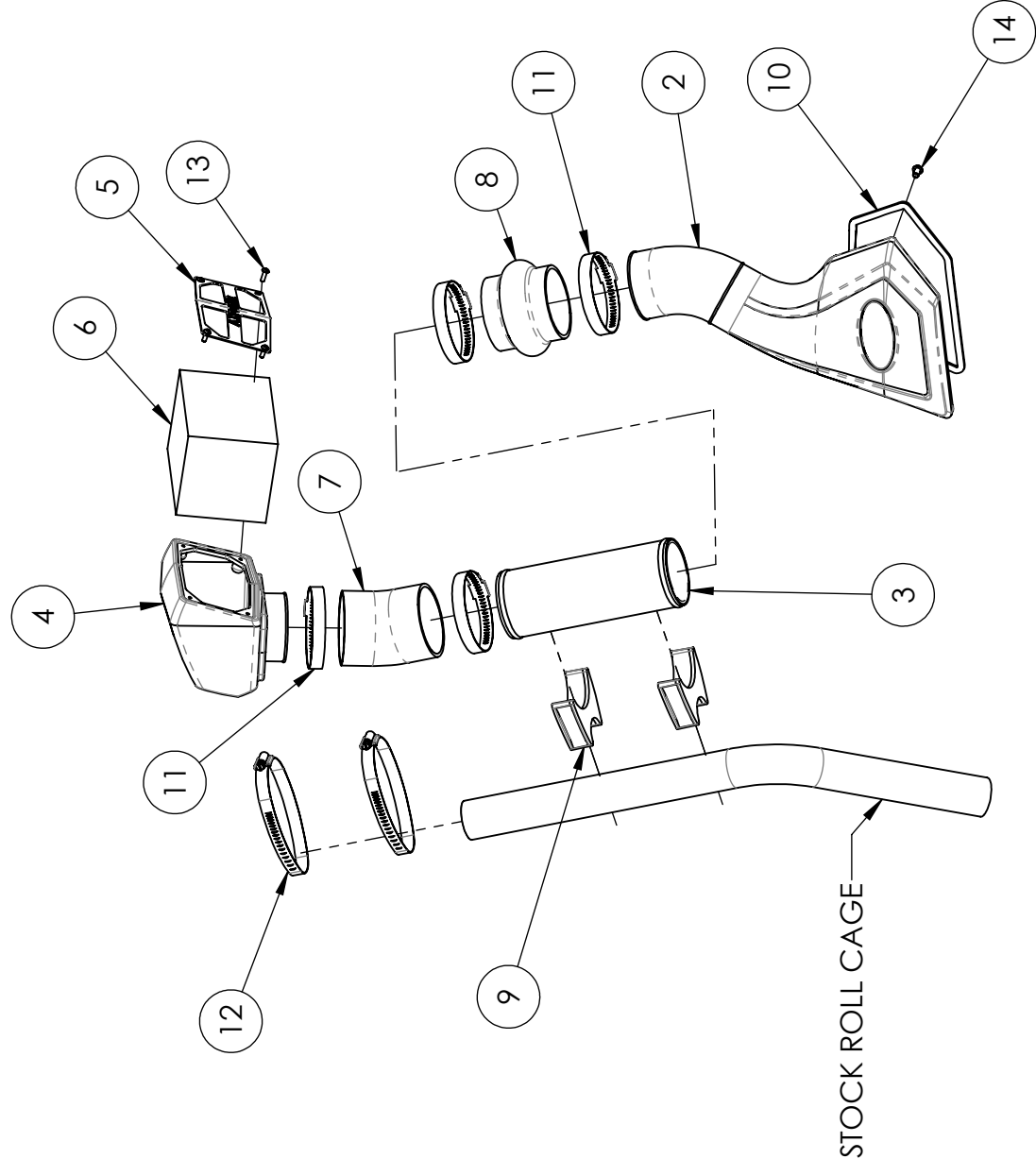

DRIVER SIDE ASSEMBLY SHOWN

ITEM NO.	AiraidPackinglistDESCR	AiraidPackinglistP/N	QTY.
1	AIRAID Premium Filter (NOT SHOWN)	850-352	1
2	Fender Adapter, Left & Right	KIT300LSFA/KIT300RSFA	2
3	3.00" X 8.00" Aluminum Tube	KIT300ALT	2
4	Snorkel Inlet	KIT300SIT	2
5	Snorkel Screen	KIT262SS	2
6	Foam Prefilter	KIT262PF	2
7	3.00" 25° Silicone Elbow	KITELBOW10	2
8	Silicone Hump Hose	KITHUMPHS06S	2
9	Urethane Tube Mount	KIT300UTM	4
10	Foam Gasket Tape, 24"	KITWSTRIP05	2
11	#48 Hose Clamp	KITHS48	8
12	#68 Hose Clamp	KITHS68	4
13	#8-32 x 1/2" Button Head Screw	KIT15BHC3050	8
14	1/4-20 x 1/2" Button Head Screw	KIT15DHC3050	8

MARK WITH CENTERPUNCH, DRILL 1/8" PILOT HOLE
THEN DRILL USING 9/32" BIT, ADJUST AS NECESSARY

