

# ridetech

Air Ride Technologies



350 S. St. Charles St. Jasper, In. 47546

Ph. 812.482.2932 Fax 812.634.6632

[www.ridetech.com](http://www.ridetech.com)

## Part #11012401

### 55-57 Chevy Car Front Master Series SA ShockWaves

For Use w/ Stock Lower Arms

#### ShockWave Assembly:

2	21190399	104mm Master Series rolling sleeve assembly
2	21129999	2.6" stroke Master Series single adjustable shock
2	90001632	Internal bump stop
2	90001686	.625" I.D. bearing
2	90001900	Bearing snap ring
2	90002010	Extended width T-bar
4	90001980	T-bar snap ring
2	90001906	Short Delrin stud top – 2"

#### Components:

2	90001834	Short Delrin stud top base – 2"
2	90001902	Aluminum cap for Delrin ball
2	90001903	Delrin ball upper half
2	90001904	Delrin ball lower half
2	31954201	1/4"npt x 1/4" tube swivel elbows

#### Hardware:

4	99562002	9/16" SAE jam nut	Stud top hardware
4	99371004	3/8" x 1 1/4" USS bolt	T-Bar to lower arm
4	99372002	3/8" USS Nylok nut	T-Bar to lower arm
8	99373002	3/8" SAE flat washer	T-Bar to lower arm

## Installation Instructions

1. Raise and support vehicle at a safe, comfortable working height. Let the front suspension hang freely.
2. Remove the coil spring and shock absorber. Refer to a factory service manual for proper disassembly procedure.

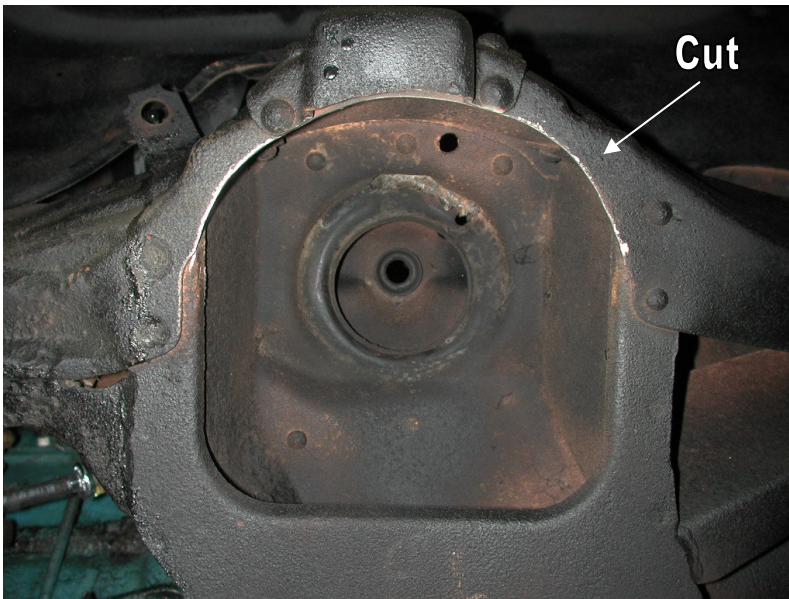

3. For air spring clearance some trimming must be done on the outer lip of the coil spring pocket. This is what it should look like after cutting.

4. This is best done with a cut off wheel or plasma cutter. Grind all cuts smooth when finished.

**Allowing the shockwave will rub will result in failure, this is not a warrantable situation.**

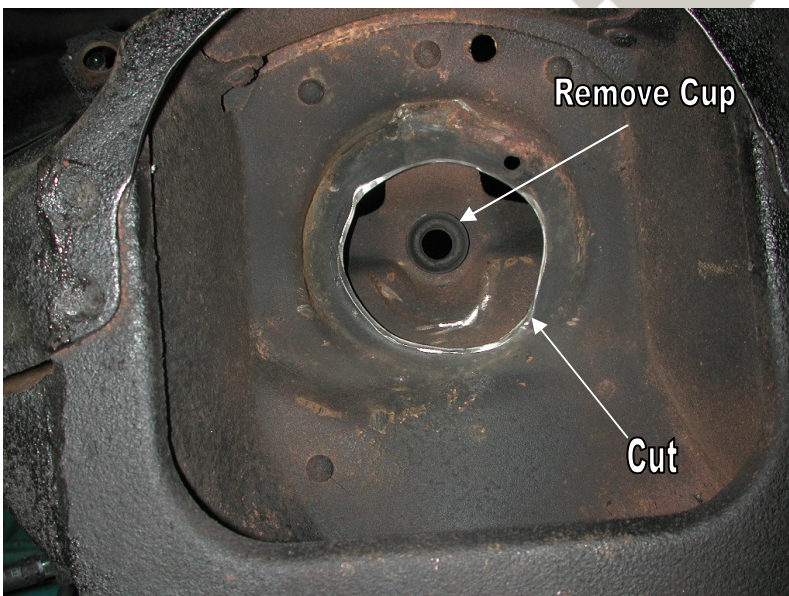

5. The domed portion of the Shockwave will hit the coil spring retainer. This lip must be removed.

6. The factory upper bushing cup must also be removed.

7. Apply thread sealant to a 90 degree air fitting and screw it into the top of the Shockwaves. The fitting location can be rotated by twisting the bellow while holding the shock body.

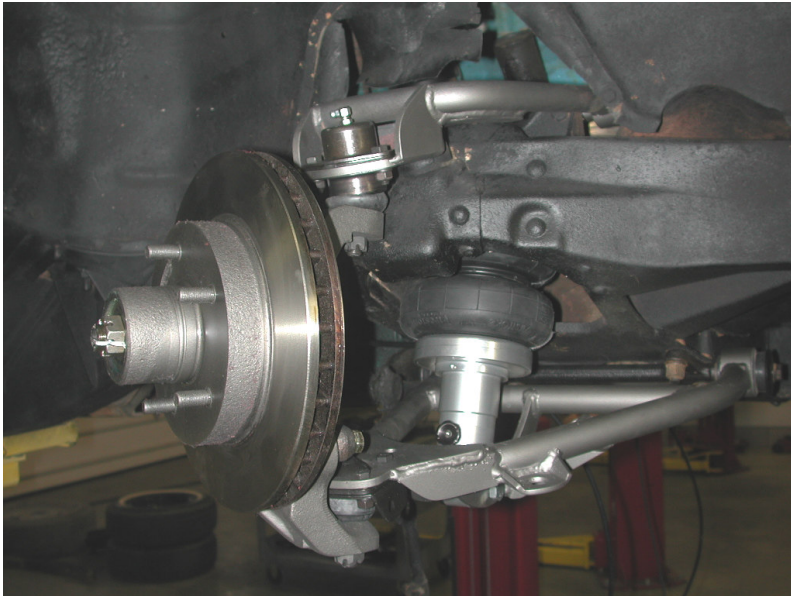

8. Place the Shockwave up into the coil spring pocket with the stud protruding through the factory shock hole. See diagram below. The factory shock hole may need to be drilled out to  $\frac{3}{4}$ ".

9. Fasten the Shockwave to the factory lower control arm using two  $\frac{3}{8}$ " x  $1\frac{1}{4}$ " bolt, flat washers and nylok nuts. The T-bar will sit on **top** of the lower arm. (This picture shows the StrongArms)

10. Ride height will be around 90-100 psi, but will vary to driver preference.

1. 90001834- Short Delrin stud top base – 2"
2. 90001904- Delrin ball lower half
3. 90001903- Delrin ball upper half
4. 90001902- Aluminum cap for Delrin ball
5. 99562002- 9/16" SAE jam nut
6. 90001906- Short Delrin stud top – 2"
7. Black adjustment knob
8. Detent clip
9. Screw
10. Washer

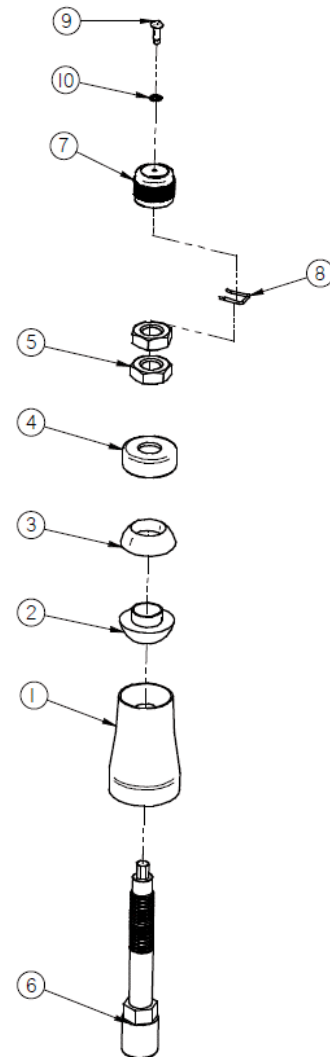

# Shock Adjustment Instructions



## Compression Adjuster

The compression adjustment is made on the body end of the shock.

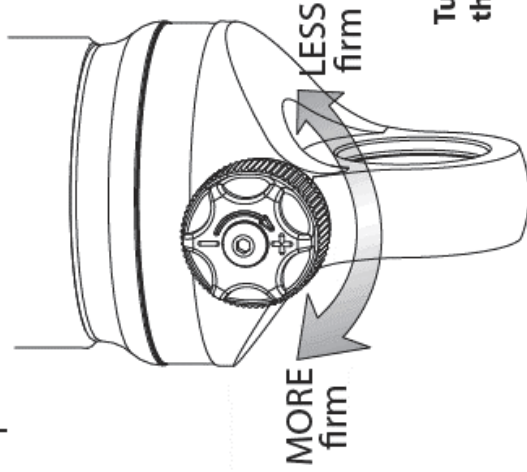

Turning the knobs clockwise tightens the valving, making the shock stiffer.

## Rebound Adjuster

The rebound adjustment is made on the shaft end of the shock.

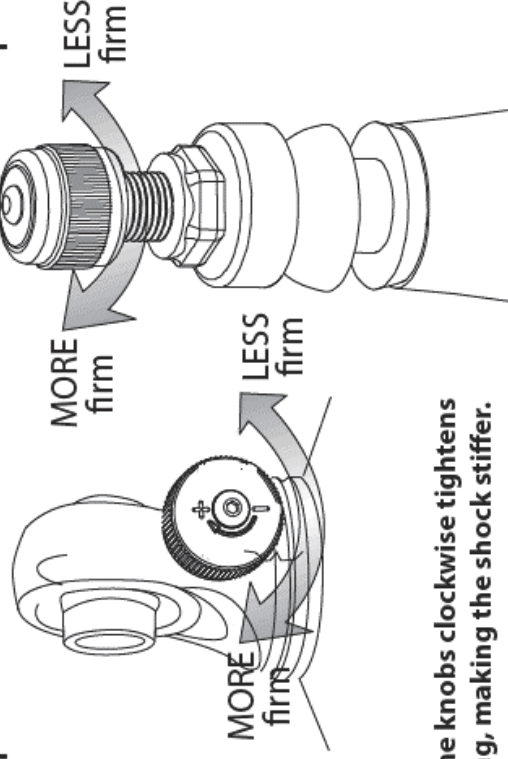

The rebound and compression knobs work completely independently from one another.

Because of the fine adjustment range RideTech recommends adjusting 3-4 clicks minimum when making a shock valve change.

**All RideTech Shocks are shipped from the factory at the FULL SOFT position.**

**Please note: Only rotate adjustment knob while feeling the "click"**  
Trying to rotate knob past the last click could result in damage to the adjuster internal mechanism.

**ridetech.com • 812-482-2932**



## The care and feeding of your new ShockWaves

1. Although the ShockWave has an internal bumpstop, **DO NOT DRIVE THE VEHICLE DEFLATED RESTING ON THIS BUMPSTOP. DAMAGE WILL RESULT.** The internal bumpstop will be damaged, the shock bushings will be damaged, and the vehicle shock mounting points may be damaged to the point of failure. **This is a non warrantable situation.**
2. Do not drive the vehicle overinflated or “topped out”. Over a period of time the shock valving will be damaged, possibly to the point of failure. **This is a non warrantable situation!** If you need to raise your vehicle higher than the ShockWave allows, you will need a longer unit.
3. The ShockWave is designed to give a great ride quality and to raise and lower the vehicle. **IT IS NOT MADE TO HOP OR JUMP!** If you want to hop or jump, hydraulics are a better choice. This abuse will result in bent piston rods, broken shock mounts, and destroyed bushings. **This is a non warrantable situation.**
4. Do not let the ShockWave bellows rub on anything. Failure will result. **This is a non warrantable situation.**
5. The ShockWave product has been field tested on numerous vehicles as well as subjected to many different stress tests to ensure that there are no leakage or durability problems. Failures have been nearly nonexistent unless abused as described above. If the Shockwave units are installed properly and are not abused, they will last many, many years. **ShockWave units that are returned with broken mounts, bent piston rods, destroyed bumpstops or bushings, or abrasions on the bellows will not be warrantied.**