

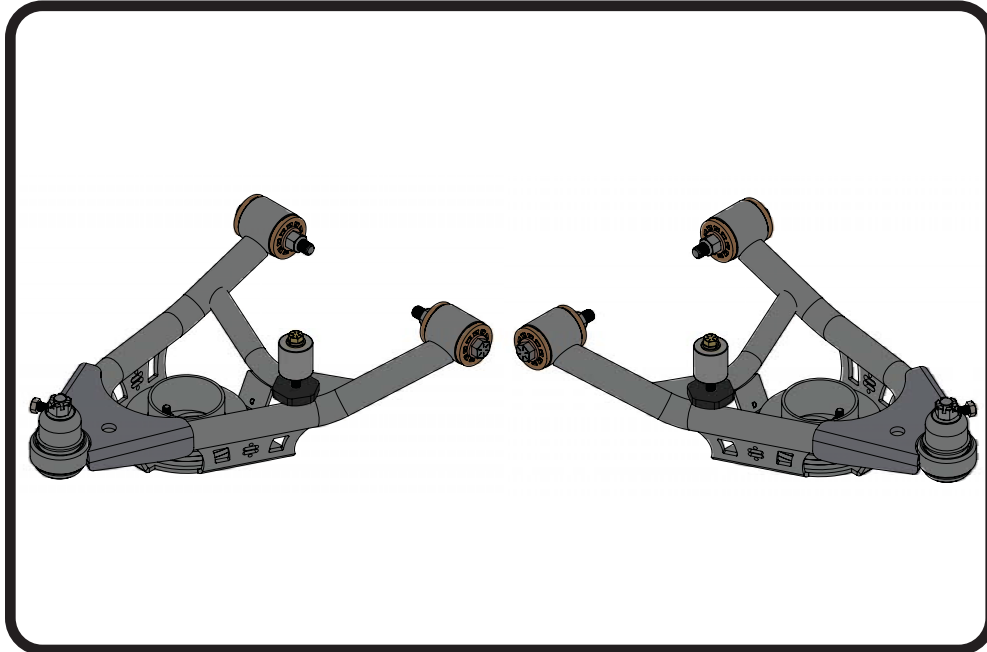

**Part # 11162199 - 1967-1969 GM F-Body Front Coil Spring StrongArms**



### Recommended Tools



## 1967-1969 GM F-Body Coil Spring StrongArms Installation Instructions

### Table of contents

Page 2.....	Lower Control Arm Components
Page 3.....	Getting Started & Ride Height Adjustment
Page 4-8.....	Installation
Page 8.....	Alignment





### Lower Control Arm Components .....In the box

Item #	Part Number	Description	QTY
1	90003330	Driver Lower Control Arm ( <b>Shown</b> )	1
1	90003331	Passenger Lower Control Arm	1
2	90000898	Lower Ball Joint Assembly	2
3	70010759	Delrin Bushing - with 2" Diameter Ledge	8
4	90000516	1/2" ID Inner Sleeve	4
5	90003349	1/4" Coil Spring Spacer	6
6	90000247	Coil Spring Isolator	2
7	90003360	Bump Stop Spacer	2
8	70013322	Medium Bump Stop	2

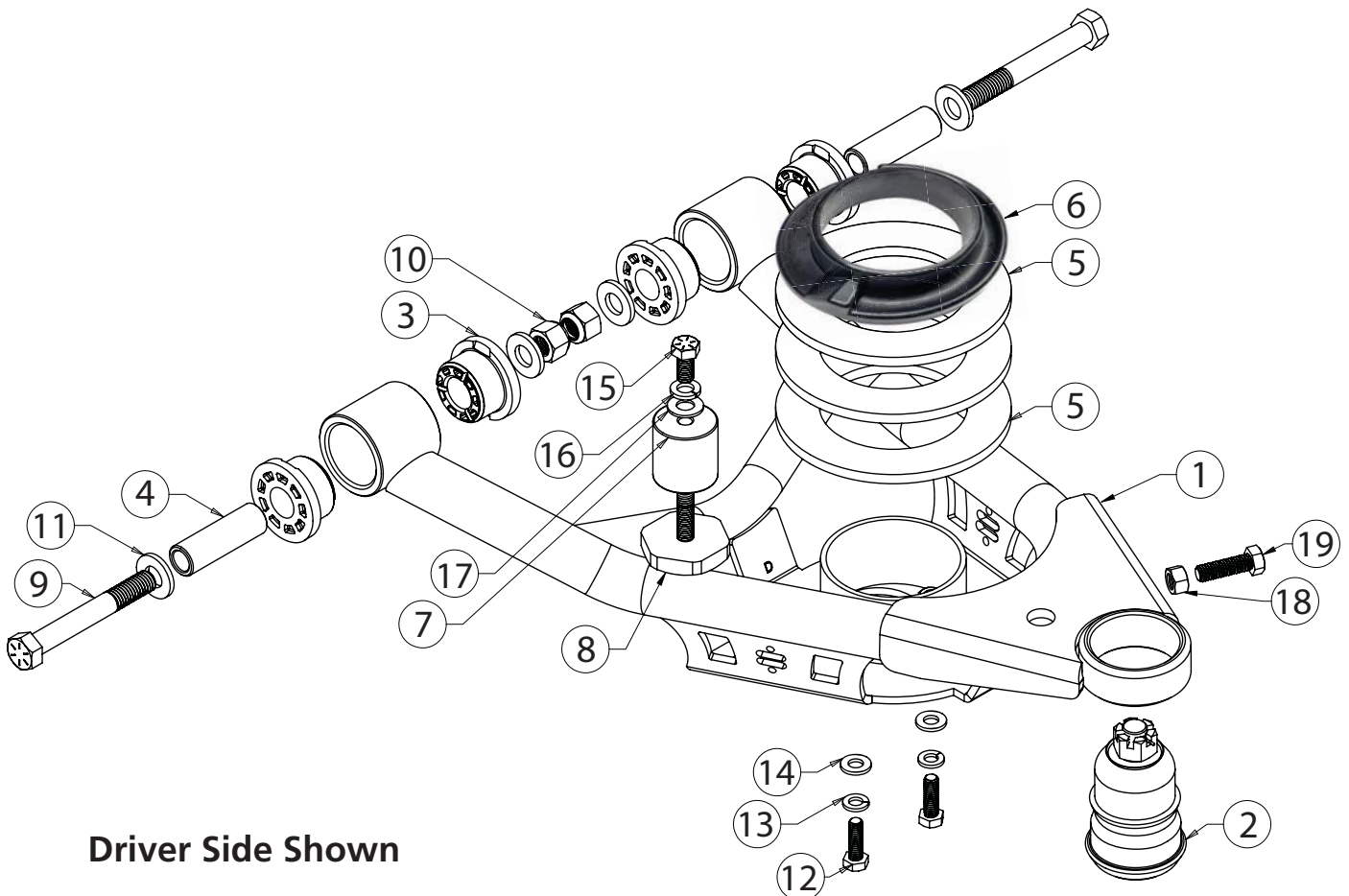

Driver Side Shown



### Hardware Kit .....# 99010191

Item #	Part #	Description	QTY	Item #	Part #	Description	QTY
<b>LOWER CONTROL ARM MOUNTING</b>				<b>BUMP STOPS</b>			
9	99501065	1/2"-13 x 3 3/4" Hex Bolt	4	15	99371065	3/8"-16 x 3/4" Hex Bolt	2
10	99502009	1/2"-13 Nylok Nut	4	16	99373002	3/8" Split Lock Washer	2
11	99503014	1/2" SAE Flat Washer	8	17	99373002	3/8" SAE Flat Washer	2
<b>SHOCK TO CONTROL ARM</b>					90002263	Red Loctite	1
12	99311030	5/16"-18 X 1" Hex Bolt	4	<b>STEERING STOP</b>			
13	99313005	5/16" Split Lock Washer	4	18	99372012	3/8"-16 Hex Nut	2
14	99313001	5/16" SAE Flat Washer	4	19	99371005	3/8"-16 x 1 1/4" Hex Bolt	2

## Getting Started.....

Congratulations on your purchase of the Ridetech F-Body StrongArms. These StrongArms have been designed to give your F-Body excellent handling along with a lifetime of enjoyment. Some of the key features of the StrongArms: ball joint angles have been optimized for the lowered ride height, delrin bushings are used to eliminate bushing deflection along with providing free suspension movement through the entire travel. The geometry has been optimized for excellent handling and driveability. The ride height can be adjusted using supplied shims. The delrin bushings are made from a material that is self lubricating so no grease zerks are needed.

## Ride Height Adjustment

We recommend measuring the car before starting the install. Measuring from the fender lip to the floor works well. This measurement along with the guide below will help determine if you need to shim the coil spring isolator.

These controls arms come with shims to help dial in the ride height to your liking. The kit contains (6) 1/4" spacers. By not running any spacers, these controls arms will lower the car approximately 1" at the wheel if using stock springs, 1 1/2" if using Ridetech StreetGrip springs. The guide below will assist you in determining what shim or shims to run to get the desired height.

### ADJUSTMENT GUIDE

STOCK SPRING height change @ fender lip	STREETGRIP SPRINGS height change @ fender lip	TOTAL SHIM THICKNESS	# OF SHIMS PER SIDE
+ 1/2"	0"	3/4"	3
0	-1/2"	1/2"	2
-1/2"	-1"	1/4"	1
-1"	-1 1/2"	0	0

**The shims install UNDER the coil spring isolator!!**



### Installation

1. Remove the entire lower control arms from the car. If you are replacing the upper control arms and spindle, remove them too. Refer to a factory service manual for the proper method.

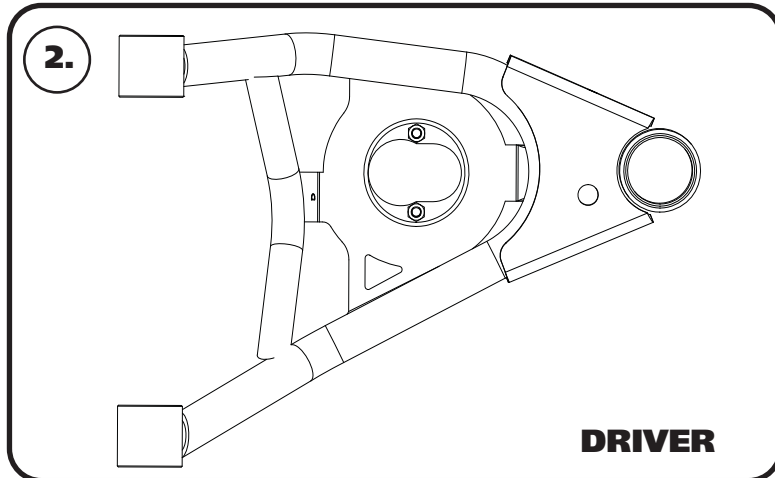

2. After removing the factory lower control arm, clean the bushing mounting surfaces on the frame. The control arms are marked "D" for Driver and "P" for Passenger. The ball joint pin points up and the sway bar mount is on the front side of the arm. **Image 2** shows a top view of the driver side control arm.



3. Insert the control arms into the OEM mounts.

**Note:** On some cars, the frame brackets may be pinched and will need to be spread back apart to allow the bushings to slide in.



4. Line up the OEM mounting holes with the through holes of the bushing sleeves. Install a 1/2" flat washer on each of (2) 1/2"-13 x 3 3/4" bolts. Insert the bolt/washers through the mounting holes. Install a 1/2" flat washer and 1/2"-13 nylok nut. Torque to 75 ft-lbs.



### Installation



5. The kit includes new bump stops. **Steps 5-8** will help guide you in the installation of the bump stops. The bump stop will be installed at the rear inner edge of the coil spring opening. **Image 5** shows the bump stop installed as a reference. A hole will need to be drilled to attach the bump stop to the frame.



6. Thread the bump stop into the aluminum spacer. Swing the control arm up to help determine the proper location of the bump stop. The bump stop needs to contact the front tube of the control arm with the aluminum spacer sitting flat against the frame. Mark the outside edges of the spacer as you will need to drill a 3/8" hole at the center of the location.



7. Use a 3/8" drill bit to drill a hole at the center of the bump stop spacer location.



### Installation



**8.** Install a 3/8" split lock washer & 3/8" flat washer on a 3/8"-16 x 3/4" bolt. Apply red loctite to the threads of the bolt. Insert the bolt in the drilled hole by reaching into the coil spring hole. Align the bump stop spacer with the bolt and thread it into the spacer. Tighten the bolt to 12 ft-lbs.



**9.** Use the guide on **Page 3** to determine what shims, if any, to use to achieve the desired ride height. Place the shims over the center ring. They will sit flat against the floor of the control arm.



**10.** Place the coil spring isolator over the ring of the control arm.



### Installation



**11.** Reinstall the coil spring, making sure the end of the coil spring is nested in the provision in the frame. Rotate the coil spring isolator to align it with the bottom of the coil spring.

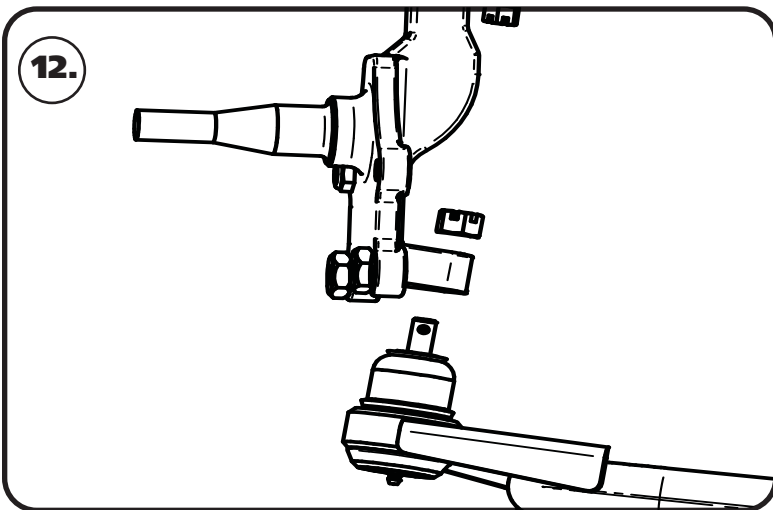

**12.** Attach the spindle to the control arms.

**Torque Specs:**

Lower ball joint - 65 ftlbs and tighten to line up cotter pin.

Install the cotter pin after tightening the ball joint nut.



**13.** Reinstall the shocks using the supplied 5/16" hardware to attach them to the new control arms. Torque to 17 ft-lbs.



### Installation



**14.** Thread the 3/8"-16 nut onto the 3/8"-16 x 1 1/4" bolt. Thread it into the rear hole of the ball joint plate. You will need to adjust the steering stop to suite your needs. This setting will vary depending on wheel and tire size and other suspension components.

**15.** Tighten all fasteners. If you are going to install the Ridetech SwayBar, now is a good time to do it.

### Torque Specifications

COMPONENTS	TORQUE
LOWER CONTROL ARM MOUNTING - 1/2"	75 FT-LBS
LOWER BALL JOINT (tighten to align cotter pin hole after torquing)	65 FT-LBS
BUMPSTOP SPACER TO FRAME	12 FT-LBS
STOCK TRUNNION TO CONTROL ARM	17 FT-LBS

### Alignment Specifications

**Suggested Alignment Specs:**

Camber: Street: -.5 degrees  
 Caster: Street: +3.0 to + 5.0 degrees  
 Toe: Street: 1/16" to 1/8" toe in