



1968-1974 GM X-Body StreetGrip

Front Components

| | |
|-----------|------------------------------|
| 11262351 | Front Dual Rate CoilSprings |
| 122149846 | Front HQ Series Shocks Front |
| 11169120 | Sway Bar |

Rear Components

| | |
|----------|-----------------------------|
| 11264799 | Composite Leaf Springs |
| 11265399 | Delrin Leaf Spring Bushings |
| 22189874 | Rear HQ Series Shocks |

Recommended Tools



1968-1974 GM X-Body Street Grip Installation Instructions

Table of contents

| | |
|-----------------|--|
| Page 2..... | Major Components and Hardware List |
| Page 3..... | Getting Started |
| Page 4-6..... | Delrin Bushings |
| Page 7-8..... | Tall Upper Ball Joint |
| Page 9..... | Front Dual Rate CoilSpring |
| Page 10-12..... | Front Sway Bar |
| Page 13-17..... | Composite Leaf Springs & Delrin Bushings |
| Page 17-20..... | Front and Rear HQ Series Shocks |

The majority of the StreetGrip components will be installed together. For example, the Front CoilSprings, Ball Joint, Control Arm Bushings and Shocks will be installed in conjunction with each other. On the rear, the CoilSprings and Shocks will be installed in conjunction with each other. The front Sway Bar will need to be attached to the frame **before** the rest of the components are installed.





Getting Started.....

Congratulations on your purchase of the Ridetech StreetGrip Kit. This system has been designed to give your Car excellent ride and handling along with a lifetime of enjoyment. Some of the key features of this Kit: Dual Rate CoilSprings, Composite Leaf Springs, Delrin Control Arm & Leaf Spring Bushings, Larger Swaybar with Delrin Liners and a Taller Upper Ball Joint.

The majority of the StreetGrip Components will be installed together. For example, the Front CoilSprings, Ball Joint, Control Arm Bushings and Shocks will be installed in conjunction with each other. On the rear, the Leaf Springs, Delrin Bushings and Shocks will be installed in conjunction with each other. The front Sway Bar will need to be ATTACHED to the frame BEFORE the rest of the front components are installed. The Sway Bar installation will be finished after the rest of the front components are installed

Front Suspension

The front components that will need to be installed are: Control Arm Bushings, Upper Ball Joints, Shocks, and CoilSprings. The Sway Bar needs to be ATTACHED to the frame BEFORE the rest of the front components are installed.

If you have never done this type of work before, we recommend getting a Factory Service Manual for proper procedures of disassembly and reassembly of the components for your car.

Rear Suspension

The rear components that will be installed are; rear Composite Leaf Springs, Delrin Leaf Spring Bushings, and rear HQ Series Shocks. The Composite Leaf Springs and Delrin Leaf Spring Bushings will be installed at the same time. The Delrin Leaf Spring Bushings are preinstalled in the Leaf Springs.

Alignment Specs

Anytime you change suspension components, you should have the car alignment checked.

Suggested Alignment Specs:

| | |
|---------|-------------------------------|
| Camber: | Street: -.5 degrees |
| Caster: | Street: +3.0 to + 5.0 degrees |
| Toe: | Street: 1/16" to 1/8" toe in |



Part # 11262350/11262351 - 1968-1974 X-Body Front CoilSpring



Recommended Tools



1968-1974 GM X-Body Front CoilSprings Installation Instructions

CoilSpring # 55480700 Small Block /**55518800** Big Block **Installation**

Front dual-rate spring will allow the vehicle to transition small road irregularities via a soft spring rate. When the vehicle compresses the spring far enough (through large bumps or cornering), it transitions to the firmer spring rate to control the bump or body roll. We have worked closely with Hyperco to develop custom dual rates to ensure the best ride possible.

The Front Control Arm Bushings and Upper Ball Joint should be installed before installing spring. The Front Suspension should be assembled with the Lower Ball Joint disconnected from the Spindle.

1. Compress the CoilSpring with an Internal Spring Compressor with the **CLOSE COILS TO THE BOTTOM**.
2. With the OEM Spring Removed, insert the CoilSpring into the Pocket. **SPECIAL ATTENTION NEEDS TO BE PLACED ON THE LOCATION OF THE ENDS OF THE SPRINGS TO MAKE SURE THEY ARE CLOKED CORRECTLY** . The end of the CoilSpring will nest into the receiver area of the Control Arm. If you line up the bottom, the top will be correct.
3. While holding the Spring in place, Slowly Jack the Lower Control Arm up until the Lower Ball Joint can be Engaged into the Spindle. Install the Castle Nut and Torque to 65 ftlbs then tighten as needed to align cotter pin hole. Install Cotter Pin. Once the Ball Joint is tight, remove the Spring Compressor.





Part # 11169120 - 1968-1974 GM X-Body Front Sway Bar



Recommended Tools

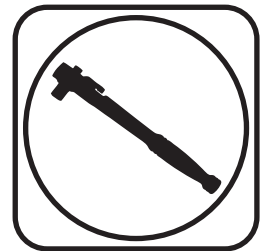

1968-1974 GM X-Body Front Sway Bar Installation Instructions

| | |
|-------------------|---------------------------------------|
| Table of contents | |
| Page 11..... | Included Components and Hardware List |
| Page 12..... | Sway Bar Installation |

ATTACH THE SWAYBAR TO THE FRAME BEFORE REINSTALLING THE FRONT SUSPENSION COMPONENTS.

| | |
|--------------------------------|----------|
| Hardware Torque Specifications | |
| 5/16"-16..... | 17 ftlbs |

Major ComponentsIn the box

| Part # | Description | QTY |
|-----------------|-------------------------|-----|
| 90001234 | Front Sway Bar | 1 |
| 90002929 | End Link Kit | 2 |
| 90001344 | Bushing Strap | 2 |
| 70015013 | Lined Sway Bar Bushing | 2 |
| HARDWARE | | |
| 99311030 | 5/16" -18 x 1" Hex Bolt | 4 |
| 99313001 | 5/16" SAE Flat Washer | 4 |
| 99313005 | 5/16" Split Lock Washer | 4 |

Getting Started.....

Note: This sway bar kit utilizes a anti-friction lining in the sway bar bushing. The lining allows the sway bar to move freely and quietly in the bushing. No lubrication is required.

1. Jack the vehicle up to a safe working height and support with jack stands. Make sure the jack stands are stable before working under the car.
2. Remove the driver front wheel/tires. It will be required to get the swaybar installed
3. Remove the stock sway bar.



4. Open the sway bar bushing at the split and slip it **OVER** the sway bar. Do this for both bushings



5. Insert the sway bar in the stock location. See below for installation tips.

Installation Tips: It is easier to install if you have the driver wheel/tire removed. Turning the steering wheel to the left also helps. It will require some twisting and turning of the bar to work it through the frame into the stock location. The swaybar needs to end up in the stock location with the ends above the lower control arms.



6.

6. Slip the bushing straps over the sway bar bushings. Line them up with the OEM mounting holes.



8.

7. Install a 5/16" lock washer & 5/16" flat washer on the 5/16" x 1" hex bolts.



8.

8. Torque the mounting hardware to 17 ftlbs.

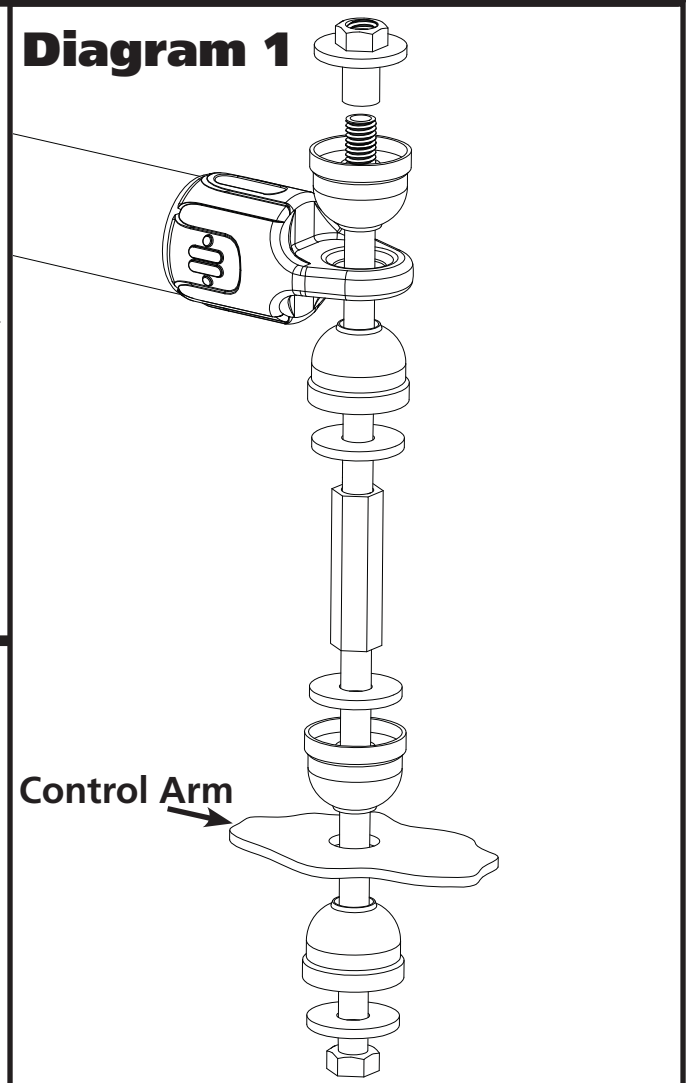

Diagram 1

Control Arm



9.

9. Install the end links using **Diagram 1** as a reference. Install both end links before tightening the end link hardware. Tighten the end link barrel nut until it is flush with the end of the bolt, and then tighten it 2 more complete rounds.



Part # 11264799 - 1968-1974 X-Body Composite Leaf Springs & Delrin Bushings

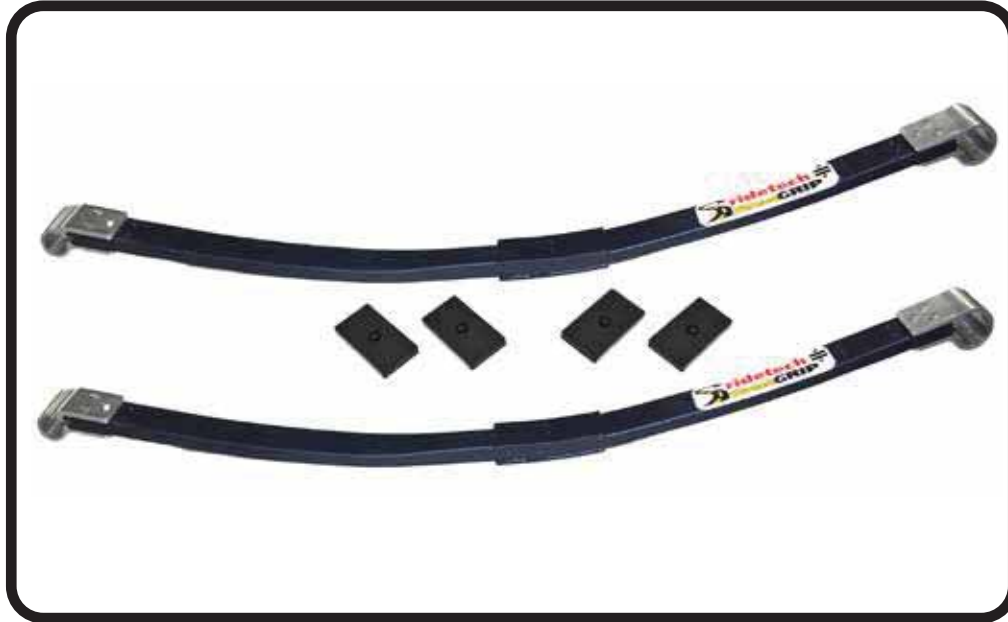

Recommended Tools

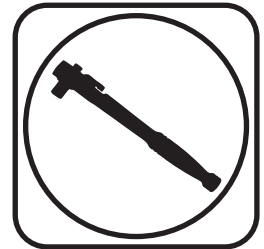

1968-1974 X-Body Composite Leaf Springs & Delrin Bushings

Installation Instructions

Table of contents

| | |
|--------------|---------------------------------------|
| Page 14..... | Included Components and Hardware List |
| Page 15..... | Leaf Spring Installation |
| Page 16..... | Clamping Plate Installation |
| Page 17..... | Finalizing Installation |

IT IS VERY IMPORTANT THAT NOTHING COMES IN CONTACT WITH THE COMPOSITE LEAF SPRINGS.

THESE COMPOSITE LEAF SPRINGS WILL ACCEPT OEM LEAF SPRING BUSHINGS. THE RIDETECH STREETGRIP KIT HAS THE DELRIN LEAF SPRING BUSHINGS (11265399) PREINSTALLED FOR MAXIMUM PERFORMANCE.





Major ComponentsIn the box

| Part # | Description | QTY |
|----------|---|-----|
| 90002907 | Leaf Spring Blade Assembly w/70012426, 70012427, & 90000526 installed | 2 |
| 90002497 | Leaf Spring Clamping Plates | 4 |
| 90002526 | Mono Leaf Clamping Plate | 2 |
| 70012428 | Delrin Rear Shackle Frame Bushing | 4 |
| 90000526 | Inner Bushing Sleeve | 2 |
| 90002496 | Shackle Plate | 4 |
| | Hardware | |
| 99501035 | 1/2"-13 x 5" Hex Bolt GR8 | 6 |
| 99502009 | 1/2"-13 Nylok Nut GR 8 | 6 |
| 99436001 | 7/16"-20 U Bolt | 2 |
| 99431015 | 7/16"-20 x 2 1/4" Hex Bolt | 4 |
| 99432009 | 7/16"-20 High Nut | 8 |
| 99433005 | 7/16" SAE Flat Washer | 8 |
| 99371050 | 3/8"-16 x 1 1/2" Conical Body Bolt | 6 |
| 99372009 | 3/8"-16 U-Nut | 6 |

Getting Started.....

IT IS VERY IMPORTANT THAT NOTHING COMES IN CONTACT WITH THE LEAF SPRING.

THIS LEAF SPRING KIT WILL WORK WITH MONO LEAF OR MULTI LEAF DIFFERENTIALS, BUT THE INSTALLATION PROCESS VARIES BETWEEN THE TWO. THESE INSTRUCTIONS COVER BOTH SETUPS, BE AWARE THAT YOU ARE DOING THE CORRECT STEPS FOR YOUR DIFFERENTIAL.

1. Jack the car up and support it by the frame rails. You will need to raise and lower the rear differential with a jack to ease installation. With the car supported by the frame, put the jack underneath the rear end housing and raise the jack up just enough to support the differential. Disconnect the bottom of the shock and remove the rear leaf springs. Retain the OEM hardware. The OEM frame bushings will need to be removed and all debris removed from the holes to ease installation of the bushings.

2. The Shackle Plates and Hardware can be used to push the rear bushings into the frame location. Start the bushings into the frame and insert a 1/2"-13 bolt into a shackle plate. Insert the bolt/shackle plate into the bushing and install a second shackle plate on the bolt sticking through the bushing. Install a 1/2"-13 nut and tighten until the bushings bottom out on the frame. Remove the shackle plates and install the inner sleeve.



Leaf Spring Installation

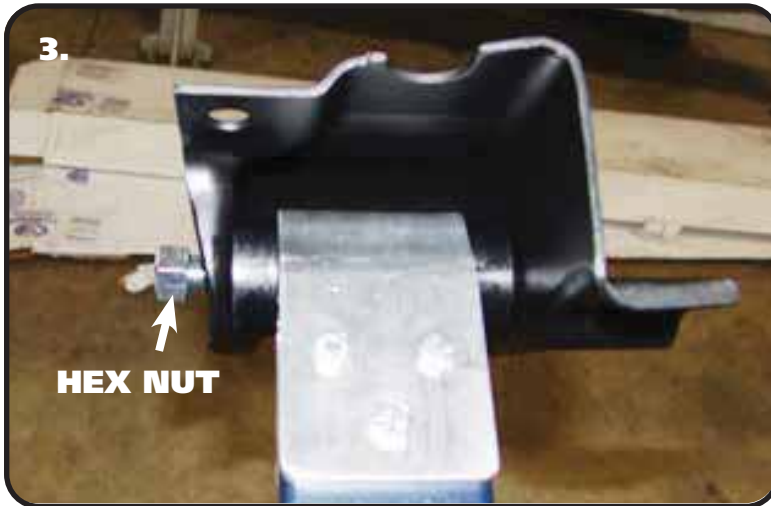

3. Bolt the **LARGE BUSHING END** of the Composite Leaf Spring into the OEM front leaf spring mount using a 1/2"-13 x 5" Hex Bolt and 1/2"-13 Nylok Nut. The Bolt must be installed with the threads pointing to the **OUTSIDE** of the car. Diagram #3 is the correct orientation.

NOTE: Front spring pocket must be removed from car before installing new springs. New Hardware is supplied in kit.

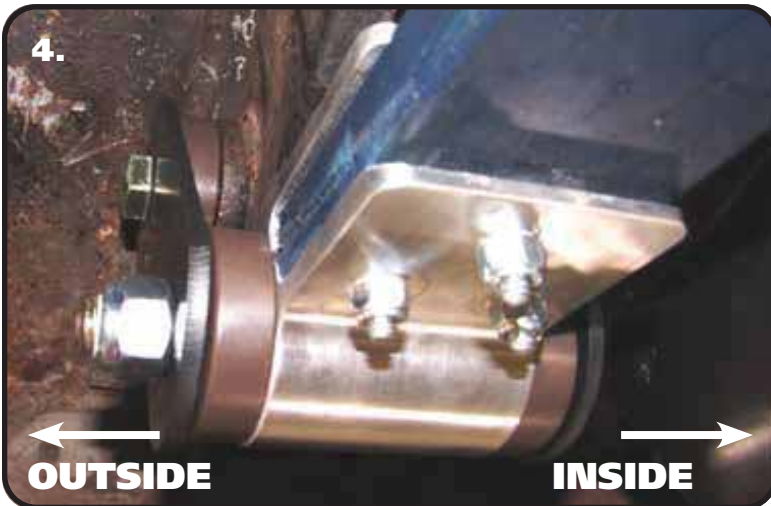

4. Attach the rear of the Composite Leaf Spring to the rear mount. If you are using the Ridetech Delrin Bushings, new Shackles and Hardware is supplied with them. Attach a Shackle Plate to each side of the Frame Bushing using a 1/2"-13 x 5" Bolt (WITH THREADS POINTING TO INSIDE OF CAR) and 1/2"-13 Nylok Nut. Do not tighten. Align the remaining bolt holes in the shackle plates with the sleeve in the rear Leaf Spring bushing. Install a 1/2"-13 x 5" Bolt (WITH THREADS POINTING TO OUTSIDE OF CAR) and 1/2"-13 Nylok Nut. Do Not tighten hardware, it will get tightened later.



5. Swing the Leaf Spring up and attached the front mount to the car using the supplied 3/8"-16 x 1 1/2" Conical Body Bolts and U-Nuts. Tighten Hardware

Note: You may have to jack the rear differential up enough to swing the leaf spring in place.

IF YOU HAVE A MONO LEAF DIFFERENTIAL, SKIP TO STEP 8.



CLAMPING PLATE INSTALLATION

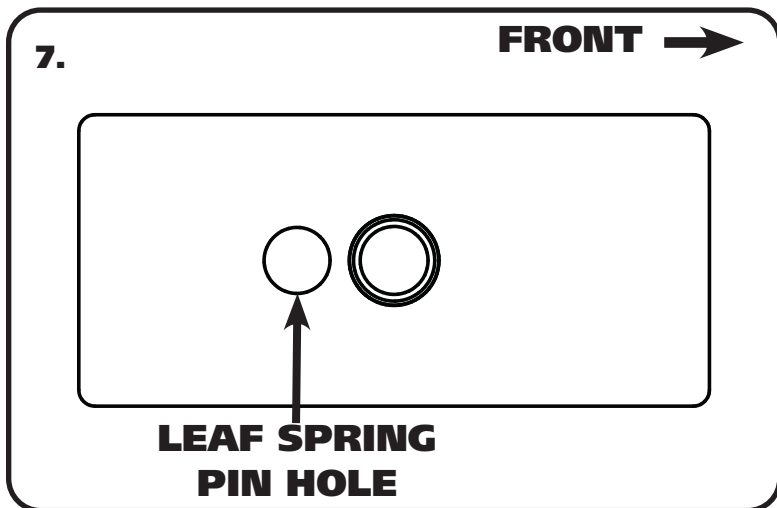

7. Images 7 & 8

8.

9. Image 8 & 9

Note:

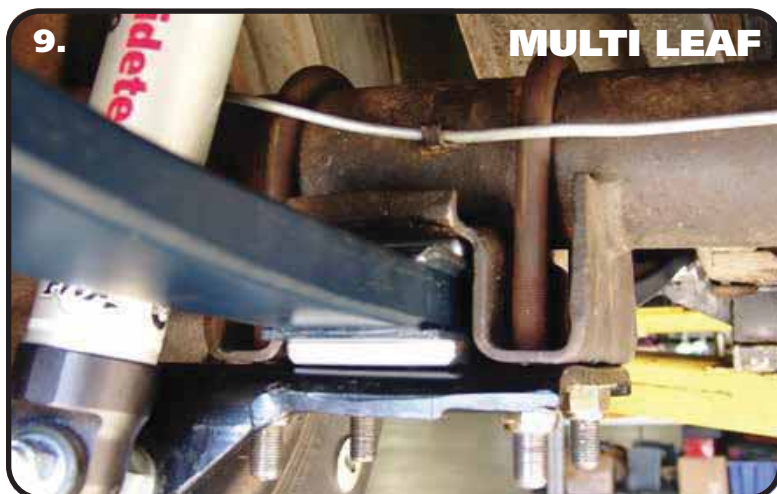
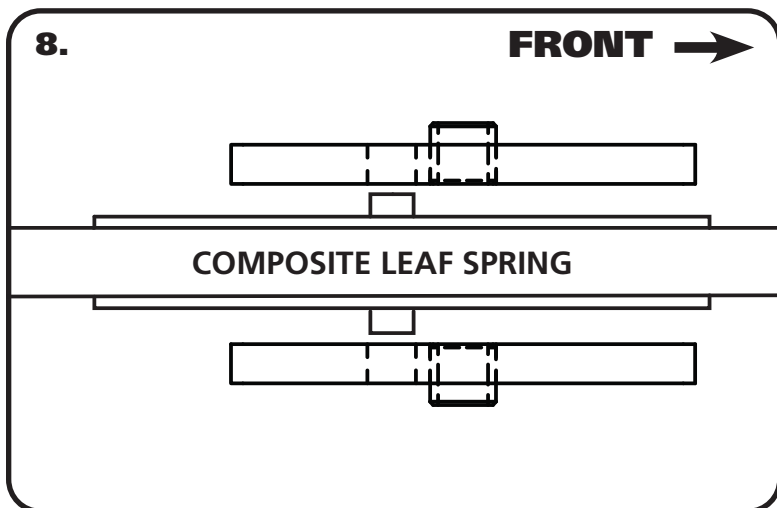



Finalizing Installation

10. Tighten the Bushing hardware, torquing it to 75 ftlbs. The Delrin Bushings will not bind, so it isn't necessary to have the car at ride height. If using OEM style rubber bushings, the car will need to be on the ground at ride height before tighten the bushing hardware.
11. Install the Ridetech HQ Series shocks. Refer to the shock instructions.
12. **DOUBLE CHECK TO MAKE SURE NOTHING IS COMING INTO CONTACT WITH THE LEAF SPRING.**

Front & Rear HQ Series Shocks



Recommended Tools

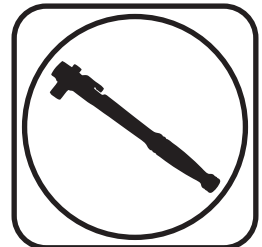

Front & Rear HQ Series Installation Instructions

Table of contents

| | | |
|------|---------|---------------------------------------|
| Page | 18..... | Rear Shock Installation |
| Page | 19..... | Front Shock Installation |
| Page | 20..... | Front Shock Installation & Adjustment |



Rear - Part # 22189874 - 7.55" HQ Series Shocks

Major ComponentsIn the box

| Part # | Description | QTY |
|------------|--|-----|
| 986-10-020 | 7.55" Stroke Shock | 2 |
| 70011139 | 5/8" ID Shock Bushing (Installed in Shock) | 2 |
| 90002068 | Wide Trunnion (Installed in Shock) | 2 |
| 70011138 | 3/4" ID Shock Bushing (Installed in Shock) | 2 |
| 70011194 | 7/16" ID Shock Sleeve (Installed in Shock) | 2 |
| 90002102 | 1/2" ID Shock Sleeve | 2 |

Shock Installation

The Rear Shocks will be installed in conjunction with the Rear Leaf Springs.

1.

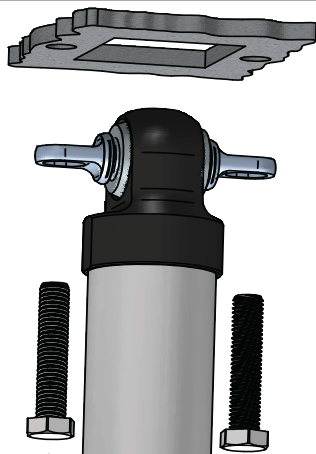

1. With the OEM Shock removed, install the Ridetech shock. Attach the Top of the Shock in the OEM location using the OEM Hardware. It may be necessary to rotate the Trunnion to get it in the correct position. This can be done by sticking a screwdriver in one of the slots and spinning the trunnion in the shock bushing.

2.

OEM SHOCK MOUNT

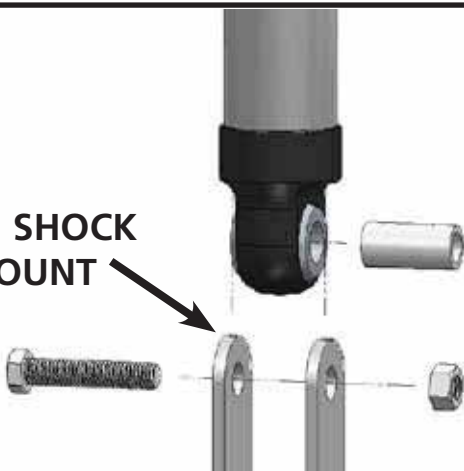

2. Attach the Bottom of the Shock in the OEM Location using the OEM Hardware. The Lower Shock is Bolted to the Lower OEM Mount using the supplied Shock Sleeve. These cars can have either a 7/16" or 1/2" Bolt, both inner sleeves are supplied in the kit. The 7/16" comes installed in the shock. If the 1/2" is needed, press it in using a bench vise or something similar.



Front- Part #22149846 - 4.75" Stroke HQ Series Shocks

Major ComponentsIn the box

| Part # | Description | QTY |
|------------|--|-----|
| 986-10-042 | 4.75" Stroke Shock | 2 |
| 70011139 | 5/8" ID Shock Bushing (Installed in Shock) | 2 |
| 90002069 | Standard Trunnion (Installed in Shock) | 2 |
| 70011141 | Bushing Support Washer | 4 |
| 70011140 | Stem Bushing | 4 |
| 99372006 | 3/8"-24 Thin Jam Nut | 4 |

Due to manufacturing tolerances it may be necessary to clearance the Control Arm to get the Shock through the Control Arm opening.

Shock Installation

Before installing the Shocks, the Control Arm Bushings, Upper Ball Joint, and CoilSprings should be installed.

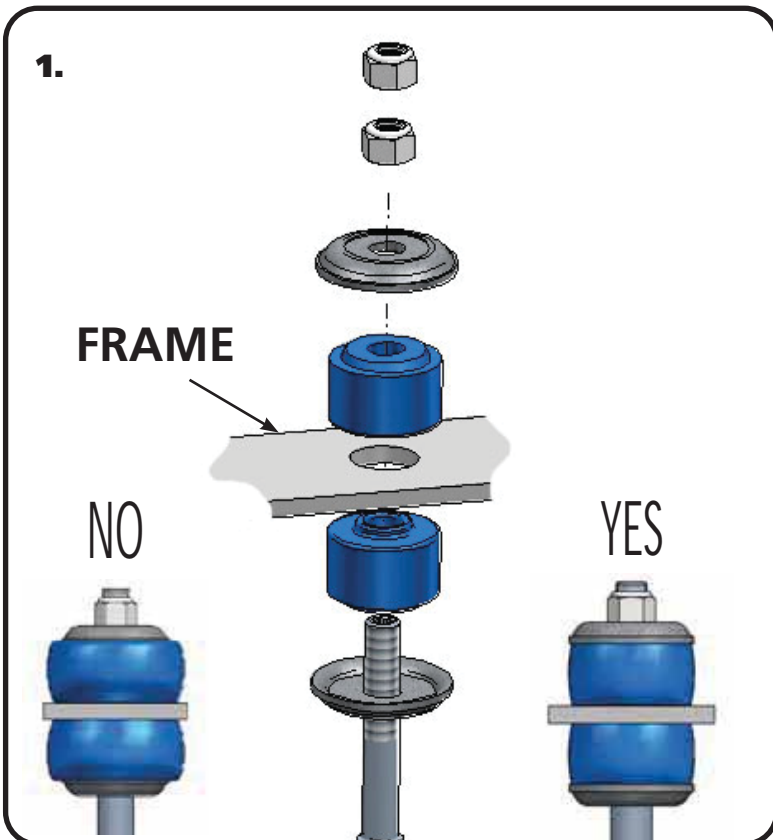

1. With the OEM shock removed, install the Ridetech shock. Remove the adjuster knob by loosening the set screw using the supplied Hex Key. Install a Bushing Support Washer on to the shock shaft followed by a Shock Stem Bushing. Insert the assembly through the factory shock hole in the frame. With the shock stud sticking through the frame, install a Shock Stem Bushing on to the shock stud followed with a Bushing Support Washer. Install a 3/8"-24 Thin Jam nut onto the threads and tighten to 35 inlbs. The Bushing should be tight, but not to the point that the bushing is bulging past the Support Washer. Install the 2nd 3/8"-24 Thin Jam nut and tighten it against the first nut. Reinstall the Adjuster Knob, align the set screw with the FLAT side of the adjuster shaft that is sticking out of the top of the shock shaft.

NOTE: It may be necessary to remove the OEM Speed Nuts from the Control Arm to allow room for the Shock to slide through the opening in the Control Arm. The Speed Nuts can be reinstalled after the Shock is in position.



Shock Installation and Adjustment

2.

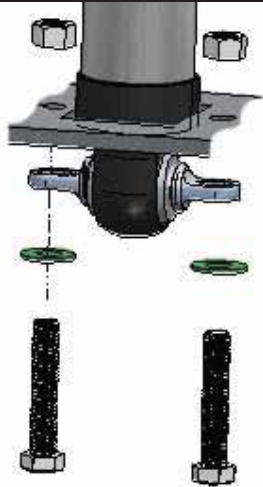

2. Attach the Trunnion to the OEM Control arm using the OEM hardware. It may be necessary to rotate the Trunnion to get it in the correct position. This can be done by sticking a screwdriver in one of the slots and spinning the trunnion in the shock bushing.

Shock adjustment 101- Single Adjustable

Rebound Adjustment:

How to adjust your new shocks

The rebound adjustment knob is located on the top of the shock absorber protruding from the eyelet or stud top. You must first begin at the ZERO setting, then set the shock to a street setting of 12 or handling setting of 8.



-Begin with the shocks adjusted to the ZERO rebound position (full stiff). Do this by rotating the rebound adjuster knob clockwise until it stops.

-Now turn the rebound adjuster knob counter clockwise 12 clicks. This sets the shock at 12 for a street setting. If you are after a handling setting only go 8 clicks.

Take the vehicle for a test drive.



-if you are satisfied with the ride quality, do not do anything, you are set!

-if the vehicle is too soft increase the damping effect by rotating the rebound knob clockwise 3 additional clicks.

-if the vehicle is too stiff rotate the rebound adjustment knob counter clock wise 2 clicks and you are set!

Take the vehicle for another test drive and repeat the above steps until the ride quality is satisfactory.

Note:

One end of the vehicle will likely reach the desired setting before the other end. If this happens stop adjusting the satisfied end and keep adjusting the unsatisfied end until the overall ride quality is satisfactory.