

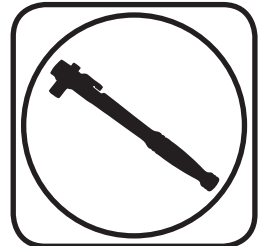

Part # 11369590 - 1973-1987 C10 Delrin Control Arm Bushings



Recommended Tools



1973-1987 C10 Delrin Control Arm Bushings Installation Instructions

Table of contents

Page 2.....	Included components and Hardware List
Page 3.....	Delrin Bushing Installation
Page 4.....	Upper Bushing & Control Arm Installation





Major ComponentsIn the box

Part #	Description	QTY
70012852	Upper Control Arm Bushing Outer Shell	4
70012853	Upper Bushing Inner Sleeve	4
70012851	Delrin Upper Control Arm Bushing	4
70012855	Lower Control Arm Bushing Outer Shell	4
70012856	Lower Bushing Inner Sleeve	4
70012854	Delrin Lower Control Arm Bushing	4

Getting Started.....

The Front Control Arms will need to be removed from the truck. Mark the shims, they will be reinstalled in the same location they were removed from. Retain the OEM hardware for reassembly. Refer to the Factory Service Manual for disassembly procedure.

This C-10 Bushing Kit contains: 4 Upper Control Arm Bushing Assemblies, and 4 Lower Control Arm Bushing Assemblies. The Upper Bushings are all the same and the Lower Bushings are the same. Be sure to match the correct Bushings with the correct locations. This kit reuses the OEM Cross Shafts.

1. Measure the Outside Width of the Control Arms and write it down before starting Bushing Removal. You will use this Dimension to check the Control Arms after the new Delrin Bushings are installed.

The Cross Shaft must be put in place and in the correct orientation before installing the Bushing Shells in the Upper Control Arms.

There are several ways the Delrin Bushing Assemblies can be installed. No matter the method used, the Control Arm needs to be **SUPPORTED** to keep from distorting the Control Arm. We recommend cutting spacers to go inside the Control Arms when pressing in the Bushings.

Note: The Delrin is self-lubricating, no lubricant is needed.

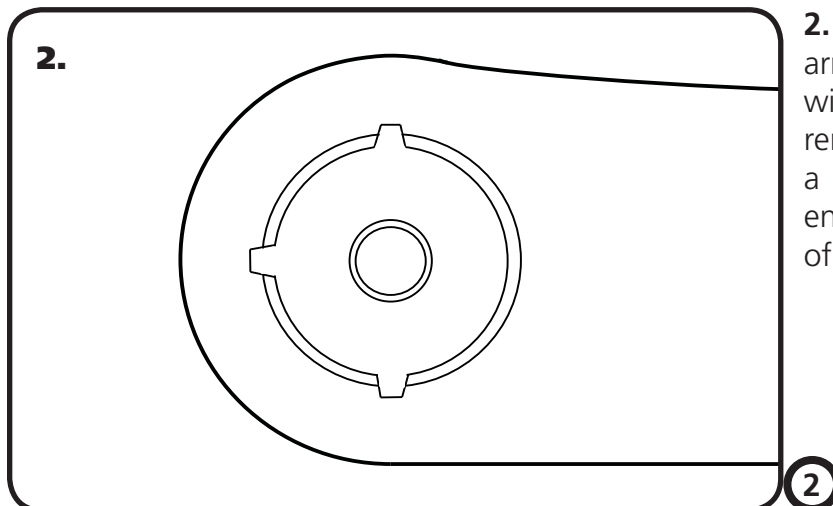

2. The OEM bushings in the Lower Control arm are staked outward. These Staked areas will need to be knocked inward to be able to remove the bushings. This can be done with a hammer and chisel. Knock the areas in far enough that they will clear the inside diameter of the bushing hole.



Delrin Bushing Installation



3. LOWER CONTROL ARM: The Lower Control Arm's Outer Shells can be installed before the Cross Shaft is installed, it will slide through the Shells. We used a C-clamp style tool to install our bushings. Most auto parts stores have these as a loan-a-tool. When pressing the Outer Shell into the arm, **be sure to support the inside of the arm to keep it from crushing.** Press the shell in until it bottoms against the control arm.

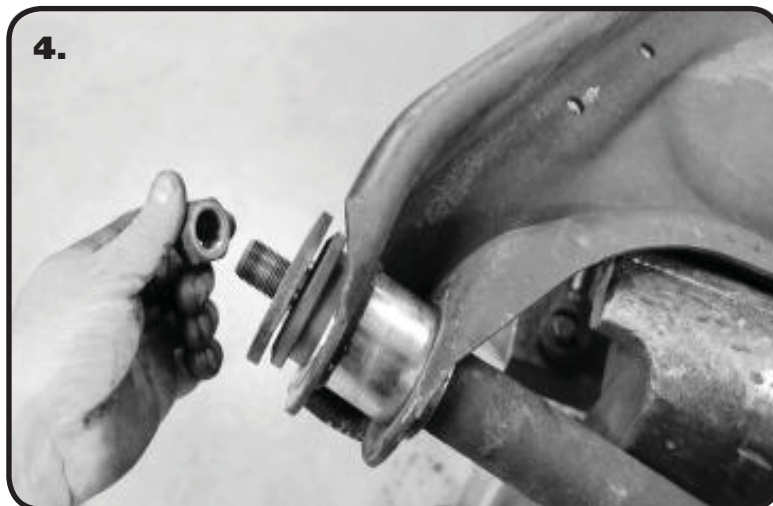

4. Insert the cross shaft into the control arm by sliding it through the Outer Shells installed in the arms. Push the Inner Sleeve into the Delrin Bushing. Push the Delrin Bushing/Inner Sleeve assembly into the Outer Shells. They will go in partially. Install the OEM washer and nut on each end of the cross shaft. Tighten the Hardware on each end until the Delrin Bushings are bottomed out against the lip of the Outer Shell installed in the control arm.



5. UPPER CONTROL ARM: The Upper Control arm has an inner washer on the cross shaft that needs to be removed before installing the Delrin Bushings.



Upper Bushing & Control Arm Installation



6. When installing the 1st Shell, use a piece of metal or strong wood to drive the Outer Shell into the Control Arm until the Shell stops. **The Shell will stop against the STEP in the Shell, not the flange, part of the Shell will be sticking out of the control arm. Install the Cross Shaft before installing the 2nd Shell.** You will need to use a piece of pipe or a deep socket to install the 2nd Shell due to the shaft sticking through. Using the pipe or socket, drive the 2nd Outer Shell in until it bottoms.

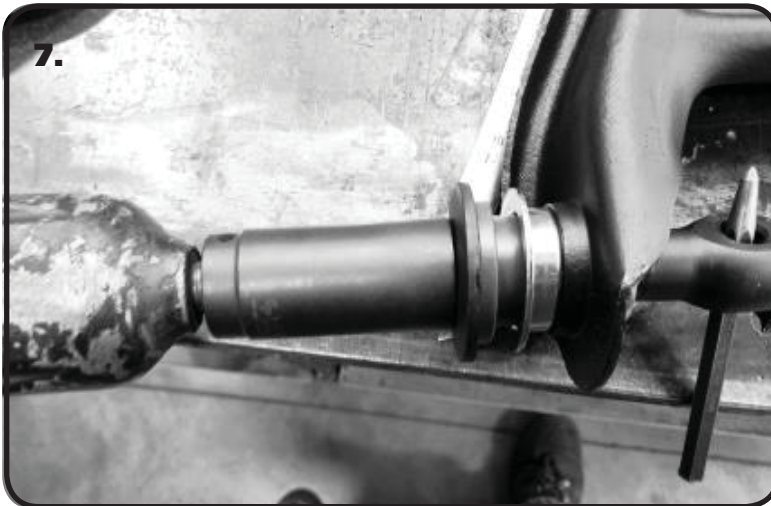

7. Push the Inner Sleeve into the Delrin Bushing. Push the Delrin Bushing/Inner Sleeve assembly into the Outer Shells. They will go in partially. Install the OEM washer and nut on each end of the cross shaft. Tighten the Hardware on each end until the Delrin Bushings are bottomed out against the lip of the Outer Shell installed in the control arm.

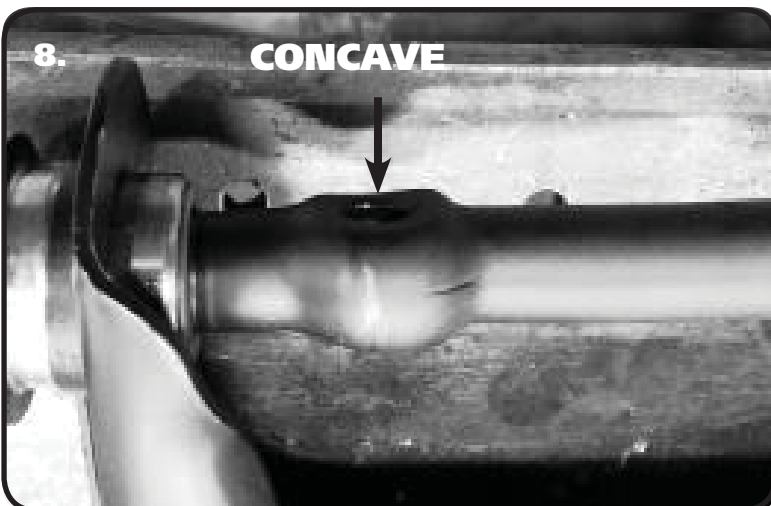

8. Reattach Control Arms to Truck. Use the OEM Hardware to attach the Lower making sure the Locating Pin for the lower cross shaft is in the hole. The Pin in the Cross Shaft Saddle will locate into the Holes. The Upper Control Arm Cross Shaft has a Concave area around the bolt hole. This Concave needs to go against the Convex Spacer on the Cross Shaft Bolts. The shims go behind the convex spacer. Reattach the Upper Control arms using the OEM Hardware and installing the Alignment Shims.