



350 S. St. Charles St. Jasper, In. 47546
Ph. 812.482.2932 Fax 812.634.6632

www.ridetech.com

Part # 30142000
2000 Series RidePro 2 Way Compressor System
3 Gallon Tank – Analog Gauges

Components:

| | | |
|---|----------|--|
| 1 | 31920014 | Air compressor |
| 1 | 31192500 | RidePro 4 Way analog control panel with rocker switches (Black Face) |
| 1 | 31913100 | 3 gallon aluminum tank |
| 1 | 31932501 | RidePro 4 Way valve block |
| 1 | 31980005 | Pressure switch – 135 On / 150 Off |

Wiring & Hardware:

| | | |
|---|----------|---|
| 1 | 90001924 | Fuse holder |
| 1 | 90001922 | 20 Amp fuse |
| 1 | 31900036 | Wiring harness - Control panel to valve |
| 3 | 99104001 | 10-24 x 1" phillips screw |
| 3 | 99102002 | 10-24 Nylok nut |
| 3 | 99103001 | #10 SAE flat washer |
| 1 | 90001916 | #10 x 5/16 ring terminal |
| 1 | 90001913 | 12-10 butt connector |
| 2 | 90001918 | Female spade connector |

Airline & Fittings:

| | | |
|---|----------|---|
| 2 | 31940002 | 1/4" DOT airline - 30 ft. roll - valve block to gauges |
| 1 | 31940000 | 1/8" DOT airline - 25 ft. roll - valve block to gauges |
| 1 | 31952150 | 1/8"npt x 1/4" tube female straight - compressor |
| 1 | 31957003 | 2" Brass Nipple - compressor |
| 4 | 31954201 | 1/4" npt x 1/4" tube Elbow airline fitting |
| 5 | 31954000 | 1/4" npt x 1/4" tube Straight airline fitting |
| 2 | 31952000 | 1/8" npt x 1/8" tube Straight fitting - manifold to gauge fitting |
| 1 | 31957004 | 1/4" npt plug - plug unused supply port |
| 2 | 31954400 | 1/4" airline T - DOT |



350 S. St. Charles St. Jasper, In. 47546

Ph. 812.482.2932 Fax 812.634.6632

www.ridetech.com

ARC2000 Compressor System Instructions

These are some general guidelines to follow when installing your new RidePro air control system. Depending on the vehicle there are many different ways to plumb the system. Start out by planning a lay out of where you want everything to be mounted. Typically we try to keep the compressor, solenoids, tank, and sending units in a central location, but they can be separated to suit your needs.

Mounting the Compressor/ Pressure Switch

- **Remove the negative battery cable before beginning installation.**
- All of our compressors are sealed for moisture and dust resistance so they can be mounted anywhere on the vehicle. Although it is best to mount it in a place out of direct contact with rain and snow. It is OK to mount it underneath the vehicle but keep it inside the frame rails away from water and debris thrown off the tire.
- This is a dry compressor; therefore it is maintenance free and can be mounted in any position.
- It is best if mounted to something solid to reduce vibration and noise. If mounting it to sheet metal or the bed of a truck, use sound deadening material between the compressor and the mounting surface.
- Use the rubber grommets supplied on the feet of the compressor to reduce vibration.
- Apply thread sealant to the pressure switch and compressor T and screw into the tank.
- One spade of the pressure switch will connect to power the other to the red wire on the compressor.

Mounting the Air Tank

- The air tank can be mounted anywhere on the vehicle in any position.
- If your air system is used frequently you may want to remove the tank once a season to drain any excessive accumulation of water.

Mounting the RidePro Air Valves

- The valves, like the compressor, are sealed and can be mounted in the same locations. Although if the vehicle will be exposed to freezing temperatures it is a good idea to mount them in the engine bay if possible to reduce the possibility of freezing.
- They can be mounted in any position.
- Mount the valves higher than the tank to avoid moisture build up. This could cause the air pressure sensors to give a faulty reading.
- Attach the ground strap to a good, clean ground (preferably the frame).
- The exhaust port will be left open.
- The valve is held closed with the pressure in the tank. If tank pressure drops below air spring pressure they will equalize deflating all 4 air springs.

Wiring Harness

- The red wire on the harness will connect to 12 v.
- The gray wire will then supply the gauge light 12v. Or the gauge light can be powered with illumination.

Routing the Airline and Fittings

- Make all airline cuts with a razor or tubing cutter. It must be clean and straight or it will not seal.
- All fittings are DOT approved push-to-connect style. They are very simple to use and are reusable. Firmly push the airline into the fitting to attach. To release the airline pull the collar on the fitting back towards the fitting and pull the airline out.
- Use thread sealant on all fittings.
- Do not over tighten the fittings. This could result in breaking the fitting or damaging the air spring.
- All of our airlines are DOT approved so they are very strong. But keep them away from any sharp edges. Also when passing through a hole in the frame use a grommet.
- Keep away from intense heat including mufflers and exhaust manifolds.
- Use zip ties or other fasteners to secure the airline.

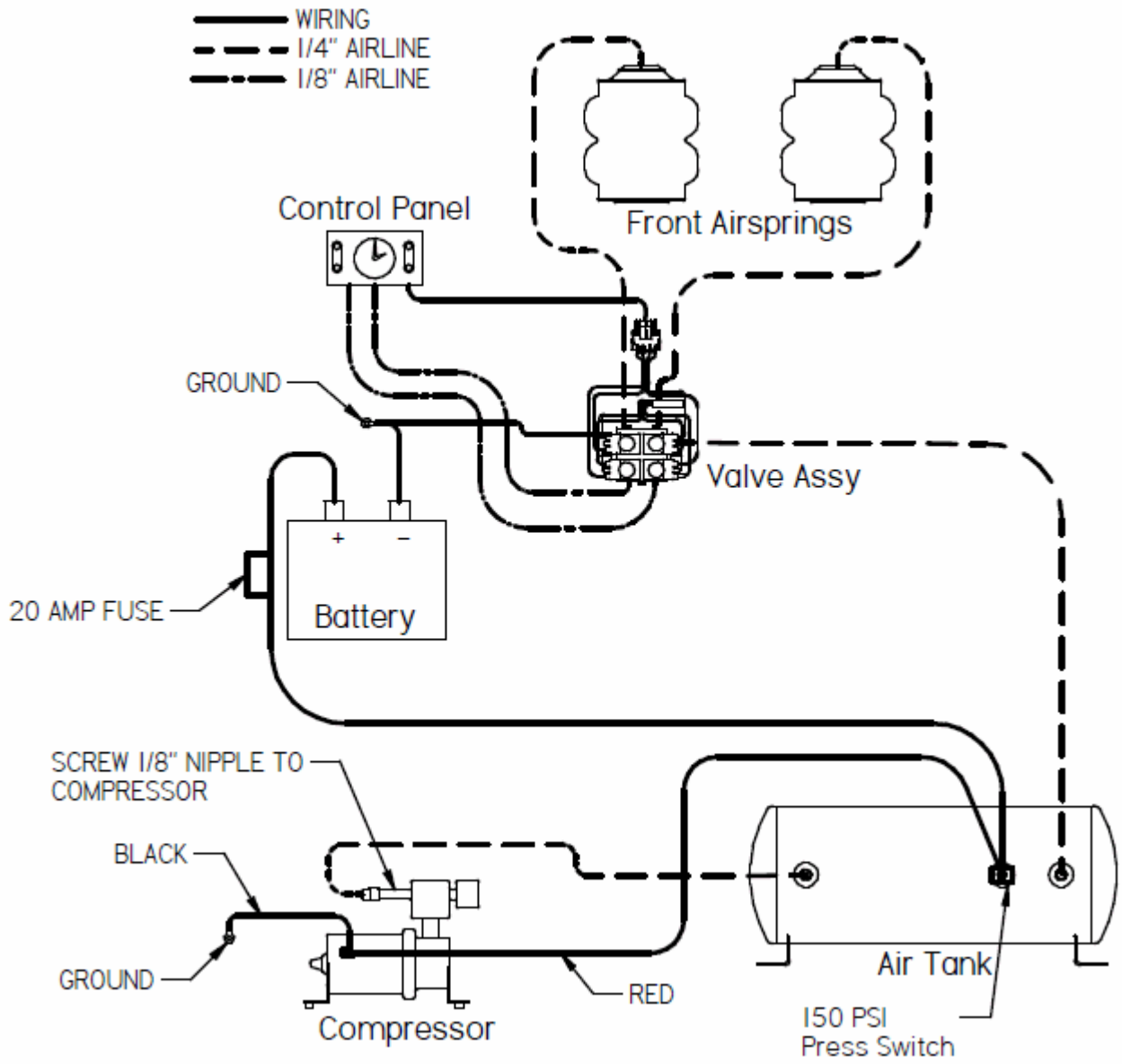

Wiring at control panel:

Gray connects to gauge light

Red connects to "key on" power at fuse box