

# Classic Update Series

1974-77 Camaro

## START HERE !

PLEASE READ THIS BEFORE STARTING INSTALLATION !

This wiring kit is designed for ease of installation. Please read the guidelines below, BEFORE STARTING your installation to guarantee a successful job. Use an appropriate crimping tool which folds the wings of the open barrel terminals down into the wire as shown below. ALL TERMINALS THAT YOU INSTALL SHOULD BE PROPERLY SOLDERED. Our factory crimped terminations are installed by GM approved five ton presses, and soldering these terminations is not necessary. AAW offers a great terminal crimping video entitled "Proper Crimping Video". It can be viewed by visting YouTube. Type the following address into your web browser to go directly to the video: [www.youtube.com/watch?v=8u\\_EkMsiomy](http://www.youtube.com/watch?v=8u_EkMsiomy).



AS THIS HARNESS IS DESIGNED FOR USE IN A MODIFIED CAR REQUIRING A HIGHER RATE OF CHARGE WITH AN INTERNALLY REGULATED "SI" OR SINGLE WIRE STYLE ALTERNATOR. IT CAN ALSO BE USED WITH THE LATER "CS" AND "CS-D" UNITS BY USING ALTERNATOR ADAPTERS WHICH ARE SOLD SEPARATELY. CONTACT AAW OR YOUR FAVORITE DEALER FOR THE PROPER ALTERNATOR ADAPTER FOR YOUR CAR.

### STEP 1: DISCONNECT YOUR BATTERY:

Disconnect the battery before installing the wiring kit to prevent any accidental shorting caused by loose bare wire ends.

### STEP 2: START INSTALLING KIT:

This kit is broken down into individual steps that are identified by a letter printed on the instruction sheets visible through each bag. These letters are the order of operation for installing your kit. Start with the bag letter G , then H , etc. The order of installation is shown below.

G 510568 Dash Harness Kit  
H 510569 Instrument Cluster Kit  
J 510570 Engine Kit  
L 510571 Front Light Kit  
M 510572 Rear Body Kit  
N 500708 Courtesy Light Kit

### STEP 3: RECONNECT YOUR BATTERY:

When you have completed the installation and are ready to reconnect the battery, make sure that the following electrical system grounds are in place:

A. Battery is grounded to the ENGINE BLOCK.  
B. Battery is grounded to the frame.  
C. Engine block is grounded to the frame.  
D. Body is grounded to the frame.

### STEP 4: CHECK ALL ELECTRICAL FUNCTIONS:

Any non-functioning items should be checked for proper installation. Any problems with your wiring and electrical circuit functions should be addressed to American Autowire Systems, Inc. as soon as possible to avoid any warranty problems.

If you have any questions concerning this or any of our products, please feel free to call us at 1-800-482-WIRE.

AMERICAN AUTOWIRE MAKES IT EASY !!

page 1

We carry many accessories for your 1974-1977 Camaro

p/n R0067108  
OEM style non-stick harness tape



p/n 01997938US (1969-76)  
OEM style turn signal switch



p/n 38131  
Breakerless Ignition Module,  
GM V-8 POINT CONVERSION KIT



p/n 03943657 (1969-81)  
Muncie 4 speed back up lamp switch



p/n 500523  
OEM large terminal and double  
crimping tool (20-8 gauge)



p/n 500649  
Multi-crimp tool (20-14 gauge)



p/n 01242101 (1974-77)  
pedal mounted T400 kickdown switch



p/n 36285 (1974)  
p/n 36286 (1975)  
p/n 36287 (1976)  
p/n 36288 (1977)  
Factory assembly manuals  
(It's what they used on the assembly  
line to build your Camaro!)

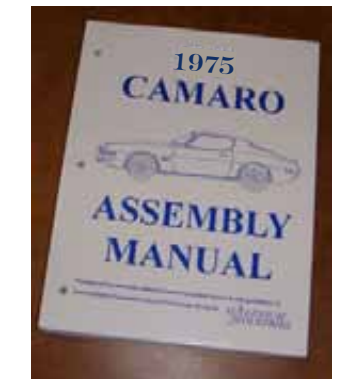

[www.americanautowire.com](http://www.americanautowire.com) 856-933-0801

Classic Update  
Series

1974-77 Camaro

510567

© COPYRIGHT 2004 American Autowire / Factory-Fit  
Used with express permission of  
American Autowire / Factory-Fit  
92970767 instruction sheet rev. 0.0 8/19/2014

# Classic Update Series

## 1974-77 Camaro



www.americanautowire.com 856-933-0801

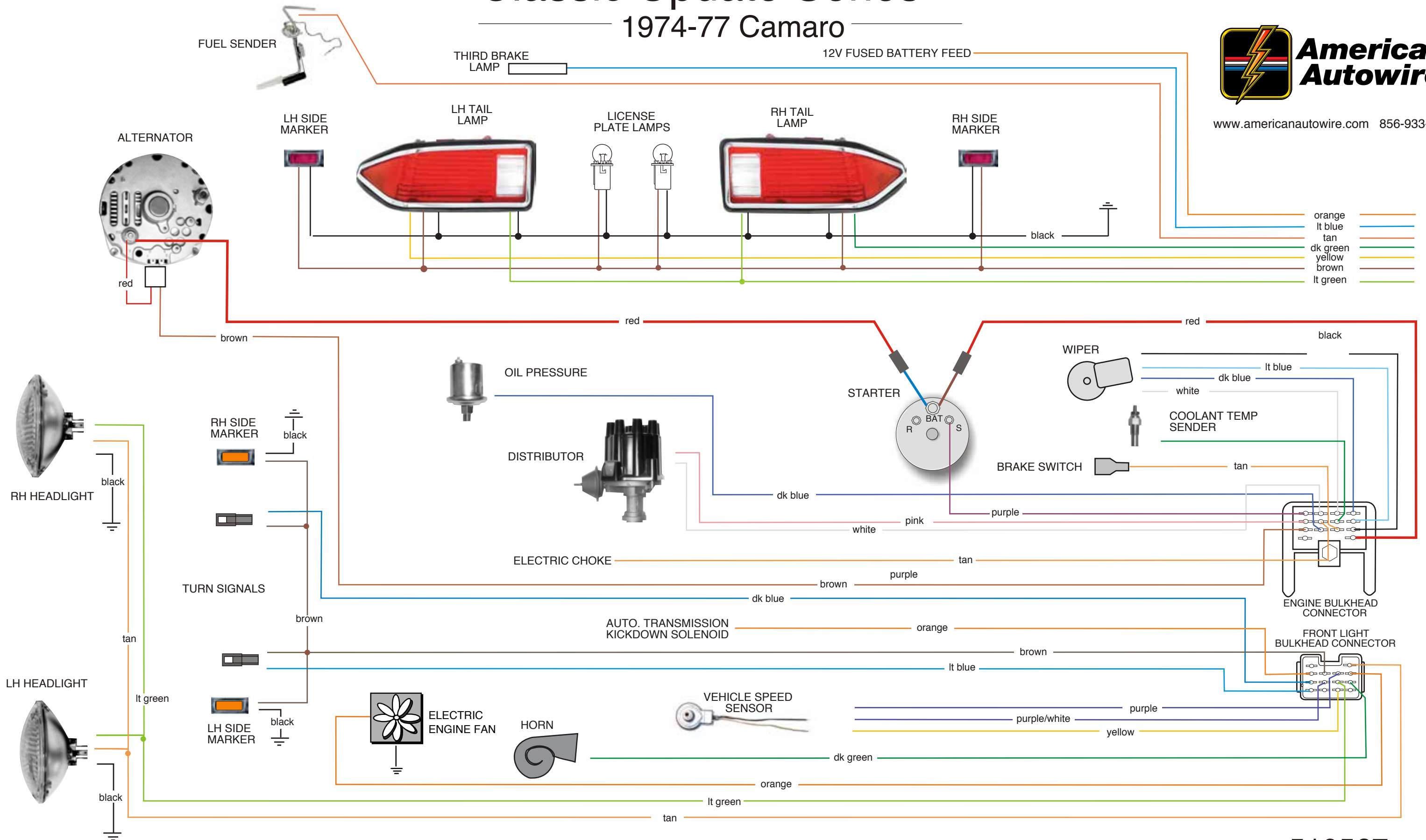

NOTICE: This schematic drawing is for reference only. Do not use the schematic to install this wiring kit! Use the instruction sheets included in each bag, which includes directions for proper terminations, and specific applications (such as Rally Sport).

510567

© COPYRIGHT 2004 American Autowire / Factory-Fit  
Used with express permission of American Autowire / Factory-Fit  
92970767 instruction sheet rev. 0.0 8/19/2014

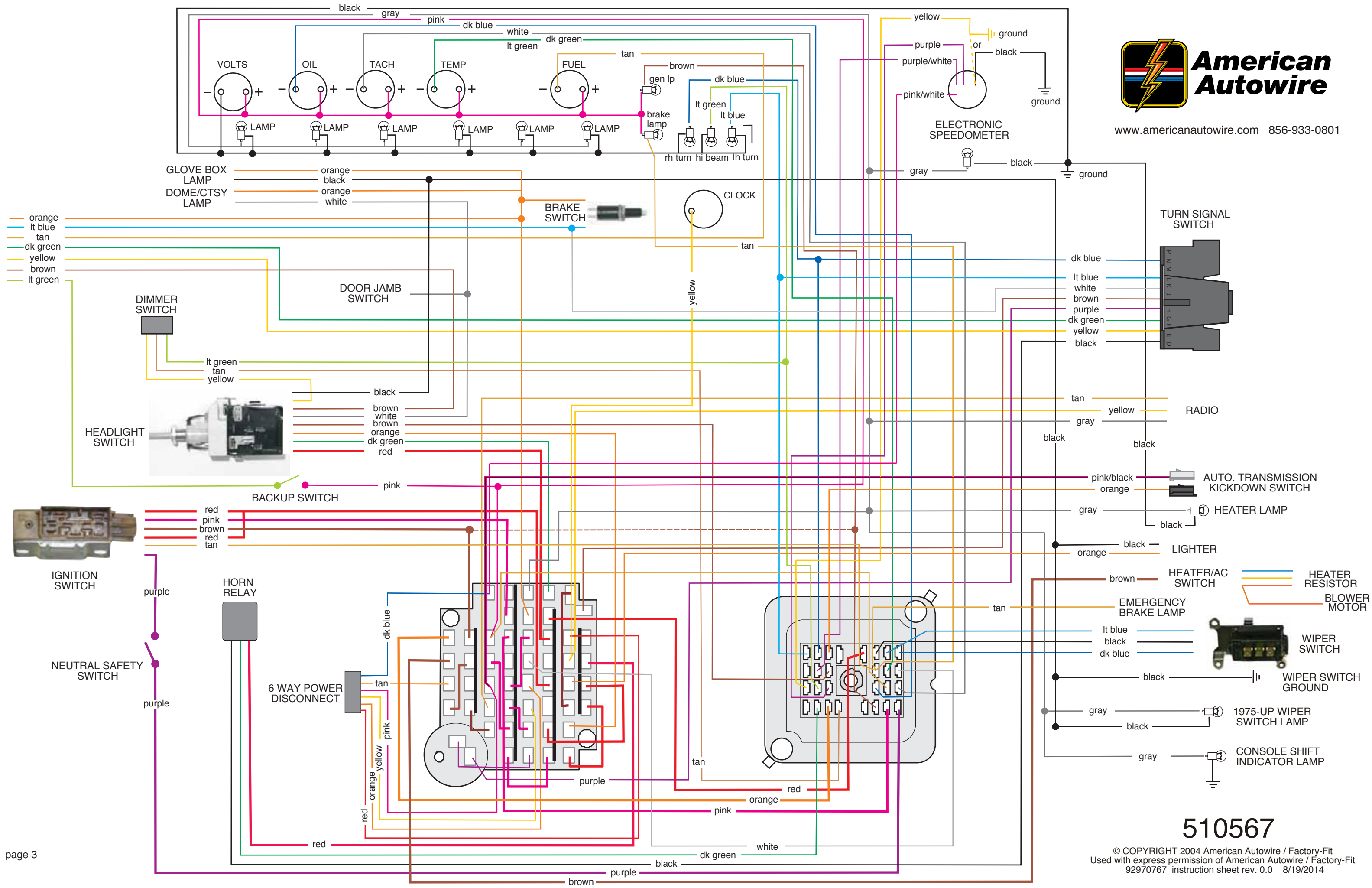

- orange
- lt blue
- tan
- dk green
- yellow
- brown
- lt green

- GLOVE BOX LAMP — orange
- DOME/CTSY LAMP — black
- orange
- white

- HEADLIGHT SWITCH — black
- brown
- white
- brown
- orange
- dk green
- red

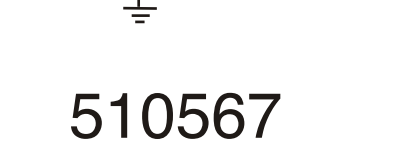
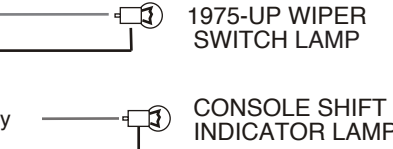
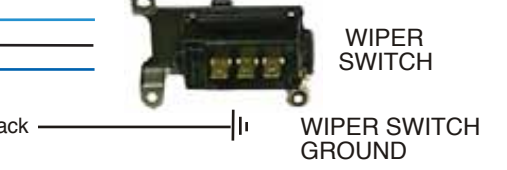
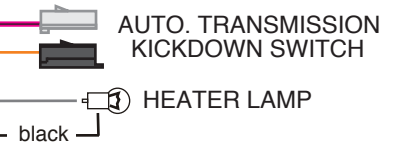
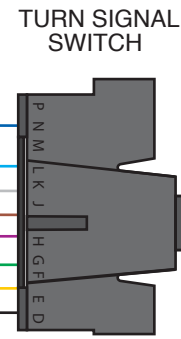

**510567**

THIS PAGE HAS BEEN INTENTIONALLY LEFT BLANK

