



INSTALLATION INSTRUCTIONS

MSD GM HEI Coil PN 8225

Parts Included:

1 - MSD Coil, PN 8225
1 - 4" Black Ground Wire
1 - Rubber Isolator

1 - Rotor Bushing
4 - Mounting Screws

The MSD HEI Coil is designed for use with the MSD High Output HEI Module, PN 8364. It will work with stock ignition modules but for maximum output use the MSD HEI Module.

Note: The Rotor Bushing supplied is a replacement unit designed for stock or mild HEI Distributors and has very high resistance. If an MSD 7 Series or Digital Series Ignition is used an MSD Low Resistance Rotor Bushing, PN 8412, must be used to prevent damage to the cap and rotor.

Disassembly

1. Remove the dust cover to access the HEI Coil and disconnect the three wiring harnesses from the distributor cap.
2. Remove the four screws that hold the original coil.
3. Lift the coil out of the cap and discard the original rubber isolator and rotor bushing.

Installation

1. Install the new rotor bushing and rubber isolator.
2. Install the MSD Coil. The terminals should slide easily into position into the cap. The Yellow and Red leads go in the outer slots of the cap. They cannot be interchanged.
3. Insert the Black ground wire in the center slot of the cap and connect it to one of the Coil's retaining screws (Figure 2).
4. Install the other three retaining screws followed by the dust cover and connect the harnesses.

MSD also offers the following parts to upgrade and maintain your GM HEI Distributor:

PN 8411	Heavy Duty Cap, Red
PN 8410	Rotor
PN 8402	Factory Style Dust Cover
PN 8412	Low Resistance Rotor Bushing
PN 8364	High Output Ignition Module
PN 8401	Modified Dust Cover for External Coil

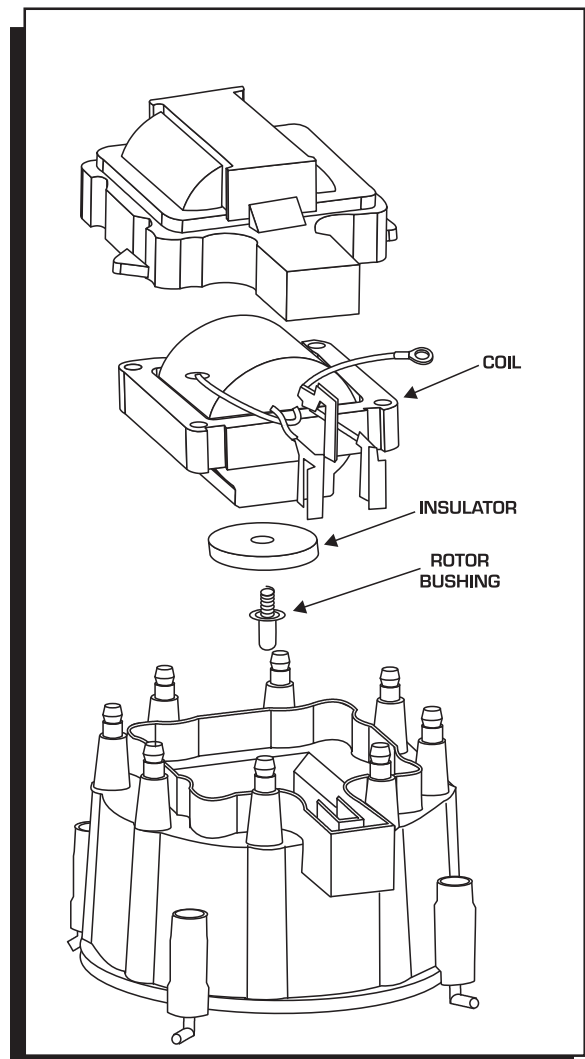

Figure 1 Installing the MSD GM HEI Coil.

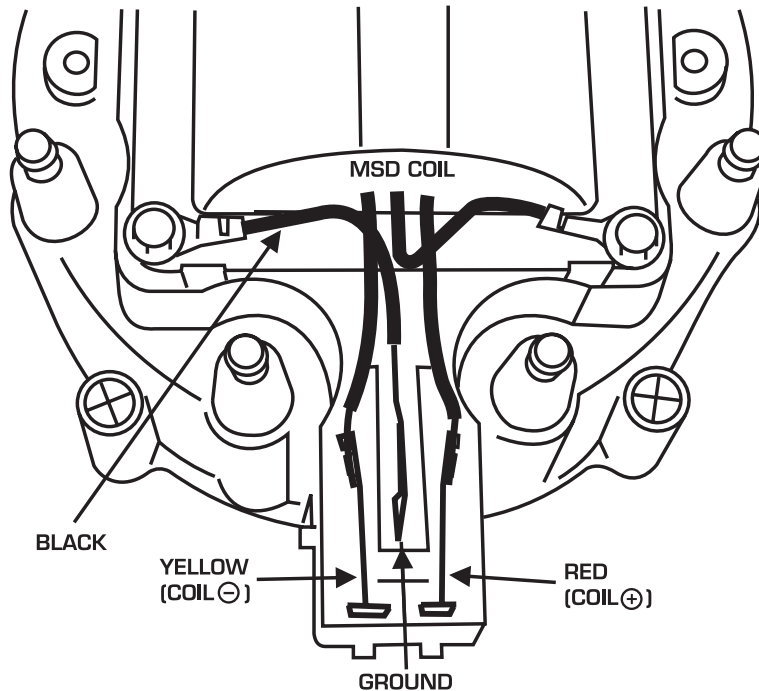

Figure 2 Wire Location.

Service

In case of malfunction, this MSD component will be repaired free of charge according to the terms of the warranty. When returning MSD components for service, Proof of Purchase must be supplied for warranty verification. After the warranty period has expired, repair service is charged based on a minimum and maximum charge.

Send the unit prepaid with proof of purchase to the attention of: **Customer Service Department, Autotronic Controls Corporation, 12120 Esther Lama, Suite 114, El Paso, Texas 79936.**

When returning the unit for repair, leave all wires at the length in which you have them installed. Be sure to include a detailed account of any problems experienced, and what components and accessories are installed on the vehicle.

The repaired unit will be returned as soon as possible after receipt, COD for any charges. (Ground shipping is covered by warranty). All units are returned regular UPS unless otherwise noted. For more information, call the MSD Customer Service Line (915) 855-7123. MSD technicians are available from 8:00 a.m. to 5:00 p.m. Monday - Friday (Mountain Time).

Limited Warranty

Autotronic Controls Corporation warrants MSD Ignition products to be free from defects in material and workmanship under normal use and if properly installed for a period of one year from date of purchase. If found to be defective as mentioned above, it will be replaced or repaired if returned prepaid along with proof of date of purchase. This shall constitute the sole remedy of the purchaser and the sole liability of Autotronic Controls Corporation. To the extent permitted by law, the foregoing is exclusive and in lieu of all other warranties or representations whether expressed or implied, including any implied warranty of merchantability or fitness. In no event shall Autotronic Controls Corporation be liable for special or consequential damages.