

**MSD to GM HEI Distributor Harness
PN 8875**

IMPORTANT: Review the installation procedures of the MSD 6 Series Ignition prior to connecting the wiring harness.

This Harness is designed to simplify the installation of an MSD 6 Series Ignition Control to a GM HEI Distributor that uses a 5-pin or 7-pin module (Figure 1). Most of these distributors **DO NOT** have a vacuum advance.

Note: On HEI distributors with a 4-pin module, this Harness cannot be used.

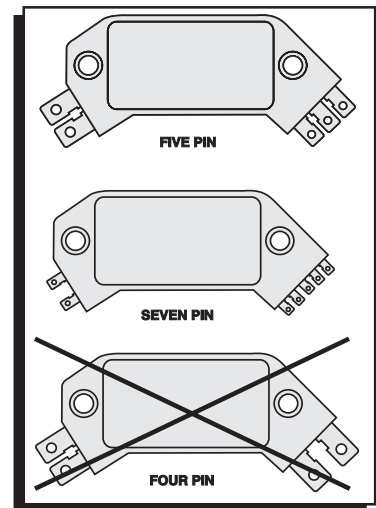

Figure 1 Different HEI Modules.

1. Disconnect the 12 volt key connector, the 3-wire connector coming out of the distributor and the Tach Connector (if applicable).
2. Connect the Pink, Black and one of the Brown wires of the Harness to the corresponding wires of the 3-wire connector coming out of the distributor.
3. Connect the Red wire of the Harness to the key connector.
4. Plug the 3-wire connector of the Harness into the distributor cap.
5. Connect the Orange, Black, Red and White wires of the Harness to the corresponding wires of the MSD Ignition Control.
6. If there was a tach wire going to into the distributor cap, connect it to the other brown wire of the MSD harness. If a tach is not being used, tape and seal this connector.

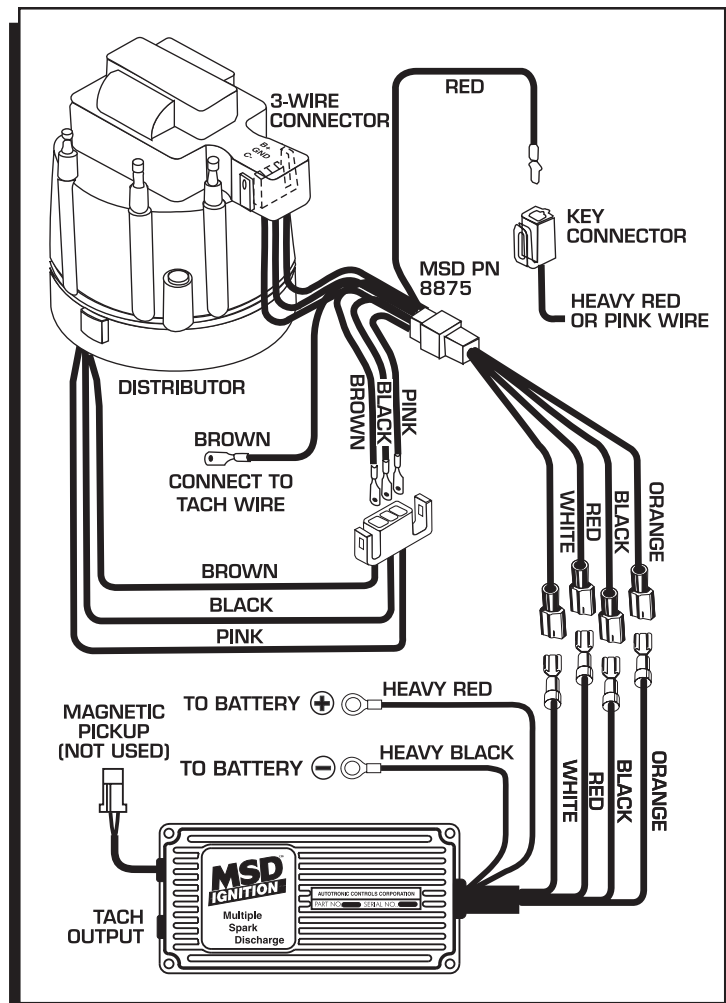

Figure 2 Wiring the PN 8875 Harness

In some rare applications with a 5-Pin HEI Ignition Module, the engine may run erratically or shut off on deceleration after the MSD Ignition is installed. To correct this, a diode assembly is available from MSD Customer Support. The diode assembly installs on the input end of the module on the middle terminal (Figure 3). Be sure the supplied lock washers are installed under the tab of the diode assembly.

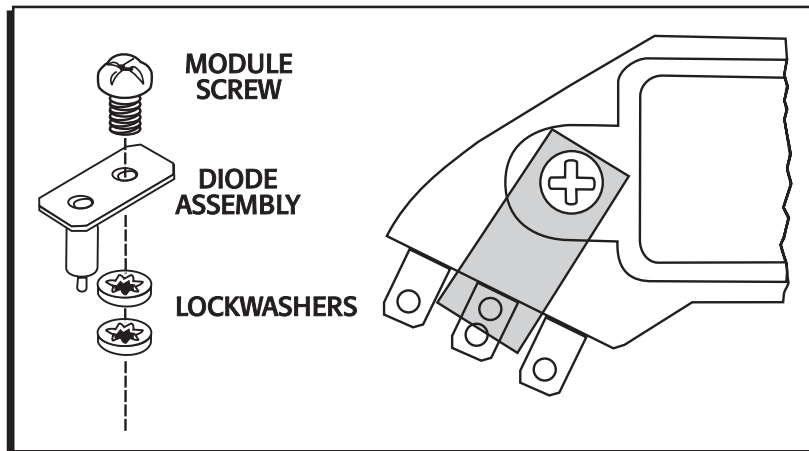

Figure 3 Installing the Diode Assembly with a 5-Pin Module.

Service

In case of malfunction, this MSD component will be repaired free of charge according to the terms of the warranty. When returning MSD components for service, Proof of Purchase must be supplied for warranty verification. After the warranty period has expired, repair service is charged based on a minimum and maximum charge.

Send the unit prepaid with proof of purchase to the attention of: **Customer Service Department, Autotronic Controls Corporation, 12120 Esther Lama, Suite 114, El Paso, Texas 79936.**

When returning the unit for repair, leave all wires at the length in which you have them installed. Cutting wires close to the unit will void your warranty. Be sure to include a detailed account of any problems experienced, and what components and accessories are installed on the vehicle.

The repaired unit will be returned as soon as possible after receipt, COD for any charges. For more information, call the MSD Customer Service Line (915) 855-7123. MSD technicians are available from 8:00 a.m. to 5:00 p.m. Monday - Friday (mountain time).

Limited Warranty

Autotronic Controls Corporation warrants MSD Ignition products to be free from defects in material and workmanship under normal use and if properly installed for a period of one year from date of purchase. If found to be defective as mentioned above, it will be replaced or repaired if returned prepaid along with proof of date of purchase. This shall constitute the sole remedy of the purchaser and the sole liability of Autotronic Controls Corporation. To the extent permitted by law, the foregoing is exclusive and in lieu of all other warranties or representations whether expressed or implied, including any implied warranty of merchantability or fitness. In no event shall Autotronic Controls Corporation be liable for special or consequential damages.